



BASIN OIL NL

VIC/RL5

Gippsland Basin, Bass Strait

AUSTRALIA

BALEEN 2

**Well Completion Report
Basic Data**

Volume 2

Drilling



Well Completion Report Volume 2

VIC/RL5 – Baleen-2

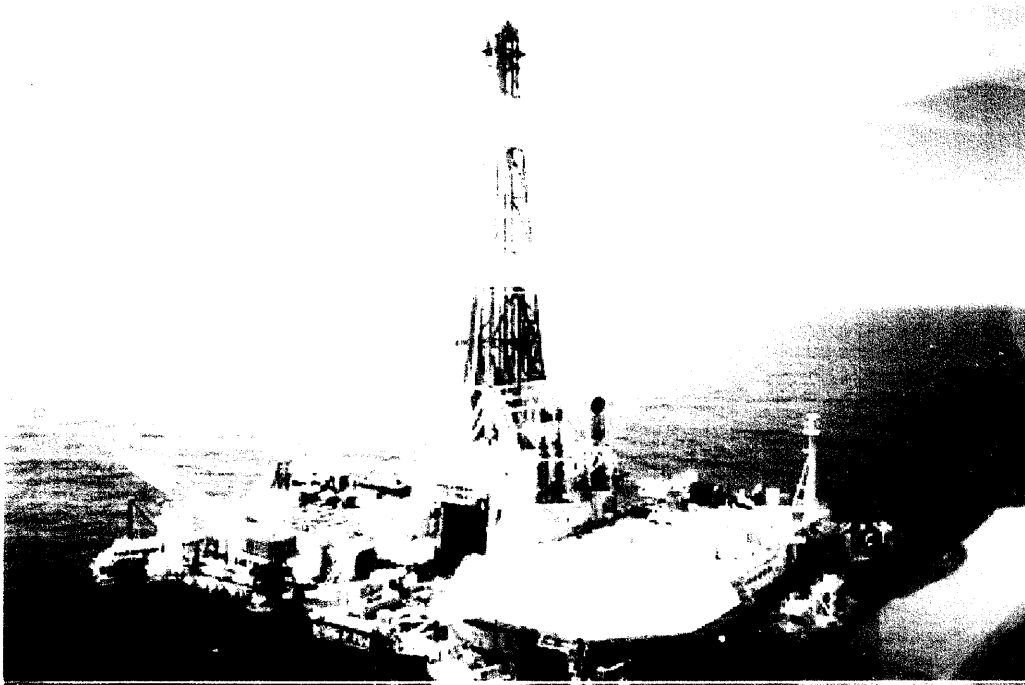

Cultus Drilling Manager	:	C. Way
Cultus Drilling Superintendent	:	G. Nicholl
Cultus Drilling Supervisor(s)	:	R. Kohut
Cultus Drilling Engineer(s)	:	W. Boon von Ochssee
Cultus Geologist	:	M. Adamson
Reviewed By	:	C. Way
Author	:	W. Boon von Ochssee
Date	:	6 January 2000

COPY NO. 4

CULTUS PETROLEUM NL

VIC/RL5 – BALEEN 2 – WELL COMPLETION REPORT VOLUME 2

TABLE OF CONTENTS

1. SUMMARY

- 1.1 General Data
- 1.2 Location Maps
- 1.3 Drilling Summary
- 1.4 Well Schematic
- 1.5 Geological Summary
- 1.6 Cost Summary
- 1.7 Days Vs Depth
- 1.8 Logistics

2. TIME BREAKDOWNS

- 2.1 Total Times
- 2.2 Time Analysis
- 2.3 Activity Reports
- 2.4 NPT Analysis
- 2.5 Industry Benchmarking

3. DRILLING DATA

- 3.1 Rig Specification
- 3.2 Casing & Cement
- 3.3 Bit & Hydraulics
- 3.4 Drilling Fluids
- 3.5 Cementing Recap
- 3.6 BHA Summary
- 3.7 Lessons Learnt

4. MARINE DATA

- 4.1 Rig Positioning

5. DAILY DRILLING REPORTS

6. SAFETY AND INCIDENTS

DISTRIBUTION LIST

**BASIN OIL NL
VIC/RL5 – BALEEN 2
BASS STRAIT
AUSTRALIA**

**WELL COMPLETION REPORT
BASIC DATA
VOLUME 2
DRILLING**

Original - Drilling Department (*Copy No. 1*)

Library (*Copies No. 2 & 3*)

Attention: Mr A Nadji (*Copies No. 4 & 5*)

Department of Natural Resources and
Environment
Petroleum Operations Branch
8 Nicholson Street
EAST MELBOURNE VIC 3002

Attention: Ms V Hill (*Copy No. 6*)

Department of Industry Science and Resources
20 Allara Street
CIVIC ACT 2600

Spare: (*Copy No. 7*)

908058 005

908058 006

1.1. General Data

Well Name: Baleen-2
Permit: VIC/RL5
Seismic Line: GL88-62, coincident with intersecting line GL88-55
Location: Lat 38° 01' 55.76" S
 Long 148° 24' 37.55" E
 Easting 623,781.4m
 Northing 5,789,663.9m
 UTM Zone 55 / ANS AGD 66 / CM 147°E
Block Equity: Basin Oil NL
 Level 4, 828 Pacific Highway
 Gordon, NSW 2072
Permit: VIC RL-5
Type of Well: Appraisal
Spud Date: 11 October 1999
Well Duration: 10 Days
Total Depth : 895m RT
Water Depth: 54.8m MSL
RTE: 24.9m
RT to Seafloor: 80.7m
Rig : Sedco 702
Drilling Contractor: Sedco Forex
Well Objectives :
 - Primary objective: Gurnard Formation
 - Secondary objective: Sandstones within the Latrobe Group

903058 008



CULTUS PETROLEUM N.L.
GIPPSLAND BASIN - OFFSHORE VICTORIA
TENEMENT ACTIVITY MAP
 August, 1999

Cultus Tenement

Gas Pipeline
Oil Pipeline

0 km 30

PROPOSED GAS PIPELINE

Victoria

■ Orbost

■ Lakes Entrance

VICPTIV

VICRLIV

VICRL5

PATRICIA/BALEEN GAS FIELD

Sale

Longford

WEST SEAHORSE

SEAHORSE

GOLDEN BEACH

BARRACOUTA

SWEETLIPS

SNAPPER

MARLIN

TUNA OIL FIELD

FLOUNDER

FORTESCUE HALIBUT

BREAM

MACKEREL

KINGFISH

DOLPHIN

PERCH

BASS

STRAIT

VIC/RL5

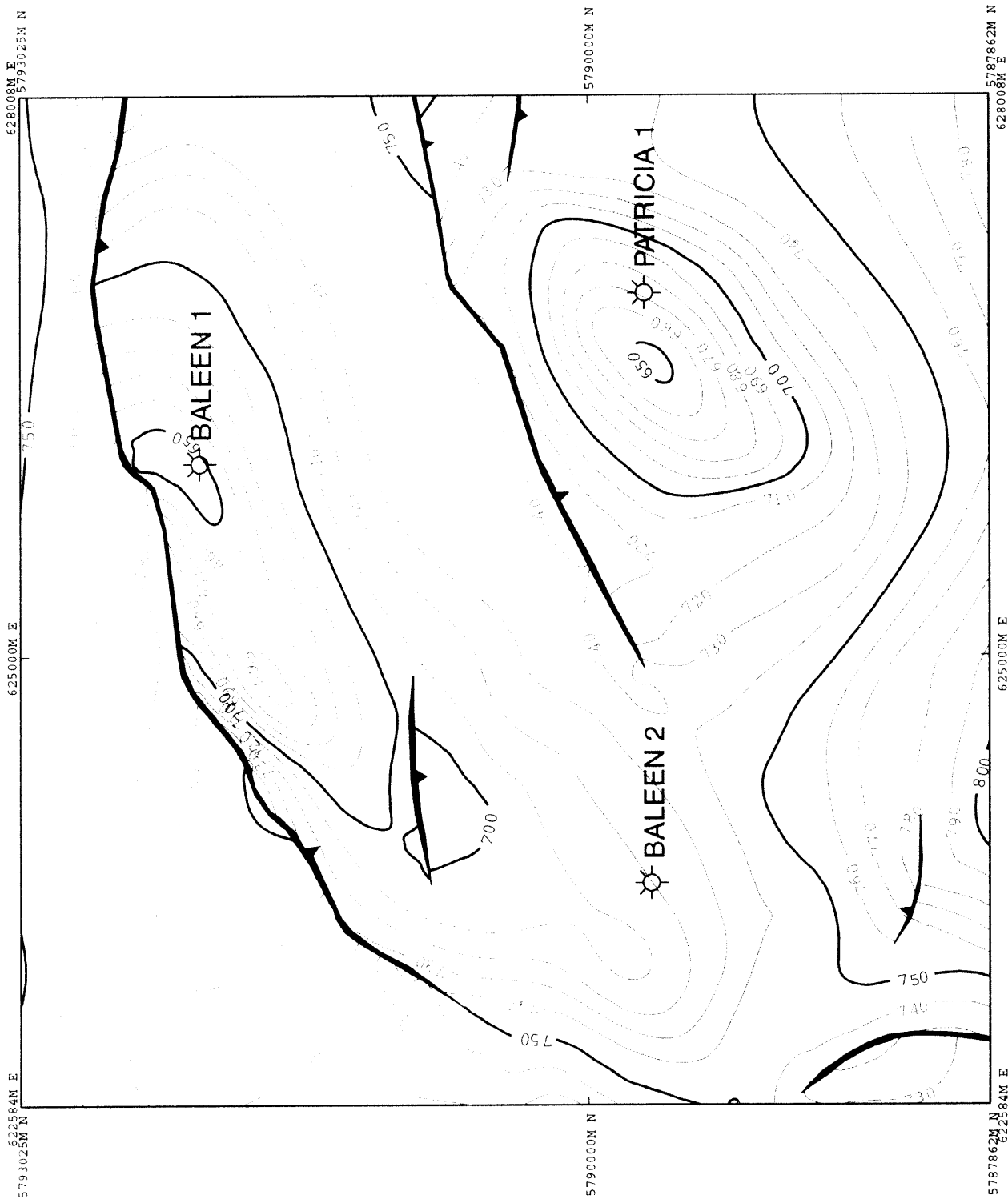

CULTUS PETROLEUM N.L.

Gippsland Basin
VIC/RL5
 Depth Structure Map
 Top Churned/Purported

908058 011

1.3 Drilling Summary

1.3.1 Times & Dates

Contract Rig	02:30 hrs	7 Oct 1999
Arrive on Location	12:00 hrs	10 Oct 1999
Spud Well	02:15 hrs	11 Oct 1999
Run & Cement 30"	13:45 hrs	11 Oct 1999
Drill 12 1/4" to 650mRT	15:00 hrs	12 Oct 1999
Run & Cement 9 5/8"	06:30 hrs	13 Oct 1999
Run & Test BOPE	06:30 hrs	13 Oct 1999
Drill out Shoe Track	02:00 hrs	14 Oct 1999
Perform FIT	09:15 hrs	14 Oct 1999
Drill to Coring Point	10:45 hrs	14 Oct 1999
Core Gurnard Formation	02:25 hrs	15 Oct 1999
Drill to TD	02:45 hrs	16 Oct 1999
Ran openhole logs	17:00 hrs	16 Oct 1999
Plug and Abandon	02:45 hrs	18 Oct 1999
Release rig		

1.3.2 Hole Sizes & Casing Depth

1.3.3 Status

Baleen 2 was drilled to a total depth of 895mRT. Two cement plugs were placed across the reservoir sand with the TOC of plug #2 tagged at 580mRT, 70m above the 9 5/8" casing shoe. The hole was displaced to inhibited water based mud prior to setting a bridge plug at 180m and placing a 50m cement plug on top. The wellhead, housing and PGB were retrieved with the casing and conductor cut 5m below the seabed.

1.3.4 Operations Summary

During the final stages of the Globex program bulk, mud & cement chemicals and equipment were loaded out from the Port of Geelong. The Sedco 702 was taken on contract at 02:30 hours, 7 October 1999 when the final anchor was pulled at the end of the Barramundi 1 well.

The Pacific Challenger and Pacific Shogun towed the rig to the VIC-RL5 Baleen 2 location. The rig was positioned and the final location calculated by Differential GPS. The final rig position was 1.08m on a bearing of 326°T (326.9°G) from the intended location.

After approval of the final rig position Baleen 2 was spudded at 02:15 hrs, 11 October 1999. The 36" x 26" hole section was drilled to 125.7mRT (RT to mudline 80.7m with a water depth of 54.8m). Ran and cemented 30" wellhead housing, 30" conductor and 30" x 20" shoe joint. Drilled out 20" shoe with 17 1/2" bit.

Drilled 12 1/4" hole section riserless to 650mRT. Survey every 100m using the Anderdrift vertical inclination indicator. Dropped magnetic single shot at TD. Circulated and performed wiper trip prior to circulating to spud mud prior to POOH.

Ran 9 5/8" casing with 18 3/4" SS-10C wellhead. Cement plugs did not bump, however final back pressure indicated good cement placement.

Ran BOP, LMRP and marine riser. Function and pressure tested BOPE. Top of cement tagged 26m above float collar. Drilled out shoe track and new formation. Displace well to 10.1ppg NaCl/PHPA mud. Performed 15 ppg (1.80 sg) FIT at 654mRT.

The 8 1/2" hole section was drilled with controlled parameters to coring point at 746mRT. Two 18m cores were cut across the Gurnard formation with a respective 100% and 88% recovery.

A locked 8 1/2" BHA was run to drill the 8 1/2" section to planned TD at 895mRT, approx. 50m into the Strzelecki.

The final logging suit consisted of PEX/HALS/DSI/NGS, FMI/GR, MDT/GR and CSAT/GR(VSAP).

For the Baleen abandonment two cement plugs were placed across the reservoir sand with the TOC of plug #2 tagged at 580mRT, 70m above the 9 5/8" casing shoe. A bridge plug was set at 180m with a 50m cement plug placed on top. The wellhead, housing and PGB were retrieved with the casing and conductor cut 5m below the seabed.

1.3.5 Surveys

In the 36" x 16" hole a magnetic single shot survey was run at section TD. An Andergauge vertical inclinometer was incorporated in the 12 1/4 BHA to take surveys every 100m whilst drilling. In addition magnetic single shot survey was run at section TD.

No directional survey were run whilst drilling the 8 1/2" hole section. A survey module was included in the wireline logging toolstring. GPIT (FMI toolstring)

Depth (mRT)	Inclination	Tool
126	0.75	Hofco Magnetic SS
252	≤ 0.5	Anderdrift
310	≤ 0.5	Anderdrift
397	≤ 0.5	Anderdrift
513	≤ 0.5	Anderdrift
597	≤ 0.5	Anderdrift
650	0.25	Hofco Magnetic SS
750	0.2	GPIT
850	0.7	GPIT



Baleen 2 Abandonment Schematic

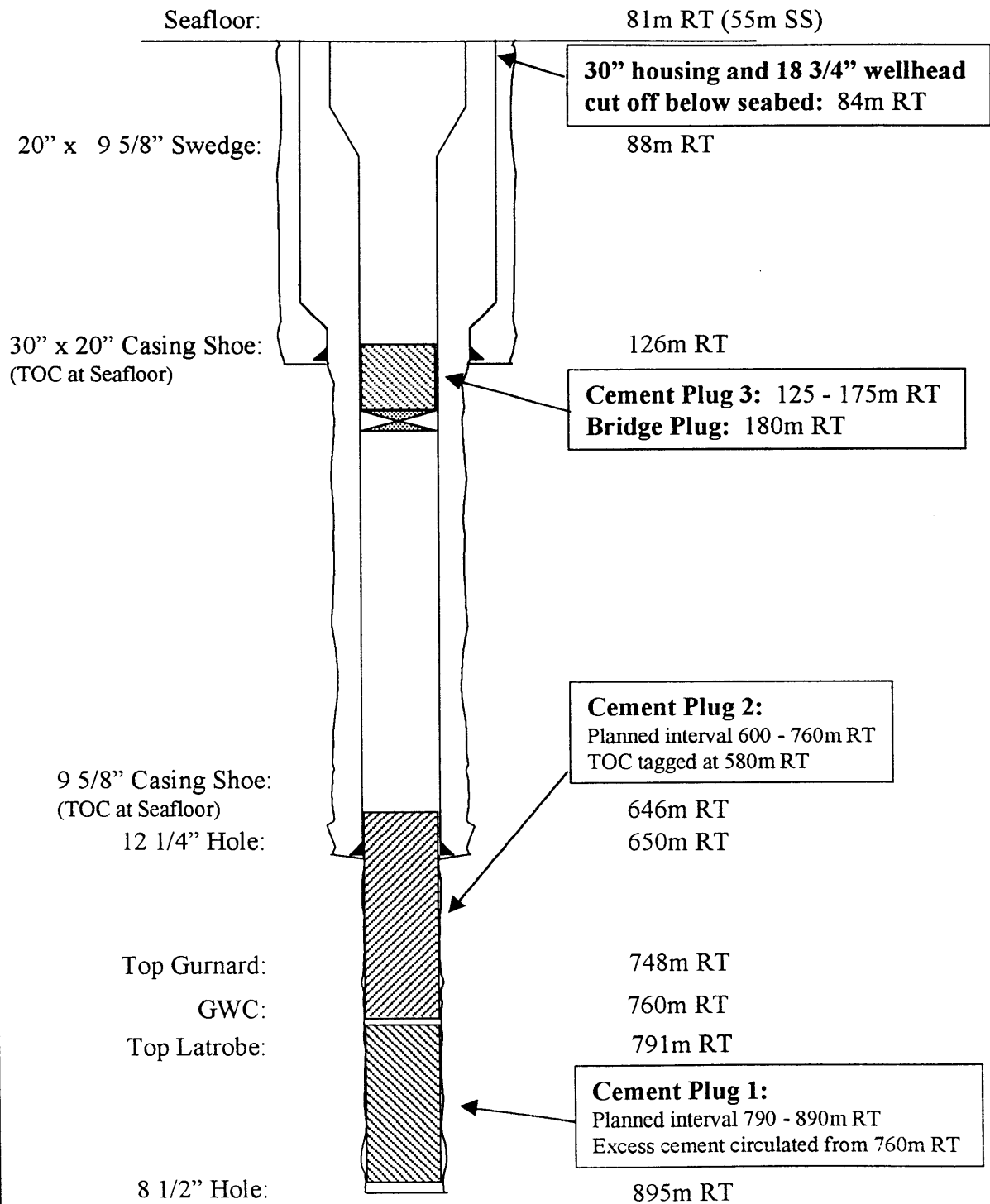

1.5 Geological Summary

Baleen-2 was an appraisal well drilled in the northern Gippsland Basin on the southwest extension of the Baleen portion of the Patricia-Baleen Gas Field. The well was drilled 3.31 km southwest and structurally downdip of the Baleen-1 discovery well which had dry gas accumulations in the Gurnard Formation and Latrobe Group Coarse Clastics.

The Patricia-Baleen Gasfield was mapped using several vintages of reprocessed data from 1979-1992. Good horizon continuity and a direct hydrocarbon indicator are observed at the discovery location and extend to Baleen-2. The pre-drill inferred GWC at 734mSS, the observed DHI and 'flat lying event' gave the interpretation a high degree of confidence that at least 7m of gas column would be intersected. The depth conversion, based on a depth of burial average velocity trend, proved very accurate (just over 1.3% error) and 16.2m of gross gas column were intersected in the well.

The stratigraphy was very similar to prediction with some 31m loss in thickness of the Lakes Entrance Fm and 41m gain in Gippsland Limestone thickness. The objective Gurnard Fm was intersected 10m low to prognosis at 720mSS (746mRT) and had the predicted 45m gross thickness. The well was drilled to a total depth of 869mSS, (895mRT) some 18m into the Strzelecki Group, the local economic basement.

Two cores were cut in the Gurnard Fm from 720mSS to 754.3mSS straddling the GWC with 93.7% recovery. Oil shows were noted in the lower part of core #1 over the interval 730mSS to 738mSS where moderately bright yellow green patchy fluorescence with blooming cut fluorescence is noted from the poorer quality reservoir. Similar shows were reported in the Sperm Whale-1 well and it appears that an earlier oil charge to the structure has been displaced by gas.

The deepest gas in Baleen-1 was at 683.5mSS and 703.0mSS in the Gurnard Fm and Latrobe Group respectively. Both these accumulations had 'gas on rock' LKG levels and a much deeper GWC had been estimated from wireline formation pressure data (734mSS). The main objective for the Baleen-2 well was to intersect a GWC in the Gurnard Fm and test the reservoir extent, continuity and quality. All these objectives were met. A further objective of recovering gas samples from the Gurnard Fm was not achieved through a combination of the low permeability, friable reservoir and operational limitations of the wireline sampling tool used. No hydrocarbons were found in the Latrobe Group.

Petrophysical analysis of the logs and pressure data confirm a dry gas column in the upper part of the Gurnard Fm from 721.8mSS to 738.0mSS, a water wet lower Gurnard Fm and Latrobe Group sandstones. Average porosity of the gross gas column is 29.5% with associated average gas saturations of 36%. The low gas saturation appears to be a function of the very fine grained, clay rich rock in close proximity to the GWC and is therefore expected. Core and recovered fluid studies are ongoing and will further refine the reservoir model.

Wireline pressure data also demonstrated a regional drop in aquifer pressure of the Latrobe Group and consequent drop in Gurnard Fm reservoir pressure in the last 18 years. Since 1981 when the Baleen-1 well was drilled until this well Baleen-2 in 1999, the pressure in the Gurnard Fm gas reservoir has fallen from 1107psia to 1071 psia.

The primary objective Gurnard Formation is a shallow marine, transgressive greensand unit with a high proportion of silt and clays. The complex mineralogy adversely affects the petrophysical analysis with mica, glauconite, siderite and pyrite present. Overall, reservoir quality is slightly better at the Baleen-2 location compared to the Patricia-1 and Baleen-1 wells. There are less of the siderite cemented bands and therefore a higher net reservoir to gross formation ratio of 78.7% versus 64% and net effective porosities are slightly better at 29% versus 27%.

The well was plugged and abandoned on 18 October 1999.

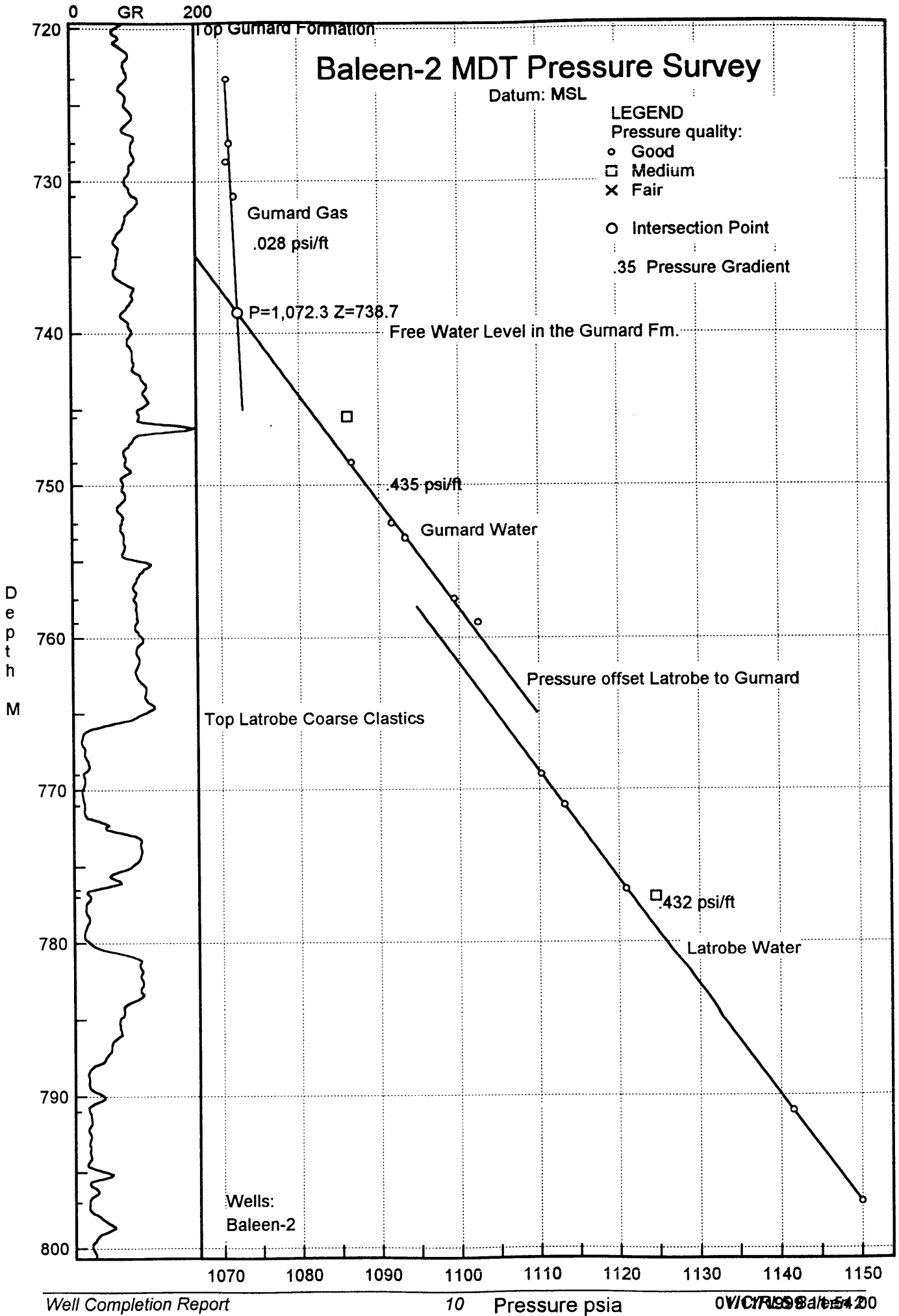

Patricia / Baleen RFT data

908058 020

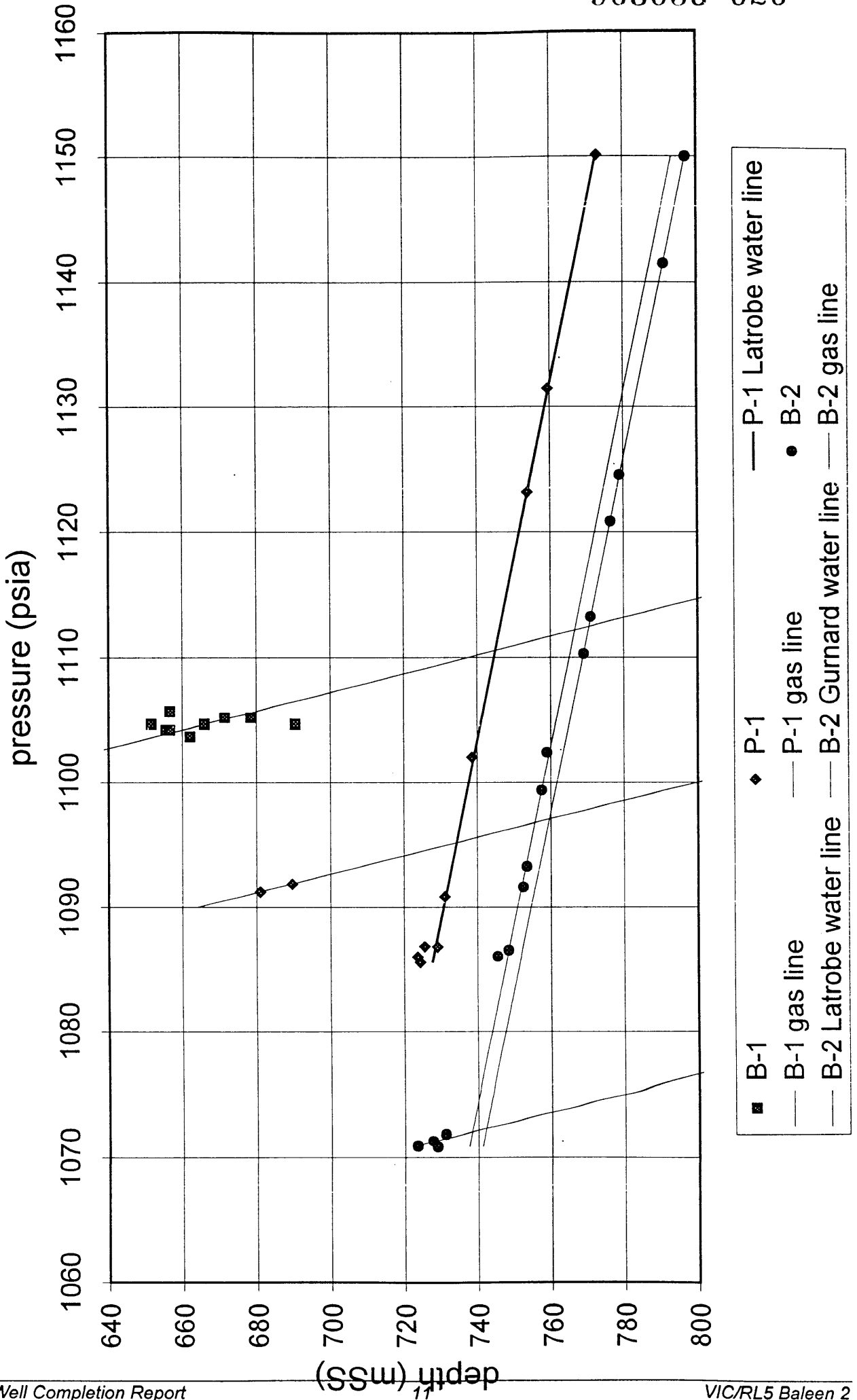



CULTUS

Predicted Section

BALEEN-2

Actual Section

LOCATION: GL88-62
SP 366

LATITUDE: 38°01'55.79"S
LONGITUDE: 148°24'37.57"E

EASTING: 623782
NORTHING: 5789663

WATER DEPTH: 55m
RT: 26m AMSL

DEPTH (metres)	AGE		STRATIGRAPHIC UNIT		TWT (sec)	DEPTH (metres) mRT	LITHOLOGY	TWT (sec)	DEPTH (metres) mRT	LITHOLOGY	OBJ	DESCRIPTION	CASING			
	SYSTEM	SERIES	GROUP	FORMATION												
				SEA FLOOR	71	53 75		71	55 81							
100	TERTIARY	MIOCENE	SEASPRAY GROUP	GIPPSLAND Limestone								Calcarenites, Limestones, Marls, Calcilutites	20730 @ 120mRT			
200																
300																
400																
500	Eocene	LATIOBE GROUP	SEASPRAY GROUP	LAKES ENTRANCE FORMATION								Calcareous Claystones occasional Marls				
600																
700																
800																
900	EARLY CRETACEOUS	EOCENE	LATIOBE GROUP	IBARRACOUTA FORMATION								Calcareous Claystones, occ. Marls & trace Glau				
				COARSE CLASTICS								Silty Sandstones, mica glauc. v. argill. f-gd. porosity, minor shows				
				STRZELECKI GROUP								Medium grained Sandstone minor clayst. inter beds v. good porosity				
												Clayst. w Sandy Clayst. inter beds				
												TOTAL DEPTH 895mRT				
1000												TOTAL DEPTH 895mRT				

903058 022

WELL AFE - COST TRACKING

Well: Patricia - Baleen Rig on Hire: 10/7/99
 Area: VIC RL-5 Spud Date: 10/11/99
 Permit: VERTICAL APPRAISAL WELL Rig Release: 10/19/99
 Country: Australia
 AFE No: 99-RL5-01

	Cost Tracking	AFE	Difference
SITE SURVEY AND POSITIONING		\$30,000	-\$22,060
EQUIPMENT TRANSPORT AND MOB/DEMOR		transferred to vessel & rig	\$0
4 days mob vs 1.5 days in AFE (Vessel & Rig Only)	\$561,831	\$185,712	-\$375,919
TRAVEL AND ACCOMMODATION	\$159,500	\$33,450	\$23,050
HELICOPTERS	\$107,289	\$44,550	\$62,748
SUPPLY VESSELS	\$189,200	\$344,100	\$151,200
4 days mobilisation vs 1.5 days if AFE with lower rates	\$152,400	\$32,250	\$120,150
Vessels at higher rates	\$342,900	\$311,850	\$31,050
WHARFAGE AND STEVEDORING	\$30,000	\$66,963	-\$36,963
METEOROLOGICAL/OCEANOGRAPHIC	\$3,834	\$3,160	-\$1,628
DIVING	\$53,769	\$57,915	-\$4,146
CONTRACT RIG	\$1,815,244	\$1,835,000	\$118,848
4 days mob vs 1.5 days in AFE (Rig Only)	\$369,140	\$153,461	\$215,679
Rig cost	\$969,321	\$1,066,154	-\$96,833
Demob fee	\$615,385	\$615,385	\$0
CONTRACT CATERING	\$12,000	\$9,900	\$3,100
MUD ENGINEERING AND MATERIALS	\$33,764	\$58,426	\$24,728
CEMENTING SERVICES AND EQUIPMENT	\$96,337	\$107,641	-\$13,309
WELL TESTING	\$0	\$0	\$0
CORING	\$67,816	\$105,110	-\$43,295
MUD LOGGING	\$30,076	\$36,575	-\$6,500
DIRECTIONAL DRILLING	\$10,208	\$31,850	-\$12,552
ELECTRIC WIRELINE LOGGING	\$178,922	\$199,910	-\$20,988
CASING, LINER AND ACCESSORIES	\$121,912	\$157,287	-\$35,375
COMPLETION EQUIPMENT	\$0	\$0	\$0
COMMUNICATIONS	\$7,345	\$0	\$7,345
DRILLING BITS	\$64,940	\$100,000	-\$35,060
DOWNHOLE TOOL RENTAL	\$55,662	\$89,654	-\$33,992
WELLHEAD & SS TREE	\$142,560	\$82,905	\$59,645
CONSULTANTS	\$162,880	\$317,772	-\$154,912
TIME WRITING	\$82,500	\$137,250	-\$84,750
FUEL AND LUBES	\$159,074	\$138,353	\$20,318
Fuel consumption during 4 day move	\$80,943	\$0	\$80,943
Fuel consumption for drilling operations	\$77,728	\$138,353	-\$60,625
INSURANCE, ACCOUNTING & LEGAL	\$0	\$0	\$0
ENVIRONMENTAL AND SAFETY	\$18,000	\$25,000	-\$9,000
ANALYTICAL SERVICES - NOT INCLUDED	\$0	\$0	\$0
DRAFTING AND CONSUMABLES	\$19,000	\$53,650	-\$34,650
OTHERS	\$3,900	\$2,730	\$1,170
TOTAL WELL COSTS	\$3,912,724	\$4,069,150	-\$77,027

WELL AFE

Well: Patricia - Baleen
 Area: Number of Well in Programme: 1
 Permit: VERTICAL APPRAISAL WELL
 Country: Australia
 AFE No:
 Dry Hole Days: 9.10 92 mtr/day
 Abandon Days: 9.90
 TVD, m RT: 830
 MD, m RT: 840 3690 \$/mtr
 Rig Move Days: 1.5 x 1.5 Based on Bass Strait Mobilization

Acc. Code									Total
850 SITE SURVEY AND POSITIONING									\$30,000
Site Survey (Seabed)	\$0	0	\$0	\$0	\$0	0	\$0	\$0	
Rig Positioning	\$30,000	0	\$0	\$30,000	\$0	0	\$0	\$0	
730 EQUIPMENT TRANSPORT AND DEMOBILIZATION									\$407,096
Mobilisation work boats	\$0	1.50	\$21,500	1	\$32,250	\$0	0	\$0	
Mobilisation rig	\$0	1.50	\$102,308	1	\$153,462	\$0	0	\$0	
Mobilisation services	\$0	0	\$0	1	\$0	\$0	0	\$0	
Demobilisation work boats	\$0	0	\$0	1	\$0	\$0	0.00	\$0	
Demobilisation rig	\$0	0	\$0	1	\$0	\$615,385	0.00	\$107,692	
Demobilisation services	\$0	0	\$0	1	\$0	\$0	0	\$0	
Land freight	\$0	0	\$0	1	\$0	\$0	0	\$0	
Courier	\$0	0	\$0	1	\$0	\$0	0	\$0	
878 TRAVEL AND ACCOMMODATION									\$3,450
Airfares	\$0	9.1	\$3,500		\$31,850	\$0	0.8	\$2,000	
Accommodation	\$0	0	\$0		\$0	\$0	0	\$0	
776 HELICOPTERS									\$3,600
Helicopters (Mob/Demob)	\$0	0	\$0		\$0	\$0	0	\$0	
Standing Charges: Helicopters	\$0	0	\$0		\$0	\$0	0	\$0	
Flying Rate: per flight / 2 hr flight.	\$0	0	\$0		\$0	\$0	0	\$0	
Base Charges	\$0	9.1	\$4,500		\$40,950	\$0	0.8	\$4,500	
865 SUPPLY VESSELS									\$19,600
Main Supply Vessel	\$0	9.10	\$19,500		\$177,450	\$0	0.8	\$19,500	
Standby Vessel	\$0	9.10	\$12,000		\$109,200	\$0	0.8	\$12,000	
905 WHARFAGE AND STEVEDORING									\$4,400
Warehouse, yard, etc.	\$0	11.375	\$5,500		\$62,563	\$0	0.8	\$5,500	
Office	\$0	0	\$0		\$0	\$0	0	\$0	
Stevedoring	\$0	0	\$0		\$0	\$0	0	\$0	
Duties Fee's and bonds	\$0	0	\$0		\$0	\$0	0	\$0	
Rental equipment (skips, etc)	\$0	0	\$0		\$0	\$0	0	\$0	
800 METEOROLOGICAL/OCEANOGRAPHIC									\$3,160
Weather forecast (rig move)	\$0	3	\$200		\$600	\$0	2	\$200	
Weather forecast (rig operations)	\$0	10	\$200		\$2,000	\$0	0.8	\$200	
735 DIVING									\$37,916
Mobilisation	\$0	0	\$0		\$0	\$0	0	\$0	
Demobilisation	\$0	0	\$0		\$0	\$0	0	\$0	
ROV, Control Cabin - Standby	\$0	9.1	\$1,750		\$15,925	\$0	0.8	\$1,750	
ROV, Control Cabin - Operating	\$0	0	\$0		\$0	\$0	0	\$0	
ROV, Control Cabin - Transit	\$0	0	\$0		\$0	\$0	0	\$0	
Senior pilot (or crew)	\$0	9.1	\$4,100		\$37,310	\$0	0.8	\$4,100	
Pilot Technician	\$0	0	\$0		\$0	\$0	0	\$0	
Pilot Technician	\$0	0	\$0		\$0	\$0	0	\$0	
Consumables	\$0	0	\$0		\$0	\$0	0	\$0	
750 CONTRACT RIG									\$1,066,154
Operating Rate	\$0	9.1	\$107,692		\$980,000	\$0	0.8	\$107,692	
Moving Rate	\$0	0	\$0		\$0	\$0	0	\$0	
Standby Rate	\$0	0	\$0		\$0	\$0	0	\$0	
Additional Costs	\$0	9.1	\$0		\$0	\$0	0.8	\$0	
765 CONTRACT CATERING									\$800
Excess meals / accomadation (10 people average per day @ 100 A\$/person)	\$0	9.1	\$1,000		\$9,100	\$0	0.8	\$1,000	
810 MUD ENGINEERING AND MATERIALS									\$58,426
Engineering services	\$0	9.1	\$1,030		\$850	\$0	0.8	\$850	
Mud Lab	\$0	10	\$45		\$450	\$0	0.8	\$45	
36" x 17-1/2" Hole Section	\$0	0	\$0		\$0	\$0	0	\$0	
26" Hole Section	\$7,500	0	\$0		\$7,500	\$0	0	\$0	
17-1/2" Hole Section	\$0	0	\$0		\$0	\$0	0	\$0	
12-1/4" Hole Section (100 A\$/m)	\$20,000	0	\$0		\$20,000	\$0	0	\$0	
8-1/2" Hole Section (200 A\$/m)	\$20,000	0	\$0		\$20,000	\$0	0	\$0	
Total Mud Cost (based on WBM only)	\$0	0	\$0		\$0	\$0	0	\$0	
Solids Control Equipment	\$0	9.1	\$900		\$8,190	\$0	0	\$0	
Completion Fluid	\$0	0	\$0		\$0	\$0	0	\$0	
Filtration Equipment	\$0	0	\$0		\$0	\$0	0.8	\$900	
710 CEMENTING SERVICES AND EQUIPMENT									\$107,541
Cementing Equipment package	\$0	9.1	\$1,580		\$14,378	\$0	0.8	\$1,580	
Cement Engineer	\$0	9.1	\$1,100		\$10,010	\$0	0.8	\$1,100	
Cement Helper	\$0	4.55	\$920		\$4,186	\$0	0	\$0	
30" Cement Job	\$0	0	\$0		\$0	\$0	0	\$0	
20" Cement Job	\$0	0	\$0		\$0	\$0	0	\$0	
13-3/8" Cement Job	\$0	0	\$0		\$0	\$0	0	\$0	
9-5/8" Cement Job	\$0	0	\$0		\$0	\$0	0	\$0	
7" Cement Job	\$0	0	\$0		\$0	\$0	0	\$0	
Well Cost	\$78,923	0	\$0		\$78,923	\$0	0	\$0	
Abandonment	\$0	0	\$0		\$0	\$0	0	\$0	
9-5/8" Cement Plugs (SSR)	\$0	0	\$0		\$0	\$0	0	\$0	

ACC Code									
890- WELL TESTING									
Surface & Downhole Equipment	\$0	0	\$8,231	\$0	\$0	0.8	\$8,231	0	\$0
Data Acquisition	\$0	0	\$2,385	\$0	\$0	0.8	\$2,385	0	\$0
Well Testing Crew	\$0	0	\$4,000	\$0	\$23,077	0.8	\$4,000	0	\$0
720 CORING									
Coring Equipment Rental	\$30,000	0	\$0	\$30,000	\$0	0	\$0		\$0
Coring Engineer	\$0	9.1	\$1,600	\$14,580	\$0	0	\$0		\$0
Core Bit (Per unit)	\$5,250	0	\$0	\$5,250	\$0	0	\$0		\$0
Coring Consumables	\$0	0	\$0	\$0	\$0	0	\$0		\$0
Core Analysis	\$55,300	0	\$0	\$55,300	\$0	0	\$0		\$0
810 MUD LOGGING									
Operating Day Rate	\$0	9.1	\$1,500	\$13,850	\$0	0.8	\$1,500		\$1,200
Standby Day Rate	\$0	0	\$0	\$0	\$0	0	\$0		\$0
Holding Day Rate	\$0	0	\$0	\$0	\$0	0	\$0		\$0
Data Engineer x 2	\$0	9.1	\$1,200	\$10,920	\$0	0	\$1,200		\$0
Mud Logger x 2	\$0	9.1	\$800	\$7,280	\$0	0	\$1,200		\$0
Miscellaneous Consumables	\$0	9.1	\$250	\$2,275	\$0	5	\$250		\$1,250
DIRECTIONAL DRILLING									
MWD Package	\$0	0	\$2,300	\$0	\$0	0.8	\$0		\$0
LWD Package	\$0	0	\$0	\$0	\$0	0	\$0		\$0
Directional Survey Package (w/ wireline unit)	\$12,000	0	\$0	\$0	\$0	0	\$0		\$0
Motor Package	\$0	9.1	\$2,700	\$24,570	\$0	0	\$0		\$0
MWD / LWD engineer	\$0	0	\$800	\$0	\$0	0	\$0		\$0
Directional Driller	\$0	9.1	\$800	\$7,280	\$0	0	\$0		\$0
Survey Crew	\$0	0	\$0	\$0	\$0	0	\$0		\$0
760 ELECTRIC WIRELINE									
Logging unit	\$0	9.1	\$1,500	\$13,850	\$0	0.8	\$1,500		\$1,200
Logging Crew - Standby	\$0	0	\$0	\$0	\$0	0	\$0		\$0
Logging Crew (2) - Operational	\$0	4.55	\$3,200	\$14,580	\$0	0	\$0		\$0
Logging programme	\$125,000	4.55	\$10,000	\$170,500	\$0	0	\$0		\$0
Wireline / TCP performing	\$0	0	\$0	\$0	\$61,154	3	\$846	0	\$0
705 CASING									
Total Casing & Completion Tangibles	\$0	1	\$0	\$0	\$0	0	\$0		\$0
30" 1.5" WT	\$0	1	\$16,500	\$16,500	\$0	0	\$16,500		\$0
20"	\$0	0	\$61,850	\$0	\$0	0	\$61,850		\$0
13-3/8"	\$0	0	\$0	\$0	\$0	0	\$0		\$0
9-5/8"	\$0	1	\$47,600	\$47,600	\$0	0	\$47,600		\$0
7" Liner	\$0	0	\$35,250	\$0	\$0	1	\$35,250	0	\$0
30" Shoe	\$0	1	\$21,775	\$21,775	\$0	0	\$21,775		\$0
20" Float Shoe & Collar	\$0	0	\$2,870	\$0	\$0	0	\$2,870		\$0
20" Centralisers & Stop Collars	\$0	1	\$0	\$0	\$0	0	\$0		\$0
13-3/8" Float Shoe & Collars	\$0	1	\$0	\$0	\$0	0	\$0		\$0
13-3/8" Centralisers & Stop Collars	\$0	1	\$0	\$0	\$0	0	\$0		\$0
9-5/8" Float Shoe & Collar + plugs	\$0	2	\$2,480	\$4,960	\$0	0	\$2,480		\$0
9-5/8" Centralisers & Stop Collars	\$0	1	\$6,200	\$6,200	\$0	0	\$6,200		\$0
7" Float Shoe & Collar (see Liner hanger!)	\$0	1	\$0	\$0	\$0	0	\$0		\$0
7" Landing Collar	\$0	1	\$0	\$0	\$0	0	\$0		\$0
7" Centralisers & Stop Collars	\$0	0	\$1,800	\$0	\$0	0	\$1,800		\$0
7" Liner Hanger	\$0	0	\$0	\$0	\$64,815	0.8	\$1,482	0	\$0
Liner Hanger Package - Consignment	\$0	0	\$0	\$0	\$0	0	\$0		\$0
Liner Hanger Package - Usage	\$0	0	\$0	\$0	\$0	0	\$0		\$0
Liner Hanger Supervisor	\$0	0	\$0	\$0	\$0	0.8	\$1,482	0	\$0
7" Bridge Plug	\$0	0	\$0	\$0	\$0	0	\$5,000		\$0
9-5/8" Bridge Plug	\$0	1	\$5,250	\$5,250	\$0	0	\$5,250		\$0
13-3/8" Bridge Plug	\$0	0	\$13,000	\$0	\$0	0	\$13,000		\$0
20"/30" AGE Packer	\$0	0	\$34,000	\$0	\$0	0	\$34,000		\$0
Casing Threadlock	\$0	1	\$0	\$0	\$0	0	\$0		\$0
Casing Dope	\$0	1	\$0	\$0	\$0	0	\$0		\$0
Restocking Charges	\$0	1	\$0	\$0	\$0	0	\$0		\$0
Pipe Inspection	\$0	1	\$0	\$0	\$0	0	\$0		\$0
Xovers & circulating swedges	\$0	9.1	\$100	\$910	\$0	0.8	\$100		\$80
20" running equipment	\$0	9.1	\$1,154	\$10,500	\$0	0.8	\$0		\$0
9-5/8" running equipment	\$0	9.1	\$1,869	\$17,010	\$0	0.8	\$0		\$0
7" 5 1/2" running equipment	\$0	0	\$0	\$0	\$0	0.8	\$1,138	0	\$0
Casing Running Crew	\$0	9.1	\$2,677	\$24,360	\$0	0.8	\$2,677		\$2,142
COMPLETION EQUIPMENT									
5 1/2" tubing	\$0	0	\$0	\$0	\$12,102	8	\$850	0	\$0
9 5/8" x 5 1/2" production packer	\$0	0	\$0	\$0	\$0	0	\$0		\$0
TR Safety Valve w/ control line	\$0	0	\$0	\$0	\$0	0	\$0		\$0
Wireline Nipples	\$0	0	\$0	\$0	\$0	0	\$0		\$0
Downhole pressure gauge w/ cable & clamps	\$0	0	\$0	\$0	\$0	0	\$0		\$0
Additional Accessories	\$0	0	\$0	\$0	\$0	0	\$0		\$0
720 COMMUNICATIONS									
Itera Satellite System	\$0	0	\$0	\$0	\$0	0	\$0		\$0
Usage charges	\$0	0	\$0	\$0	\$0	0	\$0		\$0
Hardware / Fax / Phone - Rig	\$0	0	\$0	\$0	\$0	0	\$0		\$0
Hardware / Fax / Phone - Office	\$0	0	\$0	\$0	\$0	0	\$0		\$0
Morning Reporting System	\$0	0	\$0	\$0	\$0	0	\$0		\$0
745 DRILLING BITS									
36" Hole Opener Rental	\$15,000	0	\$0	\$15,000	\$0	0	\$500		\$0
Hole Opener Cutters	\$0	0	\$0	\$0	\$0	0	\$0		\$0
26" Bit	\$15,000	0	\$0	\$15,000	\$0	0	\$0		\$0
17 1/2" Bit	\$0	0	\$0	\$0	\$0	0	\$0		\$0
12 1/4" PDC Bit	\$0	0	\$0	\$0	\$0	0	\$0		\$0
12 1/4" Bit (2 Off)	\$30,000	0	\$0	\$30,000	\$0	0	\$0		\$0
8 1/2" PDC Bit	\$0	0	\$0	\$0	\$0	0	\$0		\$0
8 1/2" Bit (2 Off)	\$40,000	0	\$0	\$40,000	\$0	0	\$0		\$0
Others	\$0	0	\$0	\$0	\$0	0	\$0		\$0
Nozzles	\$0	0	\$0	\$0	\$0	0	\$0		\$0
740 DOWNHOLE TOOLING									

General Downhole equipment - Stabs, NMDC, e	\$0	9.1	\$1,362	\$12,390	\$0	0.8	\$1,362	\$1,069
Drillpipe / Collar Handling Equipment	\$0	9.1	\$412	\$3,752	\$0	0.8	\$412	\$330
Fishing Tool Package	\$5,915	9.1	\$714	\$12,411	\$0	0.8	\$714	\$571
Clean Out Package	\$0	0	\$1,258	\$0	\$0	0.8	\$1,258	\$1,007
Abandonment Package	\$0	0	\$0	\$0	\$32,308	0	\$0	\$32,308
Abandonment services operator	\$0	0	\$0	\$0	\$0	0.8	\$1,308	\$1,046
Specialise Tools / Services	\$0	9.1	\$2,500	\$22,750	\$0	0.8	\$2,500	\$2,000
AZ One trip cut & pull severance system	\$0	0	\$0	\$0	\$0	0	\$250	\$0
30"/20" cutting charge	\$0	0	\$0	\$0	\$0	0	\$0	\$0
13-3/8" cutting charge	\$0	0	\$0	\$0	\$0	0	\$0	\$0
9-5/8" cutting charge	\$0	0	\$0	\$0	\$0	0	\$0	\$0

704 WELLSHAFTS								
Subsea Wellhead System	\$73,500	0	\$2,500	\$73,500	\$0	0	\$0	\$0
Temporary Guide & Flow Base	\$0	0	\$0	\$0	\$0	0	\$0	\$0
Running Tools - rental	\$0	0	\$0	\$0	\$0	0	\$0	\$0
Tubing Hanger c/w running tool	\$0	0	\$0	\$0	\$0	0	\$0	\$0
Subsea Xmas Tree (n/a - appraisal)	\$0	0	\$0	\$0	\$0	0	\$0	\$0
Production Riser (n/a - appraisal)	\$0	0	\$0	\$0	\$0	0	\$0	\$0
Service Engineer	\$0	9.1	\$950	\$8,645	\$0	0.8	\$950	\$760
Inspection	\$0	0	\$0	\$0	\$0	0	\$0	\$0

703 CONSULTANTS								
Consultant Office Costs	\$0	0	\$0	\$0	\$0	0	\$0	\$0
Drilling Supt. Predrill	\$0	15	\$1,850	\$27,750	\$0	0	\$0	\$0
Operations	\$0	9.1	\$1,850	\$16,835	\$0	0.8	\$1,850	\$1,480
Post-operations	\$0	0	\$0	\$0	\$0	15	\$1,850	\$27,750
Drilling Eng. Predrill	\$0	30	\$1,350	\$40,500	\$0	0	\$0	\$0
Operations	\$0	9.1	\$1,350	\$12,285	\$0	0.8	\$1,350	\$1,080
Post-operations	\$0	0	\$0	\$0	\$0	15	\$1,350	\$20,250
Petroleum En Predrill	\$0	15	\$1,350	\$20,250	\$0	0	\$0	\$0
Operations	\$0	9.1	\$1,350	\$12,285	\$0	0.8	\$1,350	\$1,080
Post-operations	\$0	0	\$0	\$0	\$0	0	\$1,350	\$0
Materials Ma Predrill	\$0	30	\$850	\$25,500	\$0	0	\$0	\$0
Operations	\$0	10	\$850	\$8,500	\$0	0.8	\$850	\$680
Post-operations	\$0	0	\$0	\$0	\$0	0	\$0	\$0
Reps (Day/Ni) Predrill	\$0	0	\$0	\$0	\$0	0	\$0	\$0
Operations	\$0	9.1	\$2,880	\$26,208	\$0	0.8	\$2,880	\$2,304
Post-operations	\$0	0	\$0	\$0	\$0	0	\$0	\$0
Wellsite Geo. Predrill	\$0	0	\$0	\$0	\$0	0	\$0	\$0
Operations	\$0	9.1	\$1,000	\$9,100	\$0	0.8	\$1,000	\$800
Post-operations	\$0	0	\$0	\$0	\$0	0	\$0	\$0
Testing Rep. Predrill	\$0	0	\$0	\$0	\$0	0	\$0	\$0
Operations	\$0	0	\$0	\$0	\$0	0	\$0	\$0
Post-operations	\$0	0	\$0	\$0	\$0	0	\$0	\$0
Environmenta Predrill	\$0	0	\$0	\$0	\$0	0	\$0	\$0
Operations	\$0	0	\$0	\$0	\$0	0	\$0	\$0
Post-operations	\$0	0	\$0	\$0	\$0	0	\$0	\$0
Oil Spill Rep Predrill	\$0	15	\$1,150	\$17,250	\$0	0	\$0	\$0
Operations	\$0	9.1	\$1,150	\$10,465	\$0	0.8	\$1,150	\$920
Post-operations	\$0	0	\$0	\$0	\$0	30	\$1,150	\$34,500

876 TIME WRITING								
Geologist Predrill	\$0	15	\$1,000	\$15,000	\$0	0	\$1,000	\$0
Operations	\$0	9.1	\$1,000	\$9,100	\$0	0.8	\$1,000	\$800
Post-operations	\$0	0	\$1,000	\$0	\$0	30	\$1,000	\$30,000
Exp. Mgr. Predrill	\$0	15	\$1,500	\$22,500	\$0	0	\$1,500	\$0
Operations	\$0	9.1	\$1,500	\$13,650	\$0	0.8	\$1,500	\$1,200
Post-operations	\$0	0	\$1,500	\$0	\$0	30	\$1,500	\$45,000

770 FUEL AND LUBES									
Rig On Tow	\$0	0	\$0	\$0	\$0	0	\$650	\$0	
Operational	\$0	9.1	\$650	\$59,150	\$0	0.8	\$650	\$5,200	
Workboat On Tow	\$0	0	\$0	\$0	\$0	0	\$650	\$0	
Operational	\$0	9.1	\$650	\$6.5	\$38,448	\$0	0.8	\$650	\$6.5
S/by Boat On Tow	\$0	0	\$0	\$0	\$0	0	\$650	\$0	
Operational	\$0	9.1	\$650	\$5	\$29,575	\$0	0.8	\$650	\$5

786 INSURANCE/ACCOUNTING/LEGAL								
Insurance	\$0	0	\$0	\$0	\$0	0	\$0	\$0
Accounting	\$0	0	\$0	\$0	\$0	0	\$0	\$0
Legal fees, registration & stamp duty	\$0	0	\$0	\$0	\$0	0	\$0	\$0

840 ENVIRONMENTAL AND SAFETY								
Oil Spill Contingency Response Plan	\$25,000	0	\$0	\$25,000	\$0	0	\$0	\$0
Trajectory Modelling	\$0	0	\$0	\$0	\$0	0	\$0	\$0
Emergency Response Manual or Safety Plan	\$0	0	\$0	\$0	\$0	0	\$0	\$0
Environmental Assessment Plan	\$0	0	\$0	\$0	\$0	0	\$0	\$0
Safety and Well Control Bridging Document	\$0	0	\$0	\$0	\$0	0	\$0	\$0
Offshore Booklet	\$0	0	\$0	\$0	\$0	0	\$0	\$0

810 ANALYTICAL SERVICES								
Paleontology, core study estimate	\$0	0	\$0	\$0	\$0	0	\$0	\$0

872 DRAFTING AND CONSUMABLES								
Materials / Supplies	\$40,000	9.1	\$1,500	\$53,650	\$0	0	\$1,500	\$0

OTHERS								
Water	\$0	9.1	\$300	\$2,730	\$0	0	\$300	\$0
Survey	\$0	0	\$0	\$0	\$0	0	\$0	\$0

TOTAL WELL COSTS				\$5,089,185	\$4,069,150			
-------------------------	--	--	--	-------------	--------------------	--	--	--

WELL AFE - COST TRACKING

Well: Patricia - Baleen
 Area: VIC RL-5
 Permit: VERTICAL APPRAISAL WELL
 Country: Australia
 AFE No: 99-RL5-41

Rig on Hire: 7/10/99
 Spud Date: 11/10/99

Category	Calculations	Comments	Mon	Tue	Wed	Thu	Fri	Sat	Sun	Mon	Tue	Day	Day	Post Year
	Fixed Rate		Day	Day	Day	Day	Day	Day	Day	Day	Day	Day	Day	Day
OFFSHORE RIGS AND POSITIONS														
Site Survey (Seabed)	\$0	\$7,620												
Rig Positioning	\$1,750	\$2,540												
Hydrographic Survey QA/QC	\$350	\$550												
EQUIPMENT TRANSPORT AND MOBILIZATION														
Mids / Demob work boats	\$0	\$38,100												
Mobilisation rig	\$0	\$102,308												
Demobilisation rig	\$615,365	\$0												
Demobilisation services	\$0	\$0												
Standy Rate	\$0	\$92,308												
Counter	\$0	\$0												
TRAVEL AND ACCOMMODATION														
Airfares	\$0	\$3,500												
Accommodation	\$0	\$600												
HELICOPTERS														
Helicopters Demob	\$5,000	\$0												
Helicopters Standby	\$0	\$5,066												
Flying Rate: per flight / 2 hr flight	\$0	\$2,960												
Base Charges	\$0	\$0												
SUPPLY VESSELS														
Main Supply Vessel	\$0	\$19,050												
Standby Vessel	\$0	\$19,050												
WARRANTAGE AND INTERVEDORING														
Port of Geelong	\$0	\$0												
Port of Melbourne	\$0	\$0												
Warehouse, yard, etc.	\$0	\$5,500												
Stevedoring	\$0	\$0												
Dates F&I and bonds	\$0	\$0												
Rental equipment (slips, etc)	\$0	\$0												
OFFSHORE OPERATIONS EXPENSES														
Weather forecast (rig move)	\$0	\$118												
Weather forecast (rig operations)	\$0	\$118												
OTHERS														
Mobilisation	\$0	\$0												
Demobilisation	\$0	\$0												
ROV, Control Cabin - Operating	\$0	\$1,615												
ROV, Control Cabin - Standby	\$0	\$0												
ROV, Control Cabin - Transit	\$0	\$1,308												
Senior pilot (or crew)	\$0	\$2,615												
Pilot Technician	\$0	\$0												
Consumables	\$0	\$0												
CONTRACT RATES														
Operating Rate	\$0	\$107,692												
Standby Rate	\$0	\$102,308												
Demobilisation	\$615,365	\$0												
CONTRACTS CURTAINING														
Excess meals / accommodation	\$0	\$1,000												

Category	Comments	Calculations		Days	Multipl. Cost	Day 1	Day 2	Day 3	Day 4	Day 5	Day 6	Day 7	Day 8	Day 9	Day 10	Perf. Well
		Fixed	Rate													
Logistics Supp. Operations		\$0	\$650	14	\$0,1100	\$650	\$650	\$650	\$650	\$650	\$650	\$650	\$650	\$650	\$650	\$0
Post-operations		\$0	\$0													\$0
Environmental Operations		\$0	\$650	5	\$3,250	\$650	\$650	\$650	\$650	\$650	\$650	\$650	\$650	\$650	\$650	\$1,216
Post-operations		\$0	\$0													\$0
TIME WASTING																
Geologist Operations		\$0	\$900	10	\$9,000	\$900	\$900	\$900	\$900	\$900	\$900	\$900	\$900	\$900	\$900	\$1,000
Post-operations		\$0	\$0													\$0
Exp. Mgr. Operations		\$0	\$1,500	5	\$7,500	\$1,500	\$1,500	\$1,500	\$1,500	\$1,500	\$1,500	\$1,500	\$1,500	\$1,500	\$1,500	\$4,348
Post-operations		\$0	\$0													\$0
Ops. Mgr. Operations	5 days/month	\$0	\$1,800	5	\$9,000	\$900	\$900	\$900	\$900	\$900	\$900	\$900	\$900	\$900	\$900	\$1,000
Post-operations		\$0	\$0													\$0
PIPE AND TUBING																
Rig On Tow Operational	8.2 MT/day	\$0	\$2,851	4	\$11,404	\$3,651	\$4,346	\$4,502	\$4,033	\$3,373	\$2,747	\$3,894	\$4,346	\$2,573	\$0	\$0
On Tow Operational (PS)	15 MT/day	\$0	\$5,215	4	\$34,768	\$3,651	\$3,968	\$3,381	\$862	\$1,321	\$1,208	\$1,339	\$4,346	\$1,669	\$0	\$0
Shy Boat On Tow Operational (PC)	10 MT/day	\$0	\$3,477	4	\$34,768	\$3,651	\$868	\$1,947	\$1,947	\$868	\$4,682	\$2,598	\$4,346	\$800	\$0	\$0
Operational (PC)	23 MT/day	\$0	\$3,477													\$0
Operational (PC)	10 MT/day	\$0	\$3,477													\$0
INSURANCE, ACCOUNTING & LEGAL																
ENVIRONMENTAL IMPACT																
Oil Spill Contingency Response Plan		\$0,000	\$0		\$0,000	\$0	\$0	\$0	\$0	\$0	\$0	\$0	\$0	\$0	\$0	\$0
Tragedy Modeling		\$0,000	\$0		\$0,000	\$0	\$0	\$0	\$0	\$0	\$0	\$0	\$0	\$0	\$0	\$0
Emergency Response Manual or Safety Plan		\$0	\$0		\$0	\$0	\$0	\$0	\$0	\$0	\$0	\$0	\$0	\$0	\$0	\$0
Environmental Assessment Plan		\$4,000	\$0		\$4,000	\$0	\$0	\$0	\$0	\$0	\$0	\$0	\$0	\$0	\$0	\$0
Safety and Well Control Bridging Document		\$0	\$0		\$0	\$0	\$0	\$0	\$0	\$0	\$0	\$0	\$0	\$0	\$0	\$0
Officers Booklet		\$0	\$0		\$0	\$0	\$0	\$0	\$0	\$0	\$0	\$0	\$0	\$0	\$0	\$0
ANALYTICAL SERVICES - NOT INCLUDED																
MAINTENANCE AND CONSUMABLES																
Materials / Supplies		Fixed	Rate		\$10,000	\$1,000	\$1,000	\$1,000	\$1,000	\$1,000	\$1,000	\$1,000	\$1,000	\$1,000	\$1,000	\$1,000
OTHER		Fixed	Rate		\$0	\$300	\$300	\$300	\$300	\$300	\$300	\$300	\$300	\$300	\$300	\$0
Water		Fixed	Rate		\$0	\$300	\$300	\$300	\$300	\$300	\$300	\$300	\$300	\$300	\$300	\$0
TOTAL WELL COSTS																
Daily Total					\$966,653	\$350,730	\$282,861	\$319,624	\$176,843	\$231,675	\$315,432	\$305,101	\$215,400	\$848,003	\$17,583	\$227,230
Accumulated Total					\$966,653	\$1,317,383	\$1,580,044	\$1,899,668	\$2,076,511	\$2,308,187	\$2,623,619	\$2,928,720	\$3,144,120	\$3,992,123	\$4,009,706	\$4,236,936

903058 031

1.7 Days Vs Depth

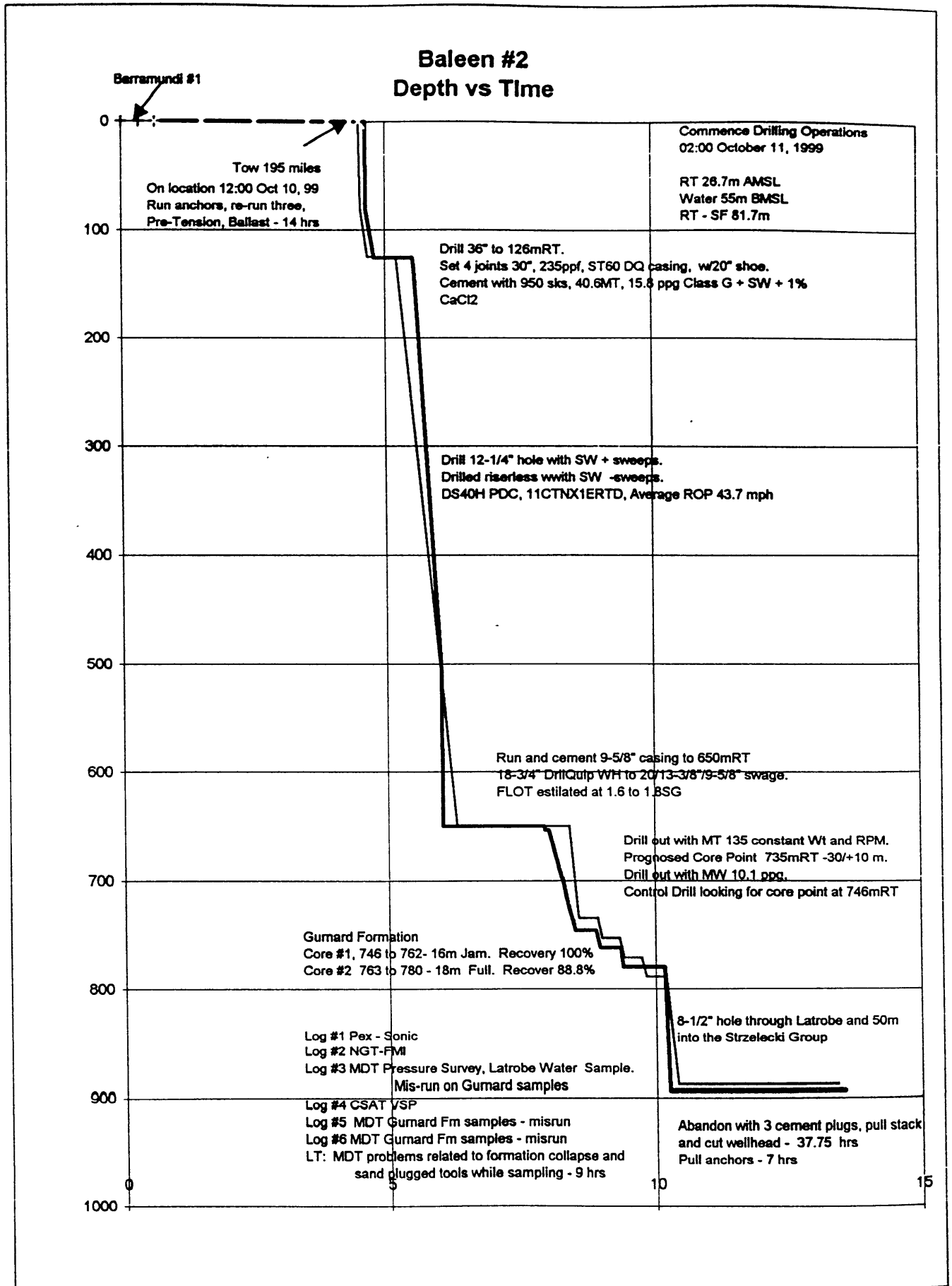

WELL : BALEEN #2

Pacesetter Well : none selected

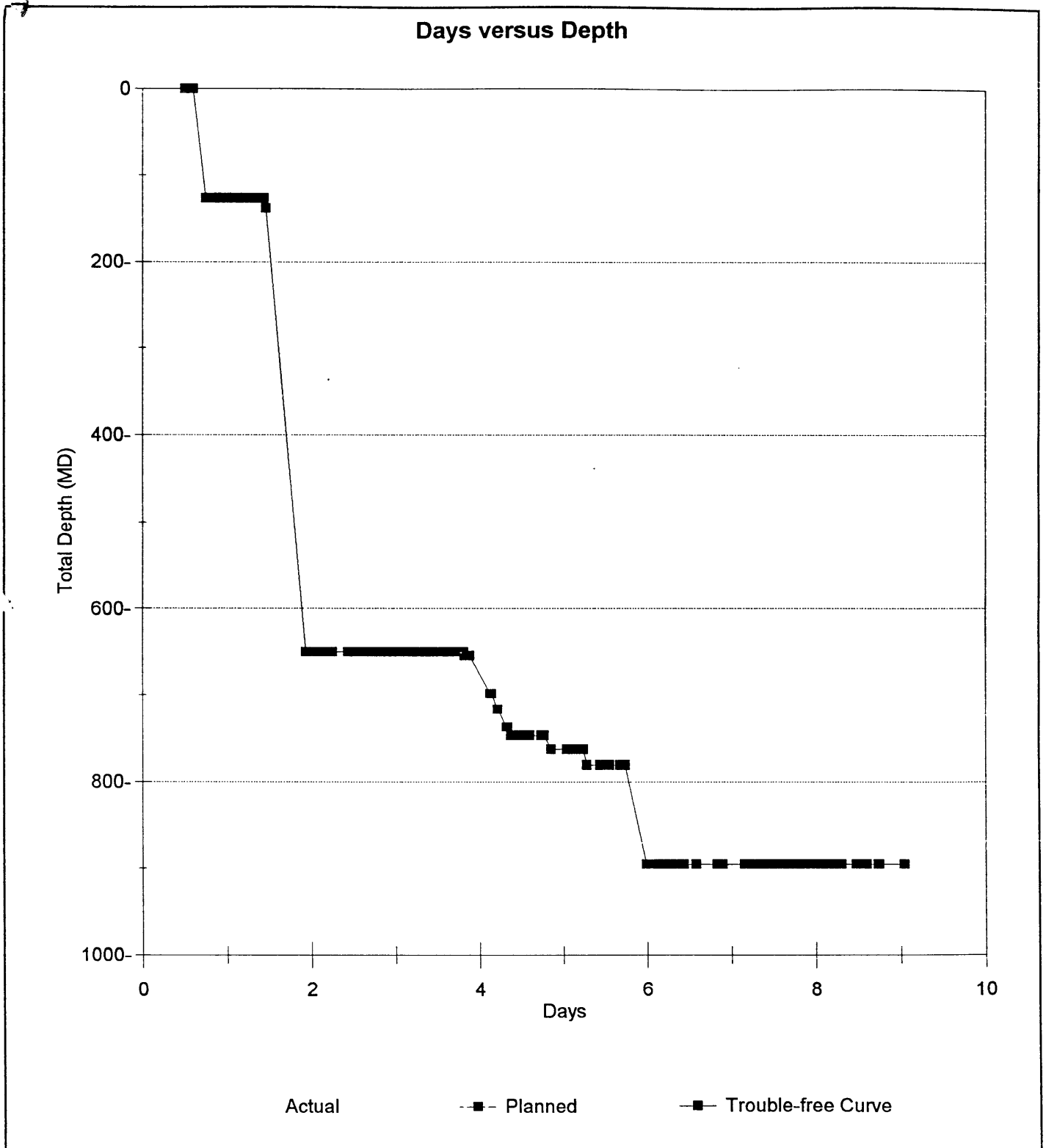

1.8 Purchasing / Logistics

1.8.1 Materials

Equipment was sourced from stocks already available on the ground in Australia.

Drilquip supplied the well head equipment e.g. Darwin, within the time constraint. This was supplemented with the intermediate joints of 30" being supplied ex Cultus stock. We also considered using 9-5/8" casing we had in Darwin, however, it worked out cheaper to source casing from Esso which was available ex Barry Beach Marine Terminal at an extremely good price.

Material expenditure including wellhead 30" and 9-5/8" casing etc. totalled A\$268,000.

Recommendation: The decision to drill Baleen 2 was made 4 weeks prior to actual spud leaving minimal time to optimise equipment purchase and delivery. More time in planning and purchasing equipment would benefit the operation.

1.8.2 Supply Vessels

The initial load out was from Geelong Wharf (Base used by Globex). At the same time we visited the port of Welshpool and established that it would be much cheaper and quicker turn around time (30 hours versus 12 hours sailing time each way) to work out of Welshpool. Welshpool up until recently had a 10 ton limit on the wharf. The wharf has recently been upgraded to a road axle weight (53 ton). The only constraint is the water depth over the sand bar during low tide.

Recommendation: Should Patricia/Baleen be developed as a producing gas field consideration should be given to using Welshpool being ideal with its close proximity to the field. The harbour master has also indicated that if warranted they would dredge to remove the sand bar.

1.8.3 Helicopter

The existing contractual arrangement Cultus had with Lloyds was extended to the Baleen 2 project. Initially we looked at basing the operation at West Sale. However, we decided to work out of Essendon with refuelling at West Sale, as well as picking up and dropping off passengers as and when requested.

By working out of Essendon, overnight stays in Melbourne were reduced with all travellers being able to get to the rig on the same day from anywhere in Australia, likewise their return journey home. This also alleviated the need for rental vehicles between Melbourne airport and Sale reducing the likelihood of motor vehicle accidents.

908058 036

2. TIME BREAKDOWNS

903058 037

TIME BREAKDOWN DATABASE - single well overview

908058 038

Well : **BALEEN #2**
 Drilling Co : **Sedco Forex**
 Rig : **702**
 Spud Date : **10/10/99**
 TD Depth : **895.0**

Page 1

Total Time (hrs) - Spud/Release : **227.50**
 Total Time (hrs) - Rig Move : **0.00**
 Total NPT (hrs) : **10.50**

Time-Breakdown : Times by Class and Operation

Class	Hrs	Operation	Hrs
PLANNED DRILLING	123.50	TOT. TRIPPING	41.00
PLANNED EVALUATION	48.75	BOP : NIPPLE U/D AND TEST	27.50
PLANNED ABANDON	44.75	DRILLING AHEAD	22.00
TROUBLE EVALUATING	9.00	ANCHOR HANDLING	21.00
TROUBLE DRILLING	1.50	LOGGING	20.25
		TOT. CSG/CMT	11.75
		HANDLE TOOLS	11.75
		CONTROL DRILL (EVAL)	11.00
		HANDLE BHA	10.75
		CIRCULATE & CONDITION MUD	8.75
		CASING - RUN	7.00
		CORING	5.25
		WELL-HEAD	4.50
		PIPE - LAY DOWN	4.00
		CASING - CUT	3.25
		WIPER TRIP	3.00
		RUN & SET PACKERS	2.75
		CEMENT ABANDONMENT/KICK	2.25
		PIPE - PICKUP	2.00
		REAM/WASH	2.00
		CIRCULATE SAMPLE	1.50
		WAIT ON OTHER	1.25
		EXERCISE/DRILL	1.00
		RISER - RUN	0.75
		LEAK-OFF TEST	0.50
		RIG REPAIR	0.50
		SURVEY	0.25

WELL : BALEEN #2

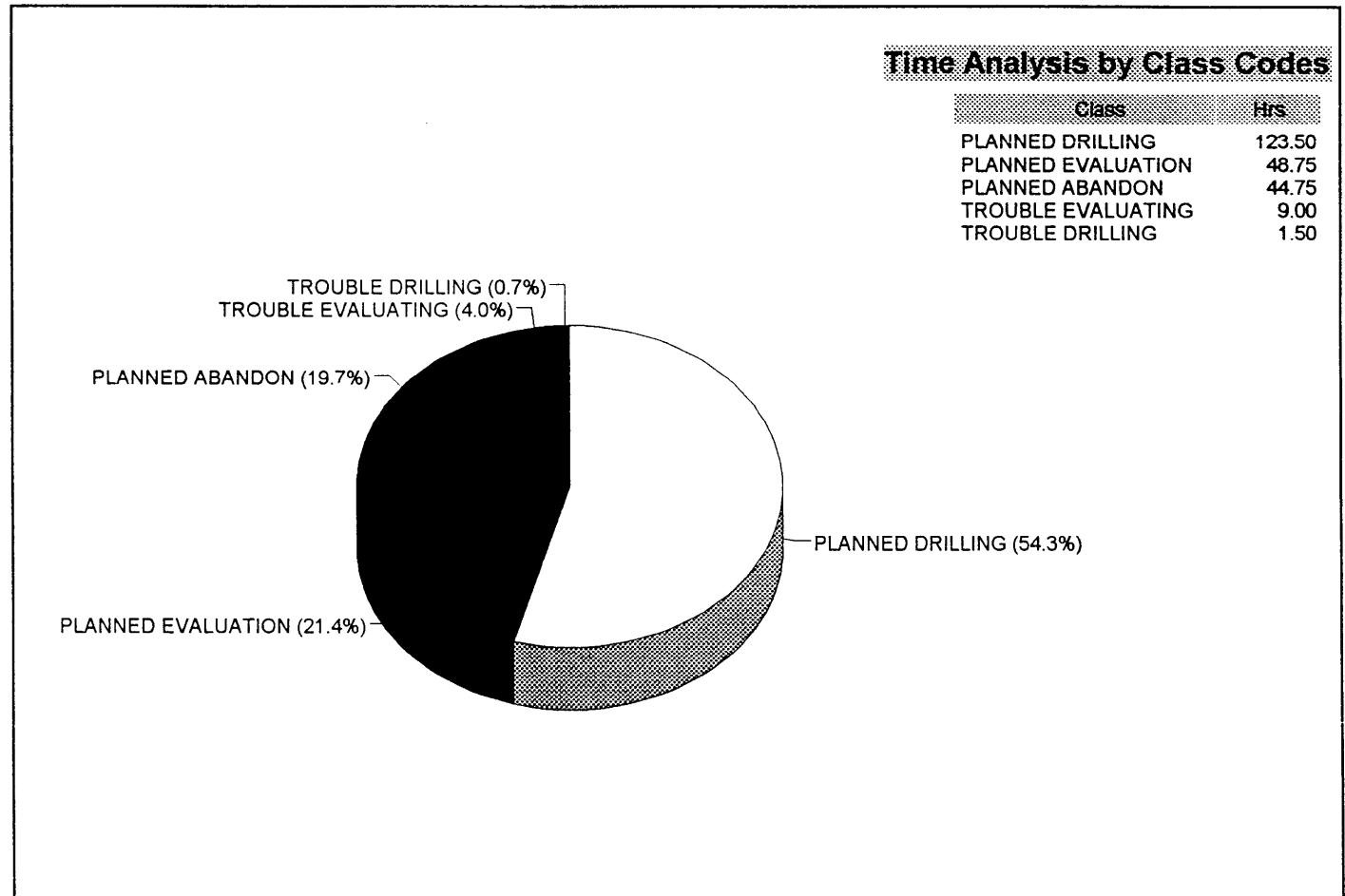
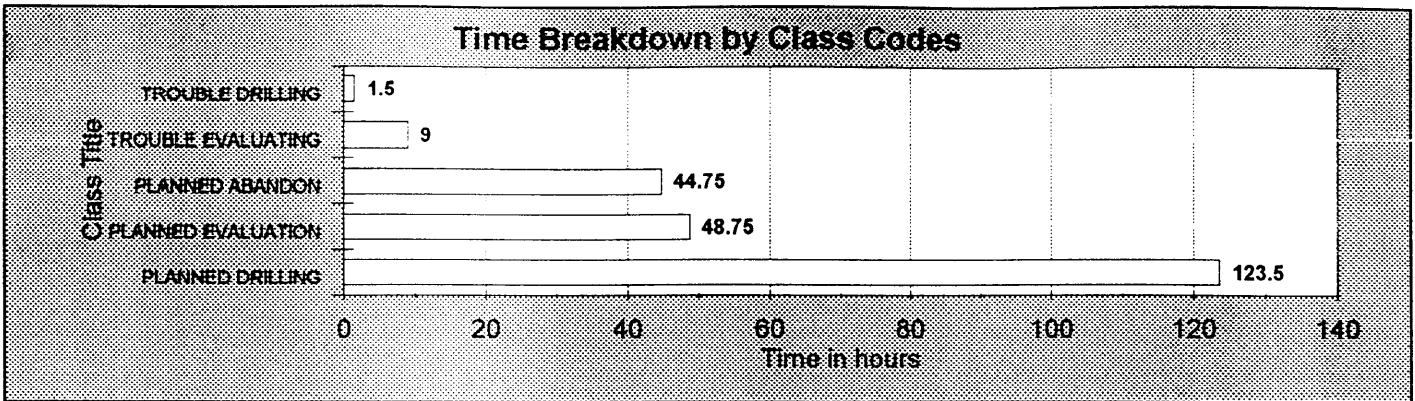

WELL : BALEEN #2

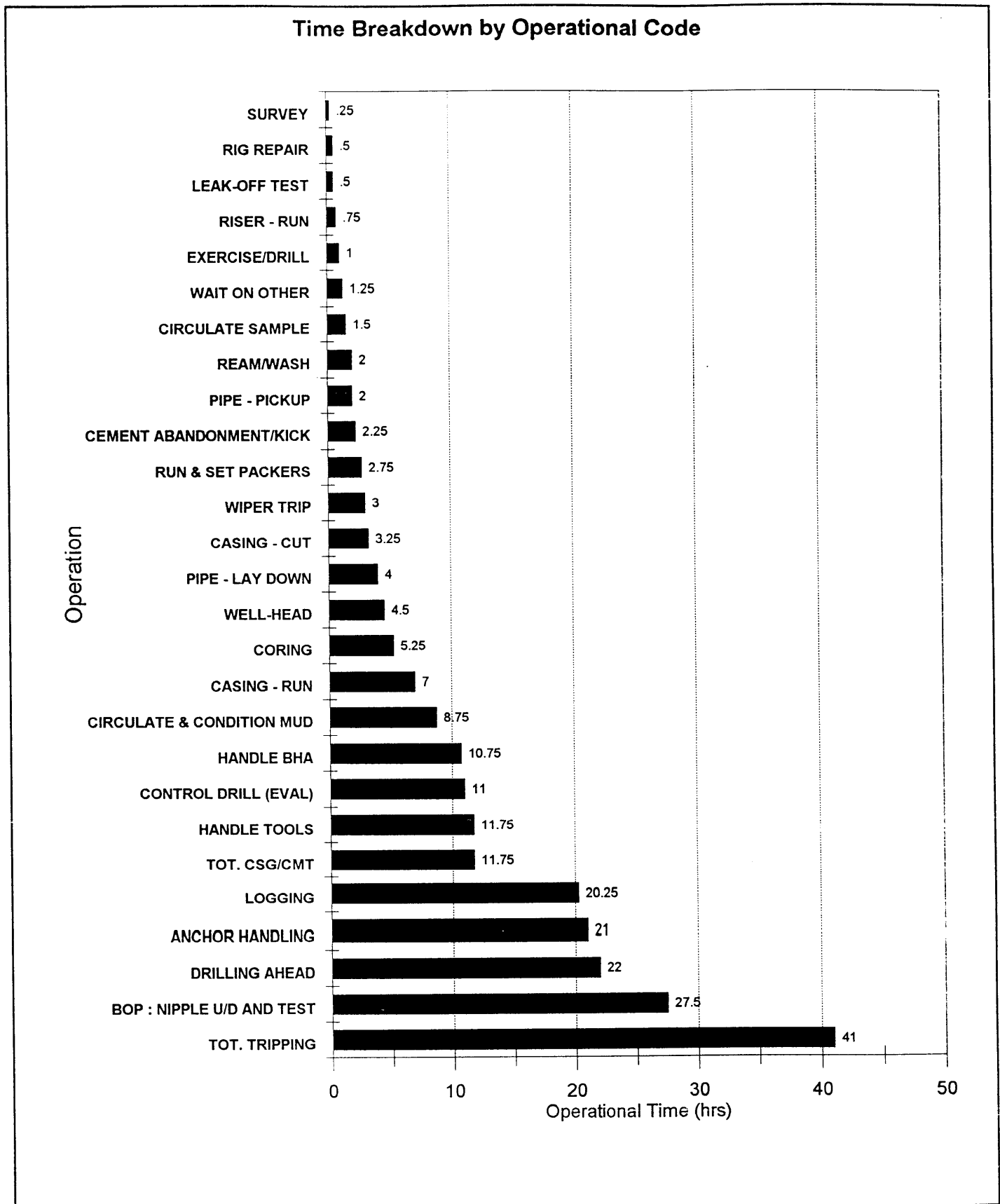

TIME BREAKDOWN DATABASE - single well overview

WELL : BALEEN #2

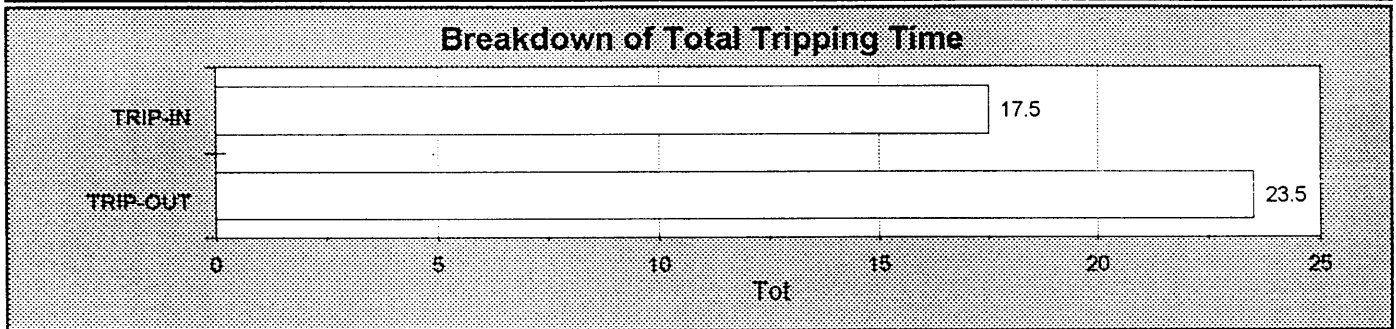
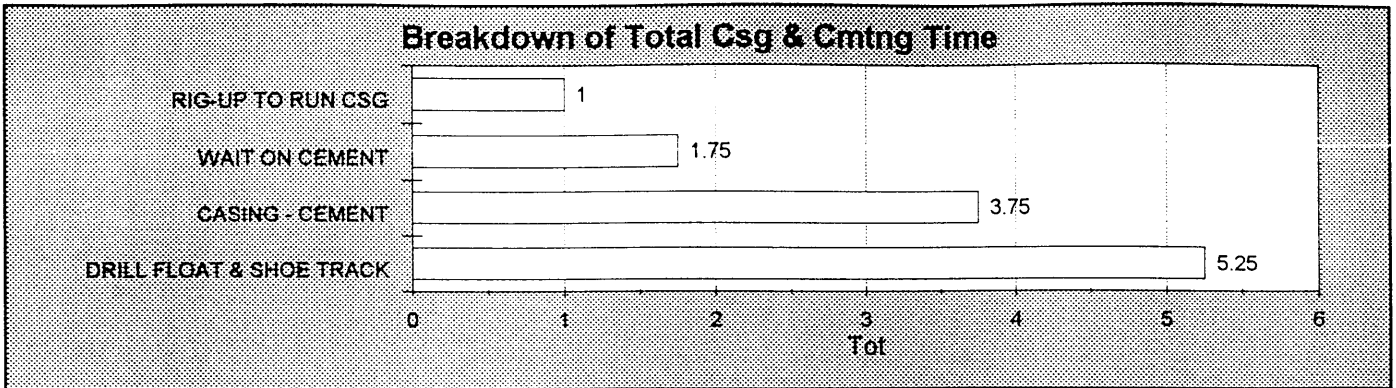

Time Analysis by Operational Codes

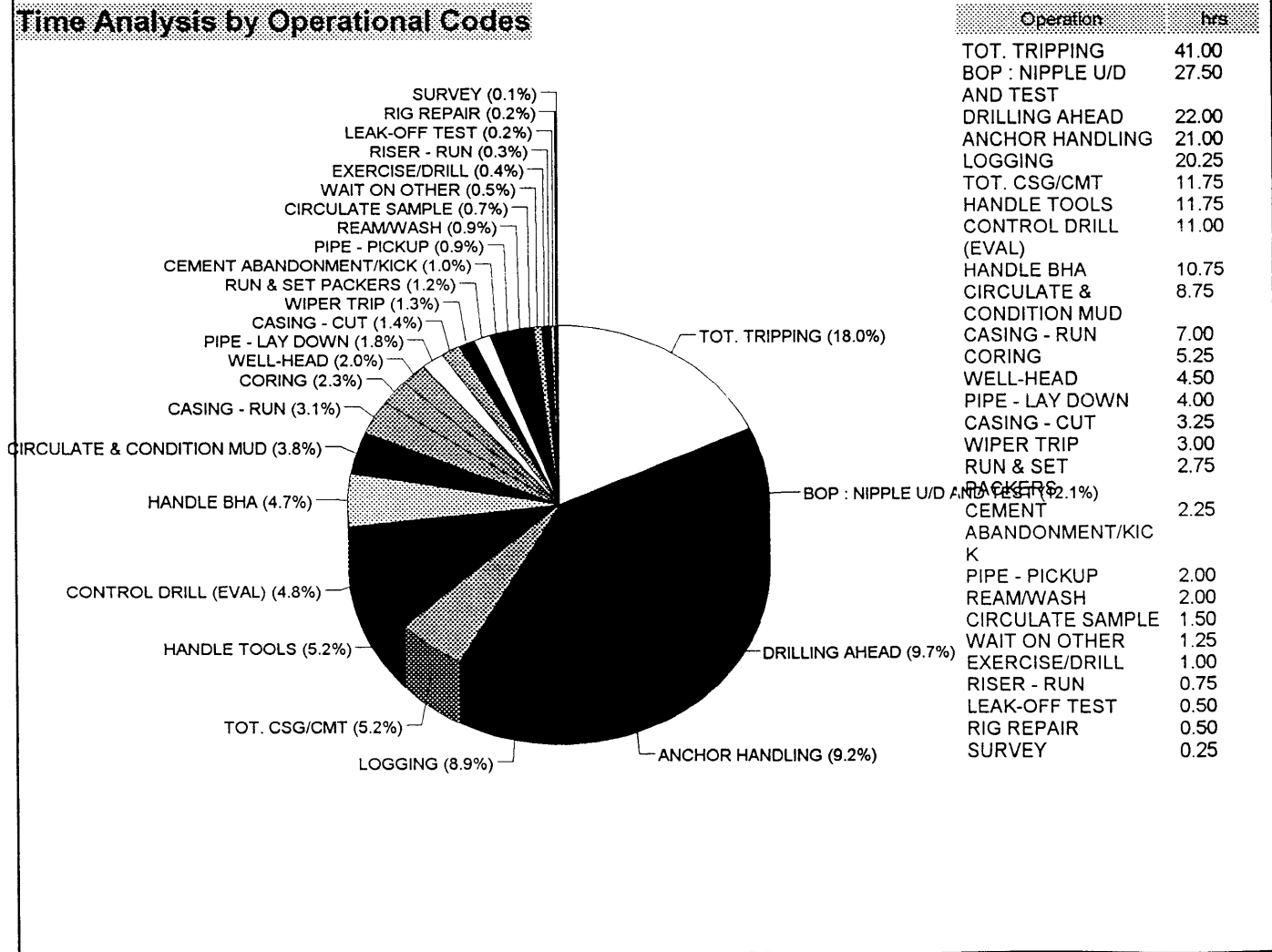

Operation	hrs
TOT. TRIPPING	41.00
BOP : NIPPLE U/D AND TEST	27.50
DRILLING AHEAD	22.00
ANCHOR HANDLING	21.00
LOGGING	20.25
TOT. CSG/CMT	11.75
HANDLE TOOLS	11.75
CONTROL DRILL (EVAL)	11.00
HANDLE BHA	10.75
CIRCULATE & CONDITION MUD	8.75
CASING - RUN	7.00
CORING	5.25
WELL-HEAD	4.50
PIPE - LAY DOWN	4.00
CASING - CUT	3.25
WIPER TRIP	3.00
RUN & SET PACKERS	2.75
CEMENT ABANDONMENT/KICK	2.25
PIPE - PICKUP	2.00
REAM/WASH	2.00
CIRCULATE SAMPLE	1.50
WAIT ON OTHER	1.25
EXERCISE/DRILL	1.00
RISER - RUN	0.75
LEAK-OFF TEST	0.50
RIG REPAIR	0.50
SURVEY	0.25

ACTIVITY REPORT

908058 044

WELL : BALEEN #2
 Drilling Co : Sedco Forex
 Rig : 702

Page Number : 1 of 5

Date : 10/10/99

Depth	Phase Class	Operation	Hrs	Activity
0	RMO PD	ANCHOR HANDLING	12.00	Arrive on location. Run and pre-tension anchors in pairs to 350 kips. Position rig. Set tensions at 250 kips. Pre-mix mud. run casing and hang off w/ PGB in moonpool. Sonsub perform bottom survey.

Date : 11/10/99

Depth	Phase Class	Operation	Hrs	Activity
0	RMO PD	ANCHOR HANDLING	2.00	Pre-tension anchors. Surveyor and QAQC confirm final rig position.
0	SH PD	TRIP-IN	0.25	RIH w/ 36" BHA. Tag seabed at 80.7m Confirm w/ ROV
126	SH PD	DRILLING AHEAD	3.75	Drill 26" hole to 125.7mRT w/ 36" hole opener positioned at 123.8mRT. Sweep hole w/ HiVis pills.
126	SH PD	CIRCULATE & CONDITION	1.00	Sweep hole w/ 50bbl HiVis gel and displace hole w/ same (prehydrated bentonite).
126	SH PD	TRIP-OUT	1.00	POOH. Recover Totco survey. Rack back BHA.
126	CON PD	CASING - RUN	2.00	Run 30" casing, 4 jnts 235 lb/ft w/ ST60 connectors. Land 30" housing w/ PGB 1m above seabed.
126	CON PD	CASING - CEMENT	1.25	Hold JHA. R/U and pressure test lines to 2500psi. Cement 30" w/ 950sx "G" w/ 1% CaCl at 15.8ppg.
126	CON PD	HANDLE BHA	0.75	Check bullseye 0.5deg. POOH w/ R.tool. Flush drillpipe. L/D same.
126	SH PD	HANDLE BHA	1.50	L/D 36" drilling BHA.
126	CON PD	HANDLE BHA	0.25	SLM 30" running string.
126	IH1 PD	HANDLE BHA	1.00	M/U 17 1/2" drilling BHA and RIH into moonpool. Attach guide ropes.
126	IH1 PD	WAIT ON CEMENT	1.25	Wait on Cement
126	IH1 PD	EXERCISE/DRILL	1.00	Hold Emergency winch-off drill. Move rig 150ft forward. Return to hole.
126	IH1 PD	TRIP-IN	0.50	RIH w/ 17 1/2" drilling BHA. ROV assist stab into 30" housing.
126	IH1 TD	WAIT ON CEMENT	0.50	Wait on Cement
126	IH1 PD	REAMWASH	0.50	Wash down f/ 105m to 120m Tag TOC at 120m.
126	IH1 PD	DRILL FLOAT & SHOE TRA	2.00	Drill out cement and 20" shoe at 126m.
126	IH1 PD	CIRCULATE & CONDITION	0.25	Sweep hole w/ HiVis pill.
126	IH1 PD	TRIP-OUT	1.00	POOH. L/D 17 1/2" drilling BHA.
126	IH1 TD	RIG REPAIR	0.50	Repair Geoservices RPM sensor. Service TDS and travelling block.
126	IH1 PD	TRIP-IN	1.25	M/U 12 1/4" drilling BHA and bit. RIH to 126m. ROV assist through wellhead.
137	IH1 PD	DRILLING AHEAD	0.50	Drill 12 1/4" hole to 137mRT

Date : 12/10/99

Depth	Phase Class	Operation	Hrs	Activity
650	IH1 PD	DRILLING AHEAD	11.50	Drill 12 1/4" hole f/ 137m to 650mRT, survey each 100m using Anderdrift Vertical Inclination Indicator.
650	IH1 PD	CIRCULATE & CONDITION	0.25	Circulate 50 bbl HiVis pill to seabed.
650	IH1 PD	WIPER TRIP	2.00	Drop magnetic single shot. Wipertrip to 110m. Hole in good condition.
650	IH1 PD	SURVEY	0.25	Recover survey, 0.25deg.
650	IH1 PD	WIPER TRIP	1.00	RIH to 650m w/ 2m soft fill.
650	IH1 PD	CIRCULATE & CONDITION	0.75	Sweep hole w/ 50 bbl HiVis pill. Displace hole with excess viscous bentonite (150% hole volume).
650	IH1 PD	TRIP-OUT	2.25	POOH to run 9 5/8" casing. Hole in good condition. Jet PGB.
650	IC1 PD	RIG-UP TO RUN CSG	1.00	Rig up to run casing. Hold JHA.

WELL :BALEEN #2

Date : 12/10/99

Depth	Phase	Class	Operation	Hrs	Activity
650	IC1	PD	CASING - RUN	4.50	P/U and test shoe track. RIH with 47 jts, 9 5/8", 47 lb/ft, L80, LTC casing.
650	IC1	PD	CASING - RUN	0.50	M/U 9 5/8" N.VAM x LTC crossover. Fill up casing. R/D running equipment.

Date : 13/10/99

Depth	Phase	Class	Operation	Hrs	Activity
650	IC1	PD	WELL-HEAD	1.00	M/U 18 3/4" SS-10C wellhead. Install R.tool and SSR cement plugs. Fill w/ water above plugs.
650	IC1	PD	WELL-HEAD	1.25	RIH w/ 9 5/8" casing. Observe landing in wellhead housing w/ ROV. Apply 50 Klbs overpull with tensioners to confirm latch.
650	IC1	PD	CASING - CEMENT	2.50	Hold cementing JHA. R/U dowell. Test to 3000psi. Drop ball and shear plug. Pump 20bbl fresh water spacer. Pump 479sx lead "G" w/ 14.9 gal/10bbl econolite at 12.5ppg wt. Pump 227sx tail neat "G" at 15.8ppg wt. Shear dart w/ 3000psi. Displace 130.3bbl seawater w/ Dowell. Plug did not bump. (128.5bbl theoretical)
650	IC1	PD	HANDLE BHA	1.75	Back out R.tool. POOH cmt head. Jet wellhead. L/D R.tool and plug launcher.
650	IC1	PD	BOP : NIPPLE U/D AND TES	1.00	Clear rigfloor. R/U to run BOP's
650	IC1	PD	BOP : NIPPLE U/D AND TES	2.50	Hold JHA. P/U and rack double of riser. Move BOP and LRMP on moonpool spider.
650	IC1	PD	BOP : NIPPLE U/D AND TES	1.75	Function test BOP
650	IC1	PD	BOP : NIPPLE U/D AND TES	2.25	P/U riser double. M/U to LMRP. Run BOP.
650	IC1	PD	BOP : NIPPLE U/D AND TES	0.25	P/Test choke and kill lines to 5000psi. (Rig at 80ft draft.)
650	IC1	PD	BOP : NIPPLE U/D AND TES	2.50	Install slip joint, ruckers, choke/kill goosenecks and storm loops.
650	IC1	PD	BOP : NIPPLE U/D AND TES	0.25	P/test choke and kill lines w/ dowell to 5000psi against failsafe v/v.
650	IC1	PD	BOP : NIPPLE U/D AND TES	0.25	Land BOP and latch connector. ROV confirm. Take 50 Klbs overpull.
650	IC1	PD	BOP : NIPPLE U/D AND TES	2.00	Stroke out slip joint. Install divertor.
650	IC1	PD	BOP : NIPPLE U/D AND TES	0.50	L/D 500ton handling equipment and P/U 350ton. Rig at 85ft draft.
650	IC1	PD	BOP : NIPPLE U/D AND TES	0.25	Pressure test connector against shear rams and casing to 1500psi.
650	IC1	PD	BOP : NIPPLE U/D AND TES	1.00	M/U BOP test tool. RIH.
650	IC1	PD	BOP : NIPPLE U/D AND TES	0.25	Function test BOP w/ yellow pod.
650	IC1	PD	BOP : NIPPLE U/D AND TES	1.00	Pressure test failsafe valves from inside against annular to 250/1500psi.
650	IC1	PD	BOP : NIPPLE U/D AND TES	0.50	Function test BOP w/ blue pod
650	IC1	PD	BOP : NIPPLE U/D AND TES	1.00	Perform depletion test on accumulator.
650	IC1	PD	BOP : NIPPLE U/D AND TES	0.25	R/D dowell and POOH w/ test plug

Date : 14/10/99

Depth	Phase	Class	Operation	Hrs	Activity
650	IC1	PD	BOP : NIPPLE U/D AND TES	0.25	POOH w/ BOP test plug.
650	IC1	PD	BOP : NIPPLE U/D AND TES	0.25	Function test divertor. Pump through port and starboard lines.
650	IC1	PD	BOP : NIPPLE U/D AND TES	0.75	L/D BOP test plug. Stand back HWDP.
650	IC1	PD	RISER - RUN	0.75	RIH/ flex joint wearbushing.
650	IC1	PD	HANDLE BHA	1.50	L/D 12 1/4" drilling BHA.
650	PH	PD	TRIP-IN	2.25	P/U 8 1/2" BHA. RIH. Tag TOC at 596m (26m above landing collar).
650	PH	TD	DRILL FLOAT & SHOE TRA	0.50	Drill out cement f/ 596m.
650	PH	PD	DRILL FLOAT & SHOE TRA	2.75	Drill out shoetrack to 650mRT.
654	PH	PD	DRILLING AHEAD	0.25	Drill 4m new hole to 654m.
654	PH	PD	CIRCULATE & CONDITION	1.00	Sweep hole w/ 50bbl HiVis gel followed by 50bbl seawater. Displace hole and choke & kill lines w/ 10.1ppg mud (NaCl/PHPA).

Date : 14/10/99

Depth	Phase	Class	Operation	Hrs	Activity
654	PH	PD	LEAK-OFF TEST	0.50	Perform FIT w/ 560psi at 654m. Equivalent to 15.1ppg (1.81sg).
698	PH	PD	CONTROL DRILL (EVAL)	5.75	Drill 8 1/2" hole f/ 654m to 698m. Control ROP to +/- 15m/hr.
698	PH	PD	CIRCULATE SAMPLE	0.50	Flow check drilling break. Circulate bottom sample.
716	PH	PD	CONTROL DRILL (EVAL)	1.75	Drill 8 1/2" hole f/ 698m to 716m. Control ROP to +/- 15 m/hr.
					Flow check drilling break.
736	PH	PD	CONTROL DRILL (EVAL)	2.50	Drill 8 1/2" hole f/ 716m to 736m, w/ controlled ROP.
736	PH	PD	CIRCULATE SAMPLE	0.25	Circulate bottom sample.
746	PH	PD	CONTROL DRILL (EVAL)	1.00	Drill 8 1/2" hole f/ 736m to 746m, w/ controlled ROP.
746	PH	PD	CIRCULATE SAMPLE	0.75	Circulate bottom sample.
746	PH	PD	TRIP-OUT	0.75	Flow check. POOH for core #1

Date : 15/10/99

Depth	Phase	Class	Operation	Hrs	Activity
746	PH	PD	TRIP-OUT	2.75	POOH w/ 8 1/2" drilling BHA
746	PH	PE	HANDLE BHA	1.25	Hold JHA. P/U core barrels, M/U corehead (CD73) and load inner barrels as directed by DBS.
746	PH	PE	TRIP-IN	3.25	RIH w/ coring assembly to 744m.
746	PH	PE	CIRCULATE & CONDITION	0.75	Circulate bottoms up. Drop ball. Take SCR.
762	PH	PE	CORING	2.00	Cut core #1 f/ 746m to 762.3m.
762	PH	PE	TRIP-OUT	4.50	Flow check. POOH at controlled rate.
762	PH	PE	CORING	0.25	Test core for sour gas
762	PH	PE	CORING	0.75	Pull inner barrels and lay out w/ core bridles. 100% recovery.
762	PH	PE	HANDLE BHA	0.50	Check core head, OK. Clear two blocked nozzles.
762	PH	PE	TRIP-IN	2.25	M/U core barrel and RIH to 757m
762	PH	PE	CIRCULATE & CONDITION	1.00	Circulate bottoms up. Drop ball and observe pressure increase to 75psi. Take SCR.
780	PH	PE	CORING	1.00	Cut core #2 f/ 762.3m to 780.3m
780	PH	PE	TRIP-OUT	3.75	Flow check. POOH w/ core #2 at controlled rate.

Date : 16/10/99

Depth	Phase	Class	Operation	Hrs	Activity
780	PH	PE	TRIP-OUT	0.75	POOH w/ core #2 at controlled rate.
780	PH	PE	CORING	1.25	Hold JHA. L/D Core #2, 88% recovery.
780	PH	PE	HANDLE BHA	0.75	L/D core barrels.
780	PH	PD	TRIP-IN	3.00	P/U 8 1/2" packed drilling BHA and RIH
780	PH	PD	REAMWASH	1.50	Stabilisers hanging up in float and shoe. Work through and wash to bottom.
895	PH	PD	DRILLING AHEAD	6.00	Drill 8 1/2" hole f/ 780m to 895m (TD).
895	PH	PD	CIRCULATE & CONDITION	0.75	Circulate hole clean. Flow Check
895	PH	PD	TRIP-OUT	2.00	POOH to 688m. Flow check and pump slug. POOH to shoe, hole in good condition.
895	PH	PD	TRIP-OUT	1.00	Flow check and POOH to log.
895	E4	PE	HANDLE BHA	0.50	Hold JHA. R/U Schlumberger.
895	E4	PE	LOGGING	0.75	P/U PEX/DSI. RIH, loggers TD 890.5m.
895	E4	PE	LOGGING	2.50	Logging run #1 (PEX/HALS/DSI/NGS).
895	E4	PE	HANDLE TOOLS	1.25	L/D PEX/DSI. P/U FMI.
895	E4	PE	LOGGING	1.25	Logging Run #2 (FMI/GR).
895	E4	PE	HANDLE TOOLS	0.75	L/D FMI tool.

Date : 17/10/99

Depth	Phase	Class	Operation	Hrs	Activity
895	E4	PE	HANDLE TOOLS	3.50	M/U MDT toolstring and function test at surface.
895	E4	PE	LOGGING	6.00	RIH w/ MDT and record pressure data. Unable to take water/gas samples from Gurnard formation
895	E4	PE	HANDLE TOOLS	1.00	L/D MDT and service tool.

WELL :BALEEN #2

Date : 17/10/99

Depth	Phase	Class	Operation	Hrs	Activity
895	E4	PE	HANDLE TOOLS	0.50	P/U CSAT/GR
895	E4	PE	LOGGING	6.25	RIH w/ CSAT and record VSP data.
895	E4	PE	HANDLE TOOLS	0.25	L/D CSAT
895	E4	TE	HANDLE TOOLS	0.75	P/U Schlumberger MDT.
895	E4	TE	LOGGING	2.00	RIH w/ MDT. Attempt to obtain formation fluid samples, no success. POOH.
895	E4	TE	HANDLE TOOLS	2.75	Clean out MDT tool (sand) and add 6 gallon sample chamber.
895	E4	TE	LOGGING	1.00	RIH w/ MDT. Attempt to obtain formation fluid samples (Gurnard Gas/Water). Formation collapsing and tool flooding w/ sand.

Date : 18/10/99

Depth	Phase	Class	Operation	Hrs	Activity
895	E4	TE	LOGGING	0.50	Continue w/ logging run #6 (MDT/GR), no success.
895	E4	TE	HANDLE TOOLS	0.75	L/D MDT toolstring.
895	E4	TE	WAIT ON OTHER	1.25	Evaluate options.
895	E4	PE	HANDLE TOOLS	0.25	R/D Schlumberger
895	ABN	PA	PIPE - PICKUP	2.00	Hold JHA. P/U 20 jts 2 7/8" tubing as cement stinger.
895	ABN	PA	TRIP-IN	1.50	RIH w/ cement stinger to 890m.
895	ABN	PA	CIRCULATE & CONDITION	0.50	Circulate bottoms up. Hold cementing JHA.
895	ABN	PA	CEMENT ABANDONMENT/I	0.50	Pressure test lines to 2000psi. Pump plug #1 f/ 890m to 790m w/ 128sx neat "G" at 15.8ppg.
895	ABN	PA	TRIP-OUT	0.75	POOH to 760m.
895	ABN	PA	CIRCULATE & CONDITION	0.50	Circulate bottoms up.
895	ABN	PA	CEMENT ABANDONMENT/I	1.00	Set balanced plug #2 f/ 760m to 600m w/ 217sx "G" neat at 15.8ppg.
895	ABN	PA	TRIP-OUT	1.00	POOH to 550m.
895	ABN	PA	CIRCULATE & CONDITION	0.75	Circulate bottoms up. Function annular BOP.
895	ABN	PA	TRIP-OUT	0.75	POOH w/ drill pipe.
895	ABN	PA	PIPE - LAY DOWN	1.75	Hold JHA. L/O 2 7/8" cement stinger.
895	ABN	PA	PIPE - LAY DOWN	2.25	RIH w/ 6 1/4" drill collars. Hold JHA. L/O drill collars
895	ABN	PA	TRIP-IN	1.75	M/U muleshoe on drillpipe. RIH and tag TOC at 580m
895	ABN	PA	CIRCULATE & CONDITION	0.25	Circulate hole to inhibited mud.
895	ABN	PA	TRIP-OUT	0.75	POOH w/ drillpipe.
895	ABN	PA	RUN & SET PACKERS	2.75	R/U schlumberger. M/U gauge ring & junk basket. Run 8.5" gauge ring to 190m. POOH, L/D tool. Raise radio silence permit. M/U 9 5/8" EZSV bridge plug. Set bridge plug at 180m. POOH, R/D schlumberger.
895	ABN	PA	TRIP-IN	0.50	RIH w/ 5" drillpipe. Tag EZSV at 180m. P/U to 175m.
895	ABN	PA	CIRCULATE & CONDITION	0.50	Circulate hole to seawater. Flush kill and choke lines. Hold cementing JHA.
895	ABN	PA	CEMENT ABANDONMENT/I	0.75	Pressure test cement line to 2000psi. Pump plug #3 f/ 175m to 125m w/ 50sx neat "G" at 15.8ppg. Rig down lines.
895	ABN	PA	CIRCULATE & CONDITION	0.50	P/U to 150m and space out in BOP stack. Reverse circulate access cement until clean returns.
895	ABN	PA	TRIP-OUT	0.25	POOH 1 stand, circulate out.

Date : 19/10/99

Depth	Phase	Class	Operation	Hrs	Activity
895	ABN	PA	TRIP-OUT	0.25	Continue POOH w/ open ended Dp
895	ABN	PA	WELL-HEAD	2.00	RIH and retrieve flex joint and wellhead wearbushing. M/U jetting sub.
895	ABN	PA	BOP : NIPPLE U/D AND TES	0.50	Rig up to pull divertor and BOP.
895	ABN	PA	BOP : NIPPLE U/D AND TES	1.25	Hold JHA. M/U divertor r/tool, lay out divertor.
895	ABN	PA	BOP : NIPPLE U/D AND TES	1.25	M/U landing joint, close inner barrel and lock slip joint.
895	ABN	PA	BOP : NIPPLE U/D AND TES	0.50	Unlatch from wellhead connector, pull BOP. Hold JHA. Retrieve ruckers.
895	ABN	PA	BOP : NIPPLE U/D AND TES	4.25	Continue to pull BOP.

Date : 19/10/99

Depth	Phase	Class	Operation	Hrs	Activity
895	ABN	PA	BOP : NIPPLE U/D AND TEST	1.00	BOP on beams. jet stack and rack back LMRP and BOP.
895	ABN	PA	HANDLE BHA	1.00	M/U casing cutter w/ MOST tool and test same.
895	ABN	PA	TRIP-IN	1.00	RIH w/ casing cutter, attach guide wires. Land out MOST tool on wellhead and test latch, OK.
895	ABN	PA	CASING - CUT	3.25	Cut 20" and 30" casing at 84m.
895	ABN	PA	WELL-HEAD	0.25	Engage MOST tool and pull free w/ 15K. POOH w/ wellhead, housing and PGB. Set on beams.
895	ABN	PA	ANCHOR HANDLING	7.00	Commence anchor handling. Last anchor bolstered at 23:30 hrs 19/10/99. Rig released from Baleen 2.

908058 049

2.4. Non Productive Time Analysis

Total lost or non-productive time on Baleen 2 was 10.5 hrs.

0.5 hrs was lost waiting on cement. On completion of the 30" conductor cementation 6.25 hrs were spent WOC (planned), L/D BHA & landing strings, M/U drill out assemblies and performing a emergency winch off drill. Prior to drilling out a further 0.5 hrs WOC was required for the surface samples to set.

0.5 hrs was lost repairing the RPM sensor on the topdrive.

9 hrs were lost re-running the MDT in attempt to take gas samples from the Gurnard formation. During the first MDT run the pad seal was continuously lost, possibly as a result a combination of high draw-downs and friable formation. The MDT was configured with a standard sample probe for the re-runs, but on both occasions the MDT was flooded with sand.

TIME BREAKDOWN DATABASE Trouble Time Analysis

Well Name : BALEEN #2
 Drilling Co : Sedco Forex
 Rig : 702
 Spud Date : 10/10/99

Total Time on Well 227.50
 Total Trouble Time 10.50
 % Trouble Time 4.62

Total NPT Hours per Phase

PHASE	NPT HOURS
E4	9.00
IH1	1.00
PH	0.50

NPT On Well

PHASE	OPERATION	NPT Hrs	DEPTH	DESCRIPTION OF TROUBLE TIME
IH1	WAIT ON CEMENT	0.50	126.0	Wait on Cement
IH1	RIG REPAIR	0.50	126.0	Repair Geoservices RPM sensor. Service TDS and travelling block.
PH	DRILL FLOAT & SHOE TRACK	0.50	650.0	Drill out cement f/ 596m.
E4	HANDLE TOOLS	0.75	895.0	P/U Schlumberger MDT.
E4	LOGGING	2.00	895.0	RIH w/ MDT. Attempt to obtain formation fluid samples, no success. POOH.
E4	HANDLE TOOLS	2.75	895.0	Clean out MDT tool (sand) and add 6 gallon sample chamber.
E4	LOGGING	1.00	895.0	RIH w/ MDT. Attempt to obtain formation fluid samples (Gurnard Gas/Water). Formation collapsing and tool flooding w/ sand.
E4	LOGGING	0.50	895.0	Continue w/ logging run #6 (MDT/GR), no success.
E4	HANDLE TOOLS	0.75	895.0	L/D MDT toolstring.
E4	WAIT ON OTHER	1.25	895.0	Evaluate options.

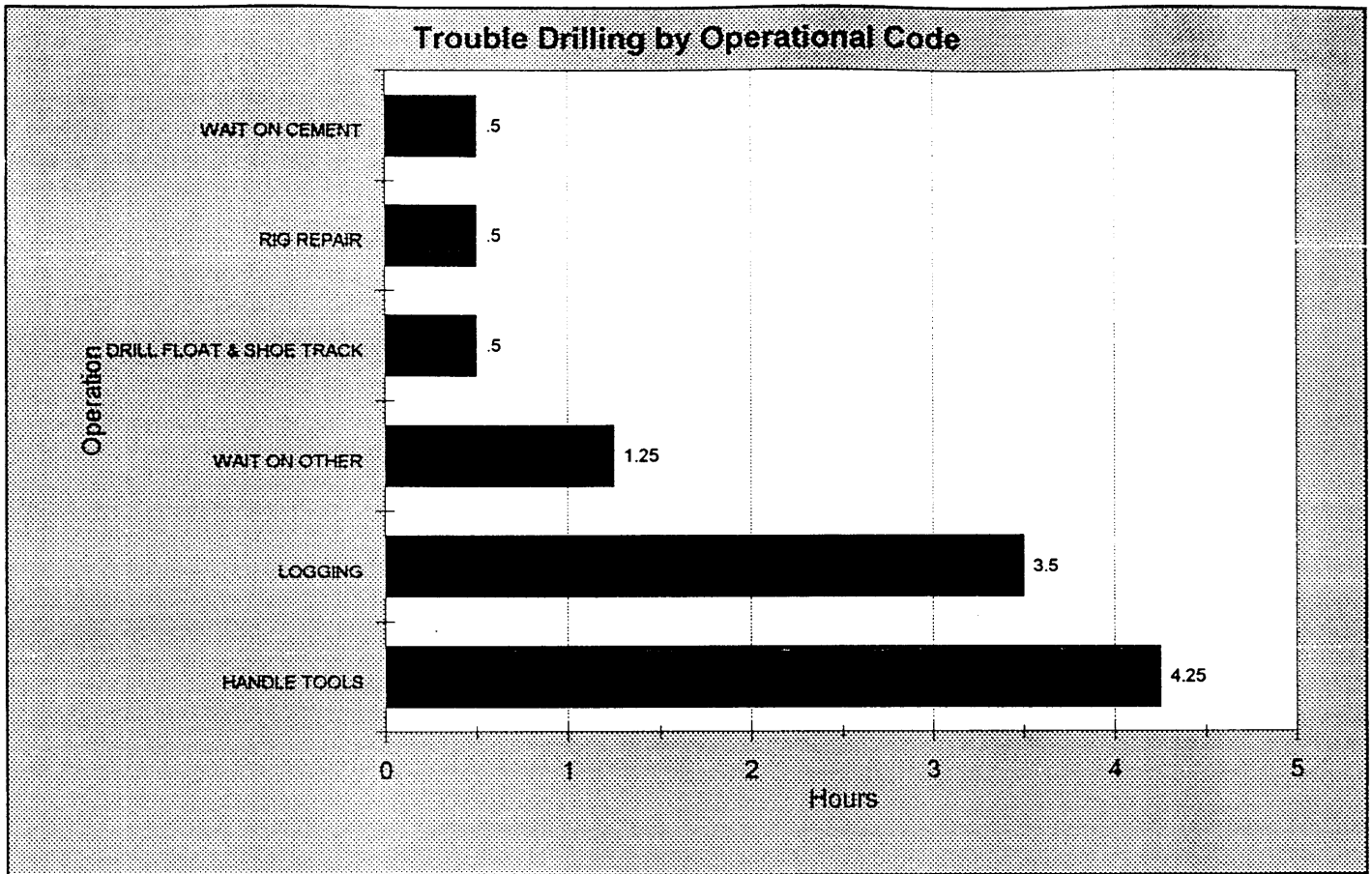

Trouble Drilling by Operational Code

OPERATION	NPT
HANDLE TOOLS	4.25
LOGGING	3.50
WAIT ON OTHER	1.25
DRILL FLOAT & SHOE TRAC	0.50
RIG REPAIR	0.50
WAIT ON CEMENT	0.50

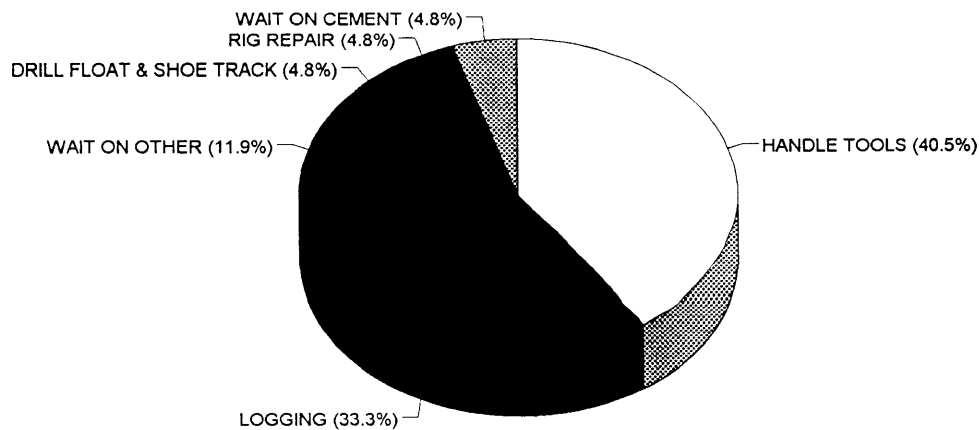

Time Breakdown by Phase
BALEEN #2

TOTAL HRS ON WELL :	0.00
TOTAL PROGRAMMED HRS :	0.00
TOTAL TROUBLE HRS :	10.50
TOTAL UNPROGRAMMED HRS :	0.00

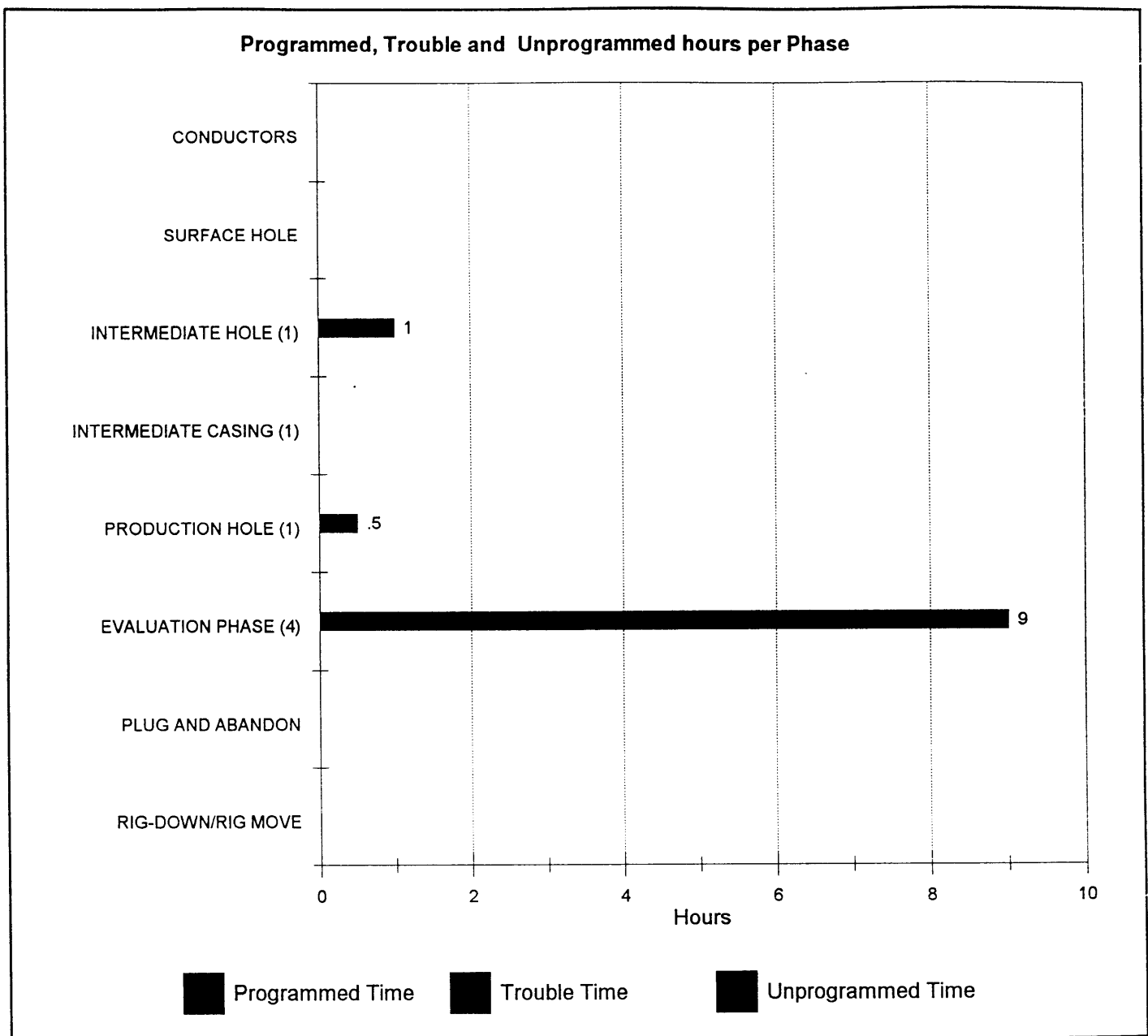

CODE	PHASE	PROG	TROUB	UNPROG
CON	CONDUCTORS			
SH	SURFACE HOLE			
IH1	INTERMEDIATE HOLE (1)		1.00	
IC1	INTERMEDIATE CASING (1)			
PH	PRODUCTION HOLE (1)		0.50	
E4	EVALUATION PHASE (4)		9.00	
ABN	PLUG AND ABANDON			
RMO	RIG-DOWN/RIG MOVE			

Revision 0 March 1999

Chart 1.1: Australasia semi-sub & drillship exploration and appraisal wells*

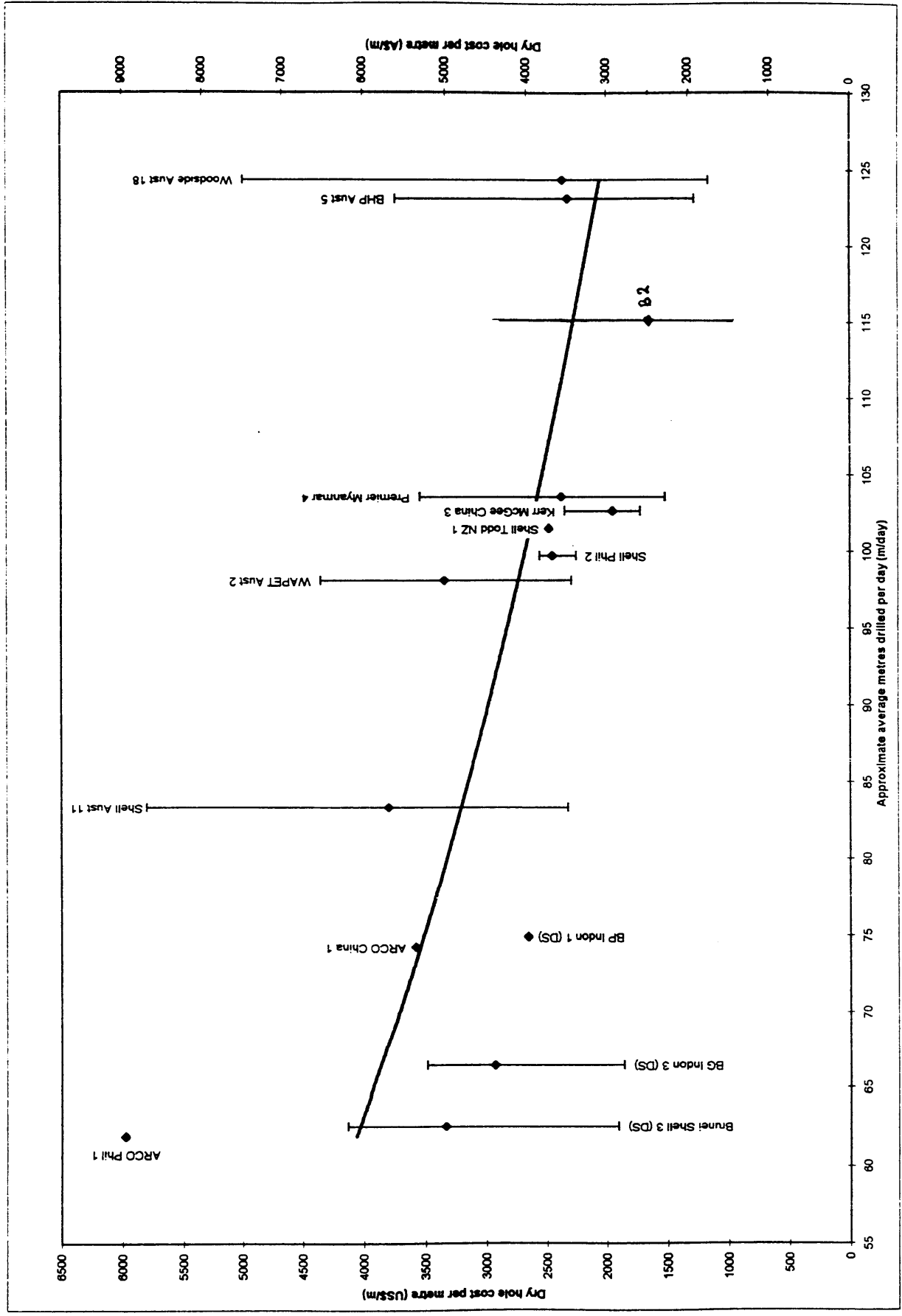

*Excludes slot recovery, sidetrack, high pressure and multilateral wells. (DS) - Drill ship wells
 Confidential. Produced by Rushmore Associates and Sigma Consultancy for the participants of the Australasia Drilling Performance Review for wells constructed in 1988

Chart 1.2: Australasia semi-sub & drillship exploration and appraisal wells*

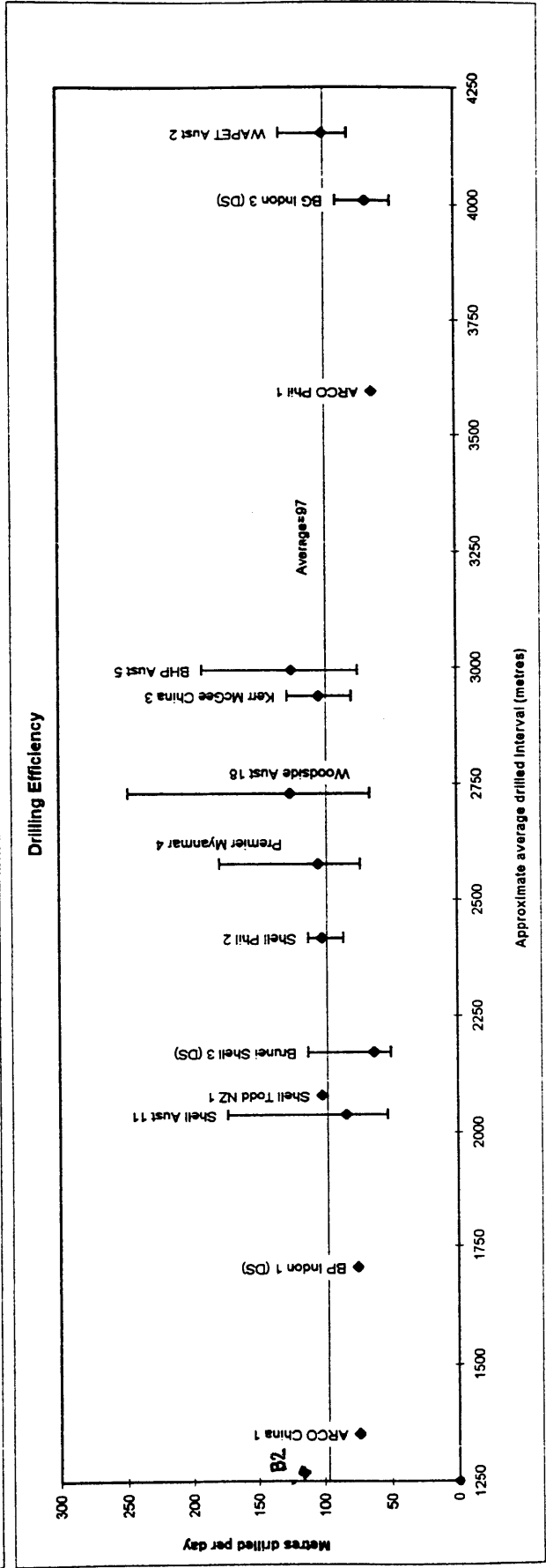
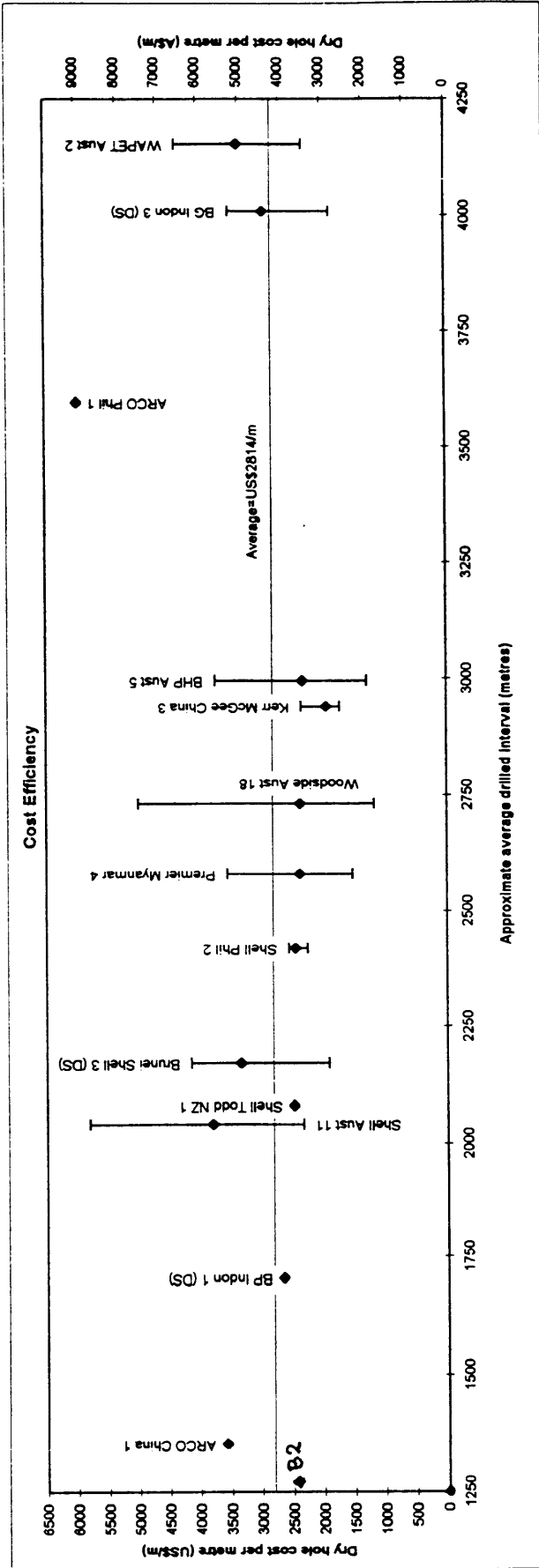

*Excludes slot recovery, sidetrack, high pressure and multilateral wells. (DS) - Drill ship wells
Confidential. Produced by Rushmore Associates and Sigma Consultancy for the participants of the Australasia Drilling Performance Review for wells constructed in 1998

WELL AFE - COST TRACKING - PRELIMINARY RUSHMORE DATA

Well: Patricia - Baleen
 Area: VIC RL-5
 Permit: VERTICAL APPRAISAL WELL
 Country: Australia
 AFE No: 99-RL5-01

	Cost Tracking day 11	Pre-Well Cost	Abandon Cost	Rushmore Cost
SITE SURVEY AND POSITIONING	\$7,940	\$7,940	\$0	\$0
EQUIPMENT TRANSPORT AND MOB/DEMOB	\$0	\$0	\$0	\$0
TRAVEL AND ACCOMMODATION	\$56,500	\$19,600	\$8,200	\$28,700
HELICOPTERS	\$107,298	\$35,064	\$16,052	\$56,182
SUPPLY VESSELS	\$495,300	\$152,400	\$76,200	\$266,700
WHARFAGE AND STEVEDORING	\$30,000	\$10,000	\$5,000	\$15,000
METEOROLOGICAL / OCEANOGRAPHIC	\$1,534	\$472	\$236	\$826
DIVING	\$53,769	\$15,692	\$8,462	\$29,615
CONTRACT RIG	\$1,953,846	\$409,231	\$830,769	\$753,846
CONTRACT CATERING	\$13,000	\$4,000	\$2,000	\$7,000
MUD ENGINEERING AND MATERIALS	\$83,154	\$33,310	\$1,300	\$48,545
CEMENTING SERVICES AND EQUIPMENT	\$94,332	\$16,384	\$13,287	\$64,662
WELL TESTING	\$0	\$0	\$0	\$0
CORING	\$61,815	\$0	\$0	\$61,815
MUD LOGGING	\$30,075	\$3,075	\$6,000	\$21,000
DIRECTIONAL DRILLING	\$19,298	\$7,945	\$2,523	\$8,831
ELECTRIC WIRELINE LOGGING	\$178,922	\$0	\$0	\$178,922
CASING, LINER AND ACCESSORIES	\$121,912	\$12,479	\$10,118	\$99,315
COMPLETION EQUIPMENT	\$0	\$0	\$0	\$0
COMMUNICATIONS	\$7,345	\$2,260	\$1,130	\$3,955
DRILLING BITS	\$64,940	\$7,720	\$50	\$57,170
DOWNHOLE TOOL RENTAL	\$55,662	\$6,769	\$37,446	\$11,446
WELLHEAD & SS TREE	\$142,550	\$6,585	\$0	\$135,965
CONSULTANTS	\$162,860	\$82,085	\$17,950	\$62,825
TIME WRITING	\$52,500	\$25,500	\$6,000	\$21,000
FUEL AND LUBES	\$158,671	\$80,943	\$18,080	\$59,648
INSURANCE, ACCOUNTING & LEGAL	\$0	\$0	\$0	\$0
ENVIRONMENTAL AND SAFETY	\$16,000	\$16,000	\$0	\$0
ANALYTICAL SERVICES - NOT INCLUDED	\$0	\$0	\$0	\$0
DRAFTING AND CONSUMABLES	\$19,000	\$10,000	\$2,000	\$7,000
OTHERS	\$3,900	\$1,200	\$600	\$2,100
TOTAL WELL COSTS	\$3,992,123	\$966,653	\$1,063,403	\$1,962,067
Drilled Interval (MTD - Spud depth)	814 m			
Dryhole Cost (excl. Mob/move/planning/abandon)	\$1,962,067 AUD			
Total Dry Hole Days (from spud to start abandon)	168.75 hrs			
Cost Efficiency	\$2,410.40 AUD/m			
Drilling Efficiency	116 m/day			

Rushmore
ASSOCIATES

5th Annual Australasia Drilling Performance Review

Wells drilled in 1998

Revision 0. March 1999

Confidential. Restricted solely to the participant companies listed overleaf.

the **sigma** consultancy (scotland) ltd

Index

<u>Page</u>	<u>Contents</u>
i	Revision status
ii	Main index
iii	List of participants
iv	The charts – explanatory details and confidentiality of the data
v	Declarations of full data submission and notes on the time / depth charts
vi	Contact details
xi	Definitions and instructions for completion of the spreadsheet
xix	Index of charts
1	Headline charts
9	Category charts
19	Distribution charts
47	Database charts
66	Time / Depth and well path charts

Participants

Amerada Hess Thailand
Apache Australia
Apache China
ARCO China
ARCO Philippines
BG Indonesia
BHP Australia
BP Indonesia
Chevron China
Chevron Papua New Guinea
Cultus Australia
Elf Brunei
Fina Vietnam
Fletcher Challenge Brunei
Kerr McGee China
Mobil Australia
OMV Pakistan
Premier Indonesia
Premier Myanmar
Premier Pakistan
Shell Australia
Shell Brunei
Shell Philippines
Shell-Todd New Zealand
Victoria Petroleum Australia
WAPET Australia
Woodside Australia

The charts – explanatory details

Most of the charts show the mean value of the data set plotted as a diamond shape and, where relevant, the range of the data set as two bars - the upper being the maximum value of any one well, the lower being the minimum value of any one well.

Each data set is labelled with the name of the Operator and the number of wells contained in that data set. Where one outlying value would cause an inappropriate axis scale to be used we have marked that value within a box on the chart rather than extend the axis scale to capture it.

The trend lines have been added automatically by Excel. We have only included trend and average lines when it seems to us that it is reasonably valid to do so.

The '6 series' charts show individual wells plotted as a diamond shape and plot both dry hole days and dry hole costs for individual wells against drilled interval allowing a view of the distribution of an Operators wells against the background of the industry trend line.

This year, for land wells, the industry data did not support the drawing of a trend line so an 'envelope' of the range of data has been provided instead.

The printed database excludes one or two columns dealing with accounting currency and exchange rates and may exclude part of any longer entries in the comments column. The full database is contained on the CD.

Where we have plotted Australian and Asian wells together on the same charts we have used US \$ on the left hand axis and A \$ on the right hand axis using US \$1 = A \$1.5.

We can provide charts with different axis scales or indeed any other charts at all upon request.

The charts – validity and meaning

Cost information should be treated with caution as not all Operators allocate costs in the same way and differing accounting practices easily cause variations of + / - 15% in reported dry hole costs.

For the Asia charts some Operators reported in US dollars and some in local currency with an exchange rate to US dollars. The details are given on the full database. For this reason caution should also be exercised with the Asia cost information provided.

It is important to note that the charts only really provide 'clues' or 'indicators' to real comparative performance. It is necessary to understand the well objectives, conditions and constraints under which these wells are drilled before any meaningful conclusions can be drawn from the data provided here.

Confidentiality of the data

The data is not available for sale or supply to any third party by Rushmore Associates and the Sigma Consultancy.

Rushmore Associates and the Sigma Consultancy, their employees and associates, keep all well data confidential and do not supply any well data to any party other than the participants of the Review for the year in question.

It is a condition of participation that Operators agree to keep the Review confidential within their organisation.

It is acceptable for an Operator to provide a copy of the Review to its Head Office and to non-operating Partners or non-operating Joint Venturer's where necessary as part of an operating agreement

It is a condition of participation that the well data within the Review should not be provided by Participants to either other Operators or to other operating units of their company that would have qualified to participate in the Review in Australasia but did not.

For marketing purposes, Rushmore Associates may freely publicise the Review in general terms including the identity of participants, the scope, general content and format.

Declaration of full data submission

Participation is open only to Operators who agree to supply data on all of their wells for the year in question in their area of Operation.

It is permissible for Operators to withhold data on genuinely 'tight' wells. In this case it is expected that the tight wells will constitute only a small part of an Operators submission. The well names and locations of tight wells should be given but all other data may be withheld.

All participants have declared that they have submitted all their offshore and land wells constructed in 1998 except for Premier Pakistan who did not submit Zamzama 1 Dadu which they drilled for BHP and which BHP consider as tight.

Time / Depth charts

There are a few TD charts missing from some Operators including Apache Australia, Apache China, Fina Vietnam and WAPET either because they were not drawn or cannot be found.

If you would like a copy of any of these please contact the relevant Operator directly.

TD charts are provided on the CD in Adobe Acrobat (.pdf) format. An Acrobat Reader program is supplied with the CD allowing file viewing and printing.

Definitions and instructions for data input

Note: the definitions and instructions given below are those that we provided to the participants along with the data input spreadsheet.

The final database / spreadsheet included with the Review contains additional columns so the original column numbering below will not be valid for it.

We have also added some calculated data to the final database / spreadsheet;

Drilled interval	MTD – spud depth
Cost efficiency (cost per metre)	Dry hole cost / drilled interval
Drilling efficiency (metres per day)	Drilled interval / dry hole days
Complexity ratio	MTD / TVD
Aspect ratio	Horizontal displacement / TVD * indicates complex well path

Which wells need to be entered onto this spreadsheet?

All of the wells, both land and offshore, drilled by your company that were finished, i.e., the rig was released or available to start other work, during the calendar year 1998.

This will include wells spudded during 1997 if they were not finished until 1998.

Declaration

Please complete this box to indicate whether you have submitted all your 1998 wells or not.

If you have withheld any wells you must give their names here and the reason for withholding.

It is permitted to withhold wells only if they are genuinely 'tight' or some other 'force majeure' situation, such as change of ownership, has occurred. It is not permitted to participate in the Review and withhold wells based on their perceived suitability for inclusion in comparative benchmarking studies or similar reasons.

Please enter the name of the person making the declaration – usually the Drilling Manager or equivalent.

Contact details	These will be published in the Review for the purpose of identifying one individual in your company whom participants may contact in the first instance if they have any questions or queries about your wells or data.
Time – depth charts	<p>A time – depth chart for each of your wells needs to be submitted with the spreadsheet. Please do not include more than one well on any chart except that geological sidetracks and multi-lateral branches may be shown on the same chart as their parent well.</p> <p>TD charts can be submitted on hard copy (A4 and good quality please) or electronically in MS Excel or PowerPoint.</p> <p>Do not include any confidential information on the TD chart but annotated charts are much more useful to all participants than plain lines.</p> <p>Please include both planned and actual curves.</p>
Column 1 – Well name	<p>Enter the names of all of your wells. Please use standard or official naming conventions where possible, rather than just the 'in house' short version.</p> <p>Slot Recovery wells, Geological Sidetrack's and Multi-Lateral Branches (defined in column 7 below) are regarded as separate from their 'parent' well, and must therefore be given a separate row on the spreadsheet.</p>
Column 2 – Country	<p>Enter the name of the country here</p> <p>or, for Australia and New Zealand enter the code for the basin as given below;</p> <p>1 for wells located in the Bonaparte basin, including the Timor Sea and Zone of Co-operation, 2 - Browse, 3 - Canning, 4 – Camarvon, 5 – Perth, 6 – Duntroon, 7 - Otway, 8 - Bass, 9 - Gippsland, 10 - Taranaki (NZ), 11 - any other Australian / NZ offshore location not given above, 12 - Australian land wells not located in any of the basins noted above 13 – New Zealand land wells</p>
Column 3 – Field, block or platform name	Enter the field, block or platform name if it not already part of the well name
Column 4 - Geographical latitude	Enter the well's latitude (North or South) in degrees, minutes and seconds – <u>not its grid coordinates in metres.</u>

**Column 5 -
Geographical longitude**

Enter the well's longitude (East or West) in degrees, minutes and seconds - not its grid coordinates in metres.

Do not give any more detail than this, no parts of a second are required.

Column 6 – Spud date

Date (mm/yy format) of spud as defined below.

Column 7 – Hole type

**New well
Geological sidetrack
Multi-lateral parent well
Multi-lateral branch
Slot recovery well**

A new well 'N' is defined as a well planned and drilled as a single bore (ignoring technical sidetracks) from the spud point at seabed or bottom of cellar to its TD.

Note that unplanned 'technical' sidetracks due to problems such as stuck pipe, lost hole, twist off's etc. are considered as part of the new well and their time and cost are included in the new well data. Additional footage caused by technical sidetracks is not recorded.

A geological sidetrack well 'G' is a well planned and drilled from the bore of another well (which has not been used for producing or injecting) in order to achieve a geological objective.

Again, unplanned 'technical' sidetracks due to problems such as stuck pipe, lost hole, twist off's etc. may be required during drilling of the geological sidetrack and, if so, are considered as part of the geological sidetrack and their time and cost are included in it. Additional footage caused by technical sidetracks is not recorded.

Slot recovery wells 'S' are new wells kicking off from some point in the bore of a previously used (either producing or injecting) well.

A multi-lateral parent well 'P' is defined as a well from which multi-lateral branches are extended. The parent well may be drilled to determine the exact location of a geological feature and then plugged back in order to drill a multi-lateral branch(s), or may be completed as a producer.

A multi-lateral branch completed as an open hole should be marked 'MO'. A multi-lateral well branch completed as cased hole should be marked 'MC'.

Column 8 – Well type

Exploration 'E', Appraisal 'A' and Development 'D'.

Column 9 – High pressure wells

Mark this column 'HP' for wells greater than 10,000 psi pore pressure

Column 10 – Rig type	Land 'LA', Semi-Submersible 'SS', Jack-up 'JK', Platform 'PL', Platform Tender-Assisted 'TA', Drillship 'DS', Barge 'BA', Heli-rig 'HR' and Submersible 'SU'.
Column 11 – Spud depth in metres	<p>Depth of the spud point below the rotary table.</p> <p>For new offshore wells the spud point will be at the sea bed. For new land wells at the bottom of the cellar.</p> <p>For slot recovery wells, spud is taken as the first new hole outside of the milled-out window – measured along the well bore, not the true vertical depth.</p> <p>For multi-lateral branches and geological sidetracks spud is taken at the junction between the branch or sidetrack and the parent well - measured along the well bore, not the true vertical depth.</p>
Column 12 - MTD metres	Measured depth from rotary table to end of well (TD) along the well bore.
Column 13 - TVD metres	True vertical depth from the rotary table to end of well (TD).
Column 14 – Horizontal displacement from the <u>spud point</u> to TD in metres (for geological sidetrack, slot recovery well and multi-lateral branches <u>only</u>)	<p>Distance in the horizontal plane from the spud point to the end of well (TD).</p> <p>For slot recovery wells, geological sidetracks and multi-lateral branches the spud location may be some distance from the rotary table in the horizontal plane.</p>
Column 15 – Horizontal displacement from the <u>rotary table</u> to TD in metres (for new and multi-lateral parent wells <u>only</u>)	<p>Distance in the horizontal plane from the rotary table to the end of well (TD).</p> <p>For highly complex wells where the horizontal displacement of TD is not meaningful, place a 'D' in this column and include a well trajectory diagram with your submission.</p>
Column 16 - Maximum angle in degrees	<p>The maximum angle of any hole section in the well.</p> <p>A well with a maximum angle of 85 degrees or greater will be categorised as a horizontal well in this Review.</p>
Column 17 - Total length of horizontal sections in metres	The total length of sections of the well with an angle of 85 degrees or greater.

Column 18 - Pre-existing casing strings.

Record the size of conductor and casing strings that were in place before the start of continuous drilling operations and above the spud point.

For example, in a Geological Sidetrack well where the sidetrack was made out of the 9-5/8" casing, the pre-existing casing string might be '26.5 18.625 13.375 9.625'.

Alternatively, for example, the 30 inch and 20 inch may have been pre-set by one rig, and the well later drilled out to TD by another. You would enter '30 20' in this column.

Report casing sizes in decimal, leaving a space between each size. Do not use comma's or any other symbol.

If you have 'combination strings' report them with an oblique - e.g., '30 26 13.375 10.25/9.625 7/5.5'. In this example two combination strings; 10.25/9.625 and 7/5.5 have been run.

Do not show the same size casing in both this column and the next one.

For new land wells show all casing in the next column.

Column 19 - New casing strings and drilling liners

Record the size of conductor, casing and drilling liners used in the construction of the well below any pre-existing strings.

Reporting format as detailed above.

Do not record the same casing in both this and the preceding column – any one casing will belong in one of these columns but not in both.

Column 20 – Completion liner size

Although the completion phase is outside the scope of this study please record the completion liner size here.

The time and cost associated with running the completion liner is not included in any data collected below.

Column 21 – Mud type

Record all the mud type(s) used in the well.

'W' – WBM, 'O' - OBM, 'S' – Synthetic and 'E' – Ester.

Column 22 - Mud weight at TD	Record the Specific Gravity (sg) of mud at TD Do not report in lb./gallon or any other units.
Column 23 - Maximum mud weight	Record the maximum Specific Gravity (sg) of mud used at any point in the well. Do not report in lb./gallon or any other units.
Column 24 - Coring days	Number of days spent coring the well in any hole section, reported in decimal e.g., '0.9'. Coring starts with circulation prior to POOH to core, and ends just after drilling out the core rat hole.
Column 25 - Coring interval metres	Length of well bore cored. Please report the cumulative length – not the start and finish depths.
Column 26 - Logging days at TD	Number of days spent logging, only after TD is reached. Please report in decimal e.g., '2.7'. This is the measure of the number of days spent log evaluating the pay zone. Time starts with circulation prior to POOH to log and ends either when starting last operation prior to running the production casing if wiper trip is not run, or after drillstring reaches TD if wiper trip is run.
Column 27 - Logging days not at TD	Number of days spent logging before TD is reached. Please report in decimal e.g., '2.7'.
Column 28 – Land rig move days	Where you are drilling a number of land wells in the same region and it would be useful to know rig move times please enter the number of days from start of rig down at the previous location to end of rig up at this location.
Column 29 – Land rig move distance	If you have entered a number in the preceding column enter here the number of kilometres from the previous location.
Column 30 - Total dry hole days	Number of days from spud until either start of abandonment or start of running test or production string. This includes days spent drilling narrow gauge 'shallow gas' holes, and technical sidetracking.

Column 31 - Waiting on weather during dry hole days	Report number of days spent waiting on weather during the dry hole days period - e.g., '1.7'
Column 32 - Days at well site, excluding C & T.	Total number of days from rig arrival on location until rig released from location, <u>but excluding completion and testing times.</u>
Column 33 - Well status	Record whether the well was Completed 'CO', Suspended 'SU', Abandoned 'AB', or Other 'O'. If 'other' please give details in comments column.
Column 34 - Dry hole cost	Cost of operations incurred during dry hole days in your accounting currency. This includes cost of narrow gauge 'shallow gas' holes and technical sidetracks. It includes cost of operations, overheads, incentive payments, logging, transport, materials supply and wellheads (except in re-entries). It excludes completion and well test operations, production strings / completion liners installed after TD logging, trees and completion equipment. It also excludes costs due to rig moves, site preparation, mobilisation / demobilisation, site survey, well design and programming, suspension, plug and abandonment etc.
Column 35 - Total well cost	This is the total cost of the well in your accounting currency including all the items specifically excluded from the dry hole cost. It therefore includes; <u>completion and well test operations</u> , suspension operations, plug and abandonment operations, production strings and liners installed after TD logging, trees and completion equipment, rig moves, site preparation and re-instatement, mobilisation / demobilisation, site survey, well design and programming, etc.
Column 36 – Accounting currency	Enter your accounting currency
Column 37 – Exchange rate to US dollars	In order to plot Asian wells together on the same charts we convert their costs to US dollars. If you have included Asian wells please give the exchange rate we should use to convert your accounting currency to US dollars.

Column 38 – Exchange rate to Australian dollars

If you would like your (non-Australian) wells plotted together with the Australian wells (perhaps if you drilled in NZ or PNG etc) please let us know and give the exchange rate we should use to convert your accounting currency to Australian dollars.

Column 39 – Comments

Events that have significantly affected either dry hole days, or dry hole costs should be noted in the comments column, with an indication, if possible, of the 'interruption time'. Please also note any other significant information.

Please restrict your comments to 60 characters.

Please use abbreviations as shown;

ST – technical sidetrack

SP - stuck pipe

EP – equipment problems

PH - pilot hole

TO - twist off

IT – interruption time / down time / trouble time etc.

D – days

SC – scope change

PC – platform constraints

for example; ST & EP 6.4 D.

Index to ChartsHeadline charts

<u>Page</u>	<u>Chart</u>	<u>Title</u>
1	1.1	Australasia semi-sub and drillship E&A wells. Cost/metre vs. metres/day
2	1.2	Australasia semi-sub and drillship E&A wells. Cost/metre and metres/day vs. drilled interval
3	2.1	Australasia jack-up and barge E&A wells. Cost/metre vs. metres/day
4	2.2	Australasia jack-up and barge E&A wells. Cost/metre and metres/day vs. drilled interval
5	3.1	Australasia offshore development wells. Cost/metre vs. metres/day
6	3.2	Australasia offshore development wells. Cost/metre and metres/day vs. drilled interval
7	4.1	Australasia land wells. Cost/metre vs. metres/day
8	4.2	Australasia land wells Cost/metre and metres/day vs. drilled interval

Category charts

All category charts contain four graphs;

Cost/metre vs. drilled interval
Metres/day vs. drilled interval
Cost/metre vs. metres/day
Coring and logging times

9	5.1	Category 1 Australia Camarvon basin Offshore E&A wells.
10	5.2	Category 2 Australia and New Zealand except Camarvon basin semi-sub E&A wells
11	5.3	Category 3 Australia and New Zealand Offshore development wells
12	5.4	Category 4 Australia and New Zealand

- Land wells
- 13 5.5 Category 5
Australia and New Zealand
Slot recovery, geological sidetrack and multilateral wells
 - 14 5.6 Category 6
Asia
semi-sub and drillship E&A wells
 - 15 5.7 Category 7
Asia
Jack-up and barge E&A wells
 - 16 5.8 Category 8
Asia
Offshore development wells
 - 17 5.9 Category 9
Asia
Land wells
 - 18 5.10 Category 10
Asia
Geological sidetrack and HP wells

Distribution charts

The first graph in each of the charts below show all Operators wells and an 'industry' trend line. The remaining graphs show each Operators wells individually against a background of the industry trend line.

For the land wells the 'industry' data did not support the drawing of a trend line so an 'envelope' of the range of data has been provided instead.

- 19 6.1 Australasia
Distribution of dry hole DAYS for offshore E&A wells
- 26 6.2 Australasia
Distribution of dry hole COST for offshore E&A wells
- 33 6.3 Australasia
Distribution of dry hole DAYS for offshore development wells
- 36 6.4 Australasia
Distribution of dry hole COST for offshore development wells
- 39 6.5 Australasia
Distribution of dry hole DAYS for land wells
- 43 6.6 Australasia
Distribution of dry hole COST for land wells

Database charts

47	7.1	Australia database by category
55	7.2	Asia database by category
61	7.3	Australia database by company
65	7.4	Asia database by company

903058 074

3. DRILLING DATA

908058 075

SEDCO 702

RIG DESCRIPTION
&
EQUIPMENT LIST

Sedco 702

TABLE OF CONTENTS

	Page
1.0 DRILLING VESSEL SPECIFICATION	8
1.1 Unit Specification.....	8
1.2 Major Dimensions.....	8
1.3 Storage Capacity.....	8
1.4 Detailed Variable Load.....	8
1.5 Operational Condition And Limits.....	9
2.0 THRUSTERS AND TOWING REQUIREMENT	10
2.1 Thrusters.....	10
2.2 Towing / Anchor Handling Requirement.....	10
3.0 MOORING EQUIPMENT	11
3.1 Standard Anchor Pattern.....	11
3.2 Anchor Line Specification.....	11
3.3 Anchor Winches / Windlasses.....	11
3.4 Mechanical Brakes.....	11
3.5 Dynamic Brakes.....	11
3.6 Fairlead.....	11
3.7 Primary Anchors.....	11
3.8 Spare Anchors (Piggyback).....	11
3.9 Pennant Lines.....	12
3.10 Anchor Buoys.....	12
3.11 Chain Chasers.....	12
3.12 Mooring Instrumentation.....	12
4.0 UNIT AUXILIARY EQUIPMENT	13
4.1 Living Quarters.....	13
4.2 Cranes.....	13
4.3 Helicopter Deck.....	13
4.4 Well Testing & Production Equipment.....	14
4.5 Electronic Testing Equipment.....	14
4.6 Utility Hoist.....	14
4.7 Other Equipment And Facilities.....	14
5.0 SPACE FOR THIRD PARTY EQUIPMENT	17
5.1 Cementing Unit.....	17
5.2 Mud Logging Unit.....	17
5.3 Electric Logging Unit.....	17
5.4 ROV Unit.....	17
5.5 Third Party Contractor Office.....	17
5.6 MWD Unit.....	17
6.0 POWER PLANT AND TRANSMISSION	18
6.1 DC Generator Set.....	18
6.2 AC Generator Set.....	18
6.3 Diesel Engines.....	18
6.4 SCR System.....	18
6.5 Transformer System.....	18
6.6 Distribution Centers.....	18
6.7 DC And AC Electric Motors Inventory.....	18

7.0	SAFETY EQUIPMENT	20
7.1	Survival Craft And Life Raft	20
7.2	Life Jackets	20
7.3	Life Buoys.....	20
7.4	Sick Bay	20
7.5	First Aid	20
7.6	Derrick Safety Equipment.....	21
7.7	Personnel Safety Apparel.....	21
7.8	Electrical Safety Equipment	21
7.9	Breathing Apparatus.....	21
7.10	Warning Signs	21
7.11	Emergency Equipment Boxes	21
7.12	Fireman's Outfit	21
7.13	Work Vests	21
7.14	Safety Guards And Exits	21
7.15	Safety Chains And Clamps	21
7.16	Spark Arrestors And Flashback Arrestors	21
7.17	Pollution Control System	21
7.18	Auxiliary Safety Equipment	22
8.0	EMERGENCY ELECTRICAL SYSTEM.....	23
8.1	Emergency Power Generator(s).....	23
8.4	Battery Powered Emergency System.....	23
9.0	H2S, COMBUSTIBLE, BLOWOUT AND FIRE DETECTION AND WARNING SYSTEM	24
9.1	Fixed Installations	24
9.2	Portable Instruments	24
10.0	FIRE EXTINGUISHING EQUIPMENT.....	25
10.1	FIXED CO2 System.....	25
10.2	Dry Chemical Units.....	25
10.3	Foam Unit.....	25
10.4	CO2 Units.....	25
10.5	Fire Pump.....	25
11.0	COMMUNICATION EQUIPMENT	26
11.1	Radio Equipment - GMDSS.....	26
11.2	Radio Equipment - VHF-FM Type	26
11.3	VHF Ground To Helicopter	26
11.4	Handheld Aeronautical VHF Radio	26
11.5	Radio Beacon Homing Device For Helicopter	26
11.6	Satellite Communication System (i.e. MARISAT).....	26
11.7	Interior Communication	26
12.0	NAVIGATION EQUIPMENT.....	27
12.1	Magnetic Compass.....	27
12.2	Navigational Aids.....	27
12.3	Radar Unit	27
13.0	DRILLING RIG SPECIFICATION	28
13.1	Derrick.....	28
13.2	Casing Stabbing Platform.....	28
13.3	Derrick Substructure.....	28
13.4	Crown Block	28
13.5	Travelling Block.....	28

13.6	Hook	28
13.7	Drilling Line.....	28
13.8	Sandline Size : 9 / 16"	29
13.9	Motion Compensator.....	29
13.10	Swivel	29
13.11	Deadline Anchor.....	29
13.12	Drawwork Assembly.....	29
13.13	Rotary Table.....	29
14.0	RIG FLOOR EQUIPMENT	30
14.1	Hydraulic Cathead (EZY Torque)	30
14.2	Kelly Spinner (Power Sub)	30
14.3	Spinning Wrench.....	30
14.4	Wireline Measuring Assembly (Slickline)	30
14.5	Hydraulic Testing Pump	30
14.6	Iron Roughneck.....	30
15.0	MUD CIRCULATION SYSTEM.....	31
15.1	Mud Pumps	31
15.2	Mud Pump Discharge Lines	31
15.3	Standpipe Manifold.....	31
15.4	Rotary Hoses.....	31
15.5	Cementing Hose.....	31
16.0	LIQUID MUD STORAGE	32
16.1	Mud Tanks.....	32
	* ASSUMES TANKS FILLED TO 8' LEVEL	32
17.0	MUD MIXING AND TREATMENT SYSTEM.....	33
17.1	Mud Mixing Pumps.....	33
17.2	Electrical Mud Mixers/Agitators	33
17.3	Bottom Guns	33
17.4	Mixing Hoppers	33
17.5	Mud Shearing Unit.....	33
17.6	Chemical Mixing Tank.....	33
17.7	Shale Shakers.....	33
17.8	Degasser	33
17.9	Desander.....	33
17.10	Desilter	33
17.11	Mud Cleaners	33
17.14	Mud Gas Separator	34
17.15	Trip Tank	34
18.0	DRY CEMENT AND MUD BULK STORAGE AND TRANSFER SYSTEM.....	35
18.1	P-Tank.....	35
18.2	Surge Tank For Cement.....	35
18.3	Surge Tank For Barite/ Bentonite.....	35
18.4	Transfer System	35
18.5	Supply Hoses	35
19.0	CEMENTING SYSTEM	36
19.1	Cementing Unit.....	36
19.2	Cementing Discharging Lines And Manifold	36
20.0	BLOWOUT PREVENTION SYSTEM.....	37

20.1	Spherical/Bag Type Preventer	37
20.2	Ram Type Preventer	37
20.3	Kill/Choke Valves	37
20.4	Pipe Rams Available	37
20.5	Connecting Line	37
20.6	BOP's Handling And Emergency Recovery System	37
20.7	Ball/Flex Joint	37
21.0	RISER AND ASSOCIATED EQUIPMENT	38
21.1	Marine Riser	38
21.2	Kill/Choke Lines Dimensions	38
21.3	Riser Joint	38
21.4	Riser Pup Joint	38
21.5	Riser Auto Fill Valve	38
21.6	Telescopic Joint	38
21.7	Diverter	38
21.8	Diverter Flex Joint	38
21.9	Diverter Lines	39
21.10	Marine Riser Spider And Handling Tools	39
21.11	Riser Tensioning System	39
21.12	Guide Line Tension System	39
22.0	BOP CONTROL SYSTEM AND ASSOCIATED EQUIPMENT	40
22.1	BOP Control System	40
22.2	Surface Accumulator Unit	40
22.3	Accumulator Bottles On BOP Stack	40
22.4	Triplex Pumps	40
22.5	Air Pumps	40
22.6	Central Control Unit	40
22.7	Driller's Control Panel	40
22.8	Remote Control Panel	40
22.9	Diverter Control Panel	41
22.10	Hoses, BOP Control Lines	41
22.11	Hose Reels	41
22.12	Control Pods	41
22.13	Test Stump	41
23.0	CHOKE MANIFOLD	42
23.1	Valves	42
23.2	Adjustable Choke (Manual)	42
23.3	Hydraulic Choke	42
23.4	Power Choke Remote Control Panel	42
23.5	Hoses	42
23.6	Chiksan Joints	42
23.7	Crossover To Test BOP Casing Pipe Rams	42
24.0	UNDERWATER AUXILIARY EQUIPMENT	43
24.1	Hole Position Indicator	43
24.2	Slope Indicator	43
24.3	Underwater Television	43
25.0	DRILLING EQUIPMENT	44
25.1	Top Drive	44
25.2	Kelly	44
25.3	Kelly Saver Sub	44

25.4	Kelly Test Sub	44
25.5	5" OD Drill Pipe	44
25.6	5" OD Drill Pipe Pup Joints.....	44
25.7	3-1/2" OD Drill Pipe	44
25.8	Drill Pipe Elevators	44
25.9	Drill Pipe Slips	44
25.10	Drill Pipe Power Slips	45
25.11	Drill Pipe Protectors.....	45
25.12	5" OD Hevi-wate Drill Pipe	45
25.13	Drill Collars	45
25.14	Drill Collar Elevator.....	45
25.15	Lifting Sub	45
25.16	Drill Collar Slips	45
25.17	Safety Clamps (Dog Collars).....	46
25.18	Drill Pipe And Drill Collar Rotary Tongs	46
25.19	Elevator Links	46
25.20	Circulating Sub	46
25.21	Upper Kelly Cock.....	46
25.22	Lower Kelly Cock.....	46
25.23	Inside BOP	46
25.24	Drop-in Valve Assembly	47
25.25	Float Valves And TOTCO Ring	47
25.26	Wiper Rubbers	47
25.27	Mud Saver Bucket	47
25.28	Bit Sub / Crossover Sub	47
25.29	Bit Breakers.....	47
25.30	Bit Calipers	47
25.31	BHA Roller Assemblies	48
25.32	Casing Circulating Head.....	48
25.33	Casing Drift.....	48
25.34	RTTS Packer.....	48
26.0	TUBULAR HANDLING TOOLS.....	49
26.1	Casing Side Door Elevators	49
26.2	Slip Type Elevator And Spider	49
26.3	Casing Bushing	49
26.4	Casing Slip	49
26.5	Single Joint Casing Elevators.....	49
26.6	Manual DP, Casing And Tubing Tongs	49
26.7	Power Unit And Power Casing Tongs	49
26.8	Casing Thread Protectors : None.....	49
26.9	Casing Scraper : None	49
26.10	Tubing Elevators : None.....	49
27.0	FISHING TOOLS	50
27.1	Overshots.....	50
27.2	Fishing Jars	50
27.3	Surface Jars	50
27.4	Jar Intensifier.....	50
27.5	Bumper Subs.....	50
27.6	Junk Subs.....	50
27.7	Reverse Circulating Junk Basket	50
27.8	Jet Junk Basket.....	50
27.9	Magnets.....	51

27.10	Milling Tools	51
27.11	Internal Mechanical Cutters.....	51
27.12	External Mechanical Cutters	51
27.13	Casing Spear.....	51
27.14	Safety Joint.....	51
27.15	Taper Taps	51
28.0	INSTRUMENTATION.....	52
28.1	Drilling Console	52
28.2	Drilling Recorder (Permanent Record)	52
28.3	Drift Recorder	52
28.4	Kill/Choke Manifold Gauges	52
28.5	Trip Tank Recorder	53
28.6	Meteorological	53
28.7	Navigational Equipment	53
28.8	Scale	53
28.9	Photocopier	53

1.0 DRILLING VESSEL SPECIFICATION**1.1 Unit Specification**

Unit name	: SEDCO 702
Unit type	: Semi-submersible
Unit shape	: Rectangular
Unit flag	: Liberia
Unit classification	: ABS EM PAS CSDU + A1
Expiry date	: N/A
Year of construction	: 1973
Year of last modification	: 1992 (Life Enhancement)
Propulsion assist.	: YES
Last drydock inspection	: 1997
Next drydock inspection	: 2002
Annual hull and machinery survey	: 1999
Estimated average fuel consumption per day	: Operating - 80 bbls/day
	: Moving - 45 bbls/day - no propulsion

1.2 Major Dimensions

Unit design	: SEDCO / EARL & WRIGHT 700 Series
Unit length (overall)	: 300' (91.5m) with anchors stowed
Unit width (overall)	: 275' (83.8 m) with anchors stowed
Unit height (from keel to main deck)	: 130' (39.6 m)
Unit height (from main deck to drill floor)	: 40' (12.2 m)
Drilling draft	: 75 - 85 ft (22.9 - 25.9m)
Transit draft (shallow)	: 19 - 26 ft (6.4-7.9m)
Transit draft (deep)	: 55 - 70 ft (16.8-21.3m)
Drilling displacement at 24.4m	: 25,731 ST @ 80' draft
Transit displacement at 18.3m	: 16,970 ST @ 21' draft
Lightship displacement	: 13,900 ST

1.3 Storage Capacity

Fuel oil	: 970	ST
Drilling water	: 2032	ST
Potable water	: 234	ST
Total liquid mud	: 2,486	bbl (up to 8' level)
Brine tank (utilizing stbd DW tank)	: 508	ST (2895 bbls)
Bulk bentonite/barite	: 520	ST (7,700 cu.ft.)
Bulk cement	: 361	ST (7,700 cu.ft.)
Sacks materials	: 150	ST (1,700 cu.ft.)
Pipe racks	: 1,100	ST
Base oil (utilizing stbd fuel tank)	: 3265	bbl

1.4 Detailed Variable Load

Estimated* maximum variable deck loading during :

Transit mode at 6.4m (21 ft)	: 1,200	ST
Transit mode at 16.7m (55 ft)	: 2,425	ST
Transit mode at 21.3m (70 ft)	: 3,200	ST
Drilling mode (75-83.5 ft)	: 3,325	ST
Survival mode (70 ft)	: 2,000	ST

* These figures are calculated from specific load cases and depend on load distribution. Only VCG values control rig stability

1.5 Operational Condition And Limits

1.5.1	Combined Forces	<u>Operating</u>	<u>Survival</u>
	Max. wind speed (knot)	: 70	100
	Max. wave height (m)	: 21.3	33.5
	Related wave period (sec)	: 11.7	18.8
	Surface current speed (knot)	: 2.4	2.4
	Air gap (m)	: 14.6 - 8.5	20.7 - 16.2
1.5.2	Operating Depths		
	Max. drilling depth with 5" DP	: 4,500 m	
	Max. drilling depth with 5" & 3-1/2" DP	: 7,500 m	
	Max. operating water depths	: 460 m	
	Min. operating water depth	: 45 m	
	Min. operating transit depth with max. variable load	: 28 m	
	Min. operating transit depth with no variable load	: 6.4 m	
	Max. operating air gap if unit is fully equipped	: 15 m	

2.0 THRUSTERS AND TOWING REQUIREMENT

2.1 Thrusters : 4 x PLEUGER 1600 hp thrusters (2 in each hull)

2.2 Towing / Anchor Handling Requirement**2.2.1 Long Distance Towing (> 700 nm)**

Quantity of towing/anchor
handling vessel required : 1

HP rating of each : 12,000 hp
Bollard pull of each : 150 ST minimum Bollard Pull

**2.2.2 In-Field Towing
(Between Locations)**

Quantity of towing/anchor
handling vessel required : 2
HP rating of each : 80 ST minimum Bollard Pull

2.2.3 Towing Line

Number and type of towing lines : 1 each 2-part bridle
Towing lines OD : 63 mm

3.0 MOORING EQUIPMENT**3.1 Standard Anchor Pattern**

Line number : 8
 Degrees : 45^o-45^o, 60^o-30^o

3.2 Anchor Line Specification

No. of anchor lines : 8
 Anchor line system (chain, cable, mixed) : Chain
 Diameter of the line : 3" ORQ
 Weight in air : 125 kg/m
 Breaking strength : 1,045,000 lbs
 Normal operating tension : 250 kips
 Max. operating tension : 350 kips
 Total line length : 4,300'
 Usable line length : 4000 ft.
 Date of lines last inspection : 1998

3.3 Anchor Winches / Windlasses

Quantity of anchor winches : 8
 Make and type : BAYLOR Series 350
 Powered by : EMD D79 Electric Motor
 Max. rated pull : 500 kips (1,000,000 static capacity)
 At speed of : 0.23 m/s
 Are locally operated : Yes
 Are remote operated : Yes
 HP : 800 hp
 Brake capacity : 455,000 kgf
 Do anchors have emergency release system : No

3.4 Mechanical Brakes

Make and type : BAYLOR Band
 Powered by : Air Motor / Manual
 Max. holding load : 455,000 kgf

3.5 Dynamic Brakes

Make and type : Dynamic Payout
 Dynamic holding effect : 500 kips
 Are brakes locally operated : Yes
 Are brakes remote operated : Yes

3.6 Fairlead

Make and type : BAYLOR MODEL 500
 Operating through an angle of : 180^o

3.7 Primary Anchors

Quantity of primary anchors : 8
 Weight in air : 12 Ton
 Make and type : Vryhof Stevpris high holding power anchors

3.8 Spare Anchors (Piggyback)

Quantity of spare anchors : 4
 Weight in air : 30,000 lbs
 Make and type : LWT

3.9 Pennant Lines

Quantity : Nil
 Diameter :
 Length of each section :

3.10 Anchor Buoys

Quantity : 4
 Make and type : Misc
 Length : 3 m
 Width : 2 m
 Positive buoyancy : 500 kgf

3.11 Chain Chasers

Quantity : 8
 Type : Permanent J-hook

3.12 Mooring Instrumentation**3.12.1 Load cells to monitor line tension**

(a) **Local Readout**
 make and type : Martin Decker Gauge
 installation site : Local winch

(b) **Remote Readout**
 make and type : BAYLOR Custom
 Installation site : Barge control room

3.12.2 Line Feed Readout : BAYLOR - Feet Per Minute.

3.12.3 Vessel Position Reference

System : SIMRAD HPR310D (See 24.1)

4.0 UNIT AUXILIARY EQUIPMENT

4.1 Living Quarters

Total people accommodated	:	108
Quantity of single bedroom	:	0
Quantity of 2-men bedroom	:	10
Quantity of 4-men bedroom	:	22
Number of hospitals	:	1
Number of sick-bed	:	2
Number of galley	:	1
Number of people accommodated in galley	:	28
Number of recreation room	:	1
Number of Contractor's office	:	1
Number of Company's representative office (complete with desk, chair, filing cabinets, white board, telephone and all other necessary furniture)	:	1
Air-conditioning for the living quarters (including hospital, navigational space, etc)	:	Yes

4.2 Cranes

4.2.1 Crane

Quantity of forward cranes	:	2
Make and type	:	NATIONAL OS-435
Boom length	:	120'
Type of power	:	Diesel/hydraulic
Continuous power	:	350 hp
Min. boom straddle	:	9.1m
Max. hoisting @ min. Boom straddle	:	50.6 MT on deck 31.0 MT over side
Max. boom straddle	:	36.6 m
Max. hoisting @ max. Boom straddle	:	14.1 MT on deck 8.5 MT over side
Date of crane last load tested	:	Q1/95

4.2.2 Auxilliary Crane	:	2 ea VMW, max load 5 tons @30' radius 10 tons @ 9' radius.
------------------------	---	---

4.3 Helicopter Deck

Length	:	27 m
Width	:	27 m
Certified for type of helicopter	:	Sikorsky S-61N,
Type of helicopter refuelling system	:	N/A
Capacity of helifuel storage	:	Nil
Type of insurance and safety reg. authorities	:	Liberia
Fire extinguishing system installed	:	Foam (3% AFFF). 600 LT.
Wire mesh extension beyond perimeter of helideck	:	1.5 m
Date helifuel system was last audited	:	N/A

4.4 Well Testing & Production Equipment**(a) Burner Boom Mounting**

: Aft port and starboard horizontal
(Booms are not part of S702 equipment list.)

(b) Piping Specification**i) Production Standpipe**

4.313" OD, 2.687" ID, ASTM A519 Gr 4130, 10K, H2S services, 3" FMC fig 1502.

ii) Kill Line Standpipe

(S702 cement manifold) 4" OD, 2.73" ID, ASTM A519 Gr 4130, 10 K, H2S Services, 2" fig 1502

iii) Kill Line Hose

3.9" OD, 2.78" ID, stainless steel armoured, neoprene, 10K, 2" FMC fig 1502.

iv) Production Testing Hose

N/A

v) Hi-P Piping from Rig Floor to Choke

4.313" OD, 2.687" ID, ASTM A519 Gr 4130, 10K, H2S services, 3" FMC fig 1502.

vi) Lo-P Gas Piping from Test Area to Booms

4.5" OD, 3.941" ID, ASTM A106 Gr B, sch 80, 1400 psi, API flanges.

vii) Lo-P Oil Piping from Test Area to Booms

3.5" OD, 3" ID, ASTM A106 Gr B, sch 80, 1400 psi, API flanges

viii) Lo-P Water Piping from Test Area to Booms

3.5" OD, 3" ID, ASTM A106 Gr B, sch 40, 100 psi, API flanges

ix) Lo-P Vent Line from Test Area to Booms

6.625"OD, 5.931" ID, ASTM A106 Gr B, sch 40, 1150 psi, API flanges

ix) Lo-P Air Piping from Test Area to Booms

2.25"OD, 2" ID, ASTM A106 Gr B, sch 40, 150 psi, API flanges

Note : Electrical Supply is 480 V, 3 phase, 60 Hz.

(c) Subsea Tree Handling System

: One set of skid beams and hydraulic jacks for skidding subsea trees and similar structures from starboard deck into moonpool.

4.5 Electronic Testing Equipment

: Meters, test panels etc.

4.6 Utility Hoist

3 ea on Drill Floor

BEEBE, 4500P - 125 - 12 HP, 4,500 lbs pull

4 ea on Spider Deck

BEEBE, 1500P - 125 - 24 HP, 5000 lbs pull

1 ea on Catwalk

BEEBE, 4500P - 125 - 12 HP, 4,500 lbs pull

6 ea for Pod and Guideline Tensioners

INGERSOLL RAND, 28,000 lbs stall

2 ea on Monkey Board

BEEBE, 1000P - 60 - 12P, 1800 lbs pull

2 ea Man Rider

BEEBE, 3285-JSPMR-24

(1 ea on Rig Floor, 1 ea on Spider deck)

1 ea Man Rider (on Drill Floor)

INGERSOLL RAND, FA5MR24MK1G, 6880 lbs

4.7 Other Equipment And Facilities

4.7.1 Workshops

- Mechanical : Miscellaneous small tools with lathe machine and drill press.
- Subsea : Miscellaneous small tools.
- Electrical : Miscellaneous small tools.
- Welder : Miscellaneous welding and cutting tools.

4.7.2 Warehouses

- : Space for small stores, heavy stores and contractor's items. Dehumidified storage for rubber items.

4.7.3 Mud Engineer Testing Facility

- : 2 x 2 x 2.5m - in sack store. Furnished with table and sink, 120 psi air supply, drilling and potable water, 110 and 220 V power supply, air conditioning.

4.7.4 Forklift Truck

- Quantity : 1 Caterpillar V50 DSA
- Make and type : Perkins Diesel Engine rated for zone 1 classified area
- Rated capacity : 5,000 Lbs
- Powered by : Caterpillar Diesel engine
- Certified for hazardous area : Yes

4.7.5 Potable Water Distillation Unit & Pump

- Pump : Two crown submersible #5HC125SWC and Franklin 10 HP submersible motor
- Distillation Unit : 1 ea Aquachem - S600 Spec E, 600 gph
: 1 ea Alpha Laval, JWP 3.6C 125D, 50 T/day

4.7.6 Photocopier

- : 1

4.7.7 Personal Computers

- : Windows NT Network, 1 server, 10 work stations

4.7.8 Air System

High Pressure Air Compressor

- Quantity : 2
- Make and type : Price
- Rated capacity (cu.ft/min) : 80 cfm
- Max. air pressure : 2200 psi

Low Pressure Air Compressor

- | | | |
|----------------------------|------------------|-------------------|
| Quantity | : 2 | 1 * |
| Make and type | : GARDNER DENVER | GARDNER DENVER |
| Rated capacity (cu.ft/min) | : 420 cfm | 1100cfm @ 120 psi |
| Max. air pressure | : 120 psi | 150 psi |

* One air compressor can be used for well testing purposes.

4.7.9 Drillwater Pumps

- Quantity : 2
- Make and type : GOULD 3196 (one in each pump room, driven by 60 hp motor)
- Capacity : 600 (each) gpm (@ 160ft head)

- Total capacity : 1200 gpm
- 4.7.9.1 Seawater Pumps**
- Quantity : 2
 Make and type : GOULD 3404 & 3410
 Capacity : 1,350 (each) gpm (@ 160ft head)
 Total capacity : 2,700 gpm
- 4.7.10 Sewage Treatment System** : One Ompipure unit
- 4.7.11 High Pressure Wash-Down System** : Yes
- 4.7.12 Sludge Pumps (For Vacuum and Transfer of Mud)**
- | | | |
|--------------|---------------------|-------------------|
| Location | : Drill Floor | Mud Pit Room |
| Type | : Pneumatic | Pneumatic |
| Manufacturer | : Chicago Pneumatic | Chicago Pneumatic |
| Model | : CP-77 | CP-72 |
- 4.7.13 Garbage Compactor**
- Location : Starboard main deck
 Type : Air powered hydraulic ram
 Manufacturer : Ensco
 Model : Scavenger SA
 Container volume : 30 cu ft

5.0 SPACE FOR THIRD PARTY EQUIPMENT

5.1 Cementing Unit

(Provided by Dowell)

Location : Cement room, adjacent to sack room

5.2 Mud Logging Unit

Space Provided: : For unit of 2.4m x 6m
 Location : On a raised platform in front of the sack room

5.3 Electric Logging Unit

Location : End of catwalk.

5.4 ROV Unit

Moonpool for ROV unit provided.

Dimension : 3.6 x 3.6 m
 Location : Port Forward

5.5 Third Party Contractor Office

Location : Platform forward of BOP house, above ROV area
 Dimensions : 2.4 m x 6.0 m

5.6 MWD Unit

Space Provided: : 4.6 m x 3.0 m
 Location : On a raised platform in front of the sack room
 and above mud logging unit

6.0 POWER PLANT AND TRANSMISSION**6.1 DC Generator Set**

: None

6.2 AC Generator Set

No. of set : 3 each
 Make and type : EMD A20-C1
 Max. continuous power : 2100 kw
 Output voltage : 4,160
 Frequency : 60 Hz
 At rotation speed of : 900 rpm

6.3 Diesel Engines

No. of set : 3
 Make and type : EMD 16-645-E9
 Max. continuous power : 2,875 hp
 At rotation speed of : 900 rpm

6.4 SCR System

No. of set : 8
 Make and type : THYRIG
 Max. amps : 2000 A
 Max. output voltage : 4160 V

6.5 Transformer System

No. of transformers	: 6	1
Make and type	: WESTINGHOUSE	WESTINGHOUSE
Max. continuous power	: 2,000 KVA	2,500 KVA
Input/output volts	: 4160/600	4160/480
Frequency	: 60 Hz	60 Hz

6.6 Distribution Centers

6.6.1 No. of drilling motors : 10
 Power of each : 800 hp

6.6.2 Mooring Winch motors : 8
 Power of each : 600 KVA
 Total power : 2,400 KVA

6.6.3 Unit service motors and lighting
 Total power : <2,500 KVA

6.7 DC And AC Electric Motors Inventory**6.7.1 For Drawworks**

No. of motors : 2
 Make and type : EMD D79
 Continuous power : 800 hp

6.7.2 For Each Mud Pump

No. of motors : 2
 Make and type : EMD D79
 Continuous power : 800 hp

6.7.3	For Rotary Table	
	No. of motors	: 1
	Make and type	: EMD D79
	Continuous power	: 800 hp
6.7.4	For Cementing Unit	: 2 Diesel QM8V-71 (Provided by Dowell) (Not part of S702 Equipment List)
6.7.5	For Mooring Windlasses	
	No. of motors	: 1 per windlass
	Make and type	: EMD D-79
	Continuous power	: 800 hp
6.7.6	For Electrical Mud Agitators	
	No. of motors	: 5
	Make and type	: US ELECTRIC 256T
	Continuous power	: Each 20 hp
6.7.7	For Water And Centrifugal Pumps	
	No. of motors	: 4
	Make and type	: US ELECTRIC 356
	Continuous power	: Each 75 hp
6.7.8	For Top Drive System	:
	No. of motors	: 1
	Make and type	: GE-752
	Continuous power	: 1100 hp

7.0 SAFETY EQUIPMENT

7.1 Survival Craft And Life Raft

7.1.1 Life Boat

Quantity/ Make and type : 2 ea Davit-gravity totally enclosed Whittaker W5000 - 58 man ea.
 : 2 ea WATERCRAFT x 2 self-righting totally enclosed 58 man
 Are they fire proof : Yes
 Are they self propelled : Yes
 Certification authority : ABS
 Launching device descript. : Davits
 Date installed : 1992
 Type of emergency radio : ITT Mackey Type 403A
 Type & frequency of location beacon : GME

7.1.2 Rescue Boat With Engine

Quantity : None

7.1.3 Life Raft

Quantity : 1 4 (Davit launched)
 Make and type : Viking 25DSB Viking DKF
 For number of people : 25 each 25 each
 Certification : ABS ABS
 Located at : At rig's stern 2 ea Port/Stbd main deck

7.2 Life Jackets

Quantity : 284
 Type : USSG approved life jackets + adequate number of work vests

7.3 Life Buoys

Quantity total : 14
 Quantity with smoke generator : 7
 Quantity with water light : 7
 Locations : Main deck, crane pedestal outboard and moonpool.

7.4 Sick Bay

No. of beds : 2

7.5 First Aid

7.5.1 Medical supplies and equipment : Full offshore hospital as per Sedco Forex standards.
 7.5.2 Stretchers
 - quantity : 3
 - location : Various
 7.5.3 Special personnel stretcher
 - quantity : 3 Vertical Stretchers
 - location : Hospital

7.5.4	Apparatus for artificial respiration - quantity - make and type - location	: 1 : OXY-VIVA 4 : Hospital
7.5.5	Air masks - quantity - make and type - location	: 6 : Hudson : Hospital
7.5.6	Emergency eyewash/shower - quantity - make and type - location	: Eyewash 4, Shower 3 : Speakman Pratt : Various
7.6	Derrick Safety Equipment	: Escape device at monkey board. Clear descent path to engine house rooftop.
7.7	Personnel Safety Apparel	: All PPE i.e coveralls,safety boots,hard hats, safety glasses, etc. available. Company safety policies dictate the use of same.
7.8	Electrical Safety Equipment	: Fibreglass ladders used by electricians. Rubber matting as above, fitted around switchgear room.
7.9	Breathing Apparatus	
	Quantity and type	: 12 SCOTT AIRPAK SKA-PAL 30 min.
7.10	Warning Signs	: Local signs will be posted if required.
7.11	Emergency Equipment Boxes	
	Quantity	: 5
	Description	: As above
	Location	: 4 at helideck and 1 at main deck.
7.12	Fireman's Outfit	
	Quantity	: 4 fireman's outfits and 1 entry suit
7.13	Work Vests	
	Quantity/ Make and type	: 12 ea STEARNS USCG APPROVED : 10 ea Billy Pugh
7.14	Safety Guards And Exits	: All guards comply with class and flag and industrial regulations.
7.15	Safety Chains And Clamps	: Safety lines fitted to all suspended equipment.
7.16	Spark Arrestors And Flashback Arrestors	: On main engines, emergency generator and crane engines

7.17 Pollution Control System

: Oily water separator installed below starboard main deck.

7.18 Auxiliary Safety Equipment

Safety belts, personnel basket, emergency escape rope ladders and automatic fog horn : All available.

8.0 EMERGENCY ELECTRICAL SYSTEM**8.1 Emergency Power Generator(s)**

Quantity : 1
 Make and type : DETROIT DIESEL 16V71
 Max. continuous power : 350 KW
 Output volts : 480
 Frequency : 60 Hz
 At rotary speed : 1,800 rpm

8.2 Does the emergency generator come into service automatically in the event of main circuit failure : Yes

8.3 Does the emergency generator have its own independent panel and circuit : Yes

8.4 Battery Powered Emergency System

Navigation visual signals : Yes
 Navigation sound signals : Yes
 Radio telecon system : Yes
 P.A. System : Yes
 Emergency lights along the escape route : Yes
 Elmago Brake : Yes
 Helideck lighting system : No
 All ship abandon stations : Yes
 Fire Detection : Yes
 BOP's control panels : Yes

Does the emergency battery come into service automatically in the event the emergency generator fails : Yes

Time of continuous feeding for all above users guaranteed by the emergency battery as per regulatory requirements : 30 mins

9.0 H2S, COMBUSTIBLE, BLOWOUT AND FIRE DETECTION AND WARNING SYSTEM

9.1 Fixed Installations

9.1.1 Mud Pit-Level Indicator

Make and type : AUTELEC
 Installation sites : each pit
 Warning instrument sites : Rig Floor

9.1.2 Mud Flow Indicator

Make and type : AUTELEC
 Installation sites : Flow line
 Warning instrument sites : Rig Floor

9.1.3 Continuous H2S Monitoring System

Make and type : Monitor 2601
 Warning instrument type : Light/horn/alarm
 Sample points : Bell Nipple, Pit Room, Pump Room, Air intake living quarter, Drill Floor

9.1.4 Fire Detection

Make and type : CEREBUS CT10-04/ Notifiers
 Detection points : Living Quarters / Various
 Warning instrument type : Alarm
 Warning instrument sites : Control room

9.2 Portable Instruments

9.2.1 Gas Detectors (Combustible Gas)

Quantity/ Make and type : 1 Gastech Model 1058 gas detection system with 30 sensors located throughout drilling rig. Readouts & alarms are located in BCR.

9.2.2 Sour Gas Detection (H2S)

Quantity/ Make and type : 1 Drager

10.0 FIRE EXTINGUISHING EQUIPMENT**10.1 FIXED CO2 System**

: CO2 total flooding system.
Paint locker, engine room, emerg. Gen. Room,
thruster spaces and galley.

10.2 Dry Chemical Units**(a) Wheeled units with hoses**

: 2 ea 125lb
2 ea 150lb

**(b) Hand held
- quantity and type
- location**

: 54 Various sizes
: Various around rig

10.3 Foam Unit

Quantity and type

: One National 200gal proportioner two turret foam
guns with complete facility provided for Helideck.

10.4 CO2 UnitsQuantity and type
Locations

: 5 each 10lbs / 6 each 15 lbs. / 1 each 100 lbs
: Switchgear Rm, Control Rm, Emerg
GeneratorRm, Radio Rm, Laundry, Drill floor,
Warehouse, Helideck 100 lbs.

10.5 Fire Pump

: 2 independent centrifugal pumps (mission 2 x 3)
used as fire pumps (located at separate
locations) to supply SW to fire stations.

10.6 Fire Stations

21 ea located in various locations around the rig.

10.7 Detection

9v battery operated smoke detectors and one
heat activated device by NOTIFIER Corporation

11.0 COMMUNICATION EQUIPMENT**11.1 Radio Equipment - GMDSS**

Model : Sailor SP3110
 : VHF transceiver with 18 simplex channels
 : Satcom C

11.2 Radio Equipment - VHF-FM Type

Quantity : 1
 Model : SAILOR RT2047
 Frequency range Simplex : 155.400 / 158.000 Mhz
 Frequency range Duplex : 160.000 / 162.600 MHz
 Output watt : 25 watts
 Suitable for communicating with : Supply vessels/ Shore

11.3 VHF Ground To Helicopter

Quantity : 1
 Model : Jorton TR6102
 Frequency range : Aircraft frequency
 Output watt : 10

11.4 Handheld Aeronautical VHF Radio

Quantity : 1
 Model : Bendix King Model KX98

11.5 Radio Beacon Homing Device For Helicopter

Quantity : 1
 Make : Southern Avionics
 Model : SS-800AVS
 Output watt : 100 watt
 Frequency range : 190-625 kHz

**11.6 Satellite Communication System
(i.e. MARISAT)**

Model : Marisat "A" MIT
 Type : MCS 9120

11.7 Interior Communication

Telephone system : One electric powered onboard telephone system with 32 stations. Also 2 sound powered backup emergency phone system.
 Public address : PENWALT AP-A450
 Sound powered telephone : HOSE McCann
 Portable (hand held) marine VHF-FM Transceiver : 6 ea, 3&1 watts output (selectable). Fixed frequency channel selectable marine channels 6,8,12 and 16.

11.8 Fax machine

Make & Model : Canon, FAX270S

12.0 NAVIGATION EQUIPMENT**12.1 Magnetic Compass**

Model & Quantity : One AMERICAN BINICAL magnetic compass
: Radio direction finder; ITT Mackay Marine 4004A
: Loran-C-Furuno 90
Gyro compass : Model MK37 Mod D Sperry Gyro Compass.

12.2 Navigational Aids

: Course recorder; Sperry Gyroscope #65091TS

12.3 Radar Unit

: One Furuno Model FR8250D

12.4 Obstruction Light System

: Tideland Signal Corporation obstruction light.

12.5 Fog Horn System

: Tideland ECV 645A.

13.0 DRILLING RIG SPECIFICATION**13.1 Derrick**

Make : LEE C MOORE
 Height : 185 ft
 Width of base : 50 ft x 40ft
 Width of top : 10 ft
 Static hook load capacity : 1,000,000 lbs. With 12 lines
 No. of lines : 10 or 12

Racking platform capacity for
 - 5" drill pipe : 25,000 ft
 - 6-1/2" drill collar : 14 stands of drill collars
 - 8" and 9-1/2" drill collars

Type of racking system : Manual
 No. of racking arm : None
 Locking device on fingers : Yes

13.2 Casing Stabbing Platform

Min. height from drill floor : 30 ft., with "hinged" designed platform
 Min. Vertical travel : 12 ft.
 Powered by : Air winch for vertical travel
 : Air cylinder for horizontal travel
 Safety Features : Automatic failsafe brake on air winch;
 : Spring loaded safety lock on carriage;
 : Spring loaded latch on carriage when retracted

13.3 Derrick Substructure

Make : SEDCO 700 EARL & WRIGHT
 Height : 40 ft
 Dimension : 50ft x 40ft
 Simultaneous capacity of setback and rotary loads : 1,400,000 lbs

13.4 Crown Block

Make and type : LEE C. MOORE
 Rated capacity : 500 T
 No. of sheaves : 7
 Diameter of sheaves : 60"
 Sheave groove size : 1-1/2"
 Sandline groove size : 9/16"
 Catline groove size : N/A

13.5 Travelling Block

Make and type : OILWELL B-500
 No. of sheaves : 6
 Diameter of sheaves : 60"
 Sheave groove size : 1-1/2"
 Rated capacity : 450 MT

13.6 Hook

Make and type : BJ Dynaplex 5500
 Rated capacity : 450 MT

13.7 Drilling Line

Size and length : 1-1/2"
 Type : SOUTHWEST 6x19 EIPS

	Breaking strength	:	Nominal strength 104 MT
13.8	Sandline		
	Size	:	9 / 16"
	Capacity of drum	:	24,960'
	Length of line installed	:	Nil
13.9	Motion Compensator		
	Make and type	:	NL SHAFFER DSC-18-400
	Rated capacity	:	182 MT (400 kips)
	Stroke	:	18 ft
	Lock-out capacity	:	450 MT (500 Ton)
13.10	Swivel		
	Make and type	:	NATIONAL P500
	Rated capacity	:	500 Tons
	Working pressure	:	5,000 psi
13.11	Deadline Anchor		
	Make and type	:	NATIONAL EB
	Capacity	:	900,000 lbs. with 12 lines
13.12	Drawwork Assembly		
	Make and type	:	OILWELL E-3000
	Lebus groove for line size	:	1-1/2"
	Make and type of make up cathead	:	FOSTER 24 AK
	Make and type of break out cathead	:	FOSTER 37AK
	Make and type of auxiliary brake	:	ELMAGCO 7838
	Capacity of auxiliary brake	:	450 MT
	Make and type of crown-o-matic	:	STEWART & STEVENSON CBS-ST
	Sandline reel length capacity	:	24,960 ft
	Number of drive motors on drawworks	:	2
	Type of motors	:	EMD D79
	Continuous power of each motor	:	800 hp
13.13	Rotary Table		
	Make and type	:	OILWELL A49-1/2"
	Max. opening bore	:	49-1/2"
	Make and type of drive motor	:	EMD D79
	Pneumatic brake	:	Yes
	Make and type of master bushing	:	VARCO MPCH
	Make and type of kelly bushing	:	VARCO 27 HDP
	Lock down assembly	:	Yes
	Capacity	:	800 Tons (Static Load)

14.0 RIG FLOOR EQUIPMENT**14.1 Hydraulic Cathead (EZY Torque)**

: DRILCO Ezy Torque

14.2 Kelly Spinner (Power Sub)

: VARCO 6600

14.3 Spinning Wrench

: VARCO SSW 40

14.4 Wireline Measuring Assembly (Slickline)

Make and type : MATHEY Retriever
 Line size and length : 0.092" x 15,000 ft
 Type of depth indicator : Local readout
 Type and HP of motor : 15 hp

14.5 Hydraulic Testing Pump

Make and type : Koomey TM1003
 Max. working pressure : 10,000 psi

14.6 Iron Roughneck

Manufacturer : Varco
 Type : AR3200
 Tubular OD : 3 1/2" DP - 9 3/4" DC
 Spin torque : 2000 ft-lb (5" DP)
 Make up / breakout torque : 100,000 ft-lbs / 120,000 ft-lbs.

15.0 MUD CIRCULATION SYSTEM**15.1 Mud Pumps**

Quantity	:	3 each
Make & Model	:	OILWELL A-1700 PT
Type of pulsation dampener	:	HYDRIL K20-5000
Type of reset relief valve	:	RETSCO
Quantity and type of charge pump	:	3 of MISSION 6x8
Type and HP of charge pump motor	:	60 hp AC motor
Quantity of mud pump drive motor	:	2 per pump
Type of mud pump drive motor	:	EMD D79
Continuous rating of each motor	:	800 hp
Liner sizes supplied	:	5 1/2" - 6" - 6-1/2"
Max discharge pressures	:	7" - 2900 PSI
	:	6 1/2" - 3200 PSI
	:	6" - 3600 PSI
	:	5 1/2" - 4200 PSI

15.2 Mud Pump Discharge Lines

Quantity	:	3
Size	:	5"
Working pressure	:	5,000 psi

15.3 Standpipe Manifold

Quantity of standpipes	:	2
Make	:	SEDCO FOREX
Size (OD and ID)	:	6-5/8" and 5-3/16"
Standpipe working pressure	:	5,000 psi
Gooseneck working pressure	:	5,000 psi
Manifold working pressure	:	5,000 psi

15.4 Rotary Hoses

Quantity	:	2
Make	:	1 ea Gates, 1 ea Multiflex
Inside diameter	:	3-1/2" (both)
Length	:	87 ft (both)
Working pressure	:	5,000 psi

15.5 Cementing Hose

Quantity	:	1
Make	:	Gates
Inside diameter	:	2"
Length	:	60 ft
Working pressure	:	5,000 psi

16.0 LIQUID MUD STORAGE**16.1 Mud Tanks****Tank Number 1**

Used as : Active #1
 Volume : 496 bbls
 Bbls/ft : 62

Tank Number 2

Used as : Active #2
 Volume : 467 bbls
 Bbls/ft : 58

Tank Number 3

Used as : Reserve #1
 Volume : 467 bbls
 Bbls/ft : 58

Tank Number 4

Used as : Reserve #2
 Volume : 496 bbls
 Bbls/ft : 62

Tank Number 5

Used as : Slug Pit
 Volume : 58 bbls
 Bbls/ft : 7.3

Tank Number 6

Used as : Sand Trap #1
 Volume : 116 bbls
 Bbls/ft : 14.5

Tank Number 7

Used as : Sand Trap #2
 Volume : 116 bbls
 Bbls/ft : 14.5

Tank Number 8

Used as : Degasser (1 & 2)
 Volume : 270 bbls total
 Bbls/ft : 16.9 each

* ASSUMES TANKS FILLED TO 8' LEVEL

17.0	MUD MIXING AND TREATMENT SYSTEM		
17.1	Mud Mixing Pumps		
	Quantity	:	2
	Make and type	:	MISSION 6 x 8
	Driven by type of motor	:	US ELECTRIC 405T
	Continuous power	:	100 hp 1750 RPM complete with two mud mixing hoppers
17.2	Electrical Mud Mixers/Agitators		
	Quantity	:	4
	Make	:	LIGHTNIN
	Type	:	85Q20
	Powered by type of motor	:	US ELECTRIC 256T
	Continuous power	:	20 hp
17.3	Bottom Guns		
	Quantity	:	9
	Type	:	Mud Gun
17.4	Mixing Hoppers		
	Quantity	:	2
	Type	:	VENTURI with gravity feed
	Rated capacity	:	N/A
17.5	Mud Shearing Unit		
		:	None
17.6	Chemical Mixing Tank		
		:	1 Caustic mix tank in pit room.
17.7	Shale Shakers		
	Quantity	:	3
	Make	:	THULE
	Type	:	VSM100
		:	3
		:	BRANDT
		:	Tandem
17.8	Degasser		
	Make and type	:	SWACO DRESSER G1180
	Flow rate capacity	:	1000 gpm
17.9	Desander		
	Make and type	:	Pioneer S-3-72
	No. of cones	:	3
	Size of cones	:	12"
	Flow rate capacity	:	1500 gpm
	Pump size	:	MISSION 6x8
	Type and hp of drive motor	:	US ELECTRIC 405T - 60 hp 1800 RPM
17.10	Desilter		
	Make and type	:	BRANDT SE-16
	No. of cones	:	16
	Size of cones	:	4"
	Flow rate capacity	:	800 gpm @ 40 psi
	Pump size	:	MISSION 6x8
	Type and hp of drive motor	:	US ELECTRIC 405T - 100 hp, 1800 RPM

17.11	Mud Cleaners	:	N/A
17.14	Mud Gas Separator	:	Sedco Forex Design
17.15	Trip Tank		
	Volume	:	26 bbls
	Level indicator measuring accuracy	:	1/2 bbl
	Level indicator visible from driller's side	:	Yes

18.0 DRY CEMENT AND MUD BULK STORAGE AND TRANSFER SYSTEM**18.1 P-Tank**

Quantity : 8 pressurised storage tanks for cement, barite, or bentonite
 Capacity : 1925 cu. ft each
 Installation site : Main deck (4 on port, 4 on starboard)
 Type of tank weight load cell : MARTIN DECKER hydraulic with model B11140
 -3000 Martin Decker weight indicator scale 0-300,000 lbs
 Total volume capacity : 15,400 cu. ft.

18.2 Surge Tank For Cement

Quantity : 1
 Capacity : 70 cu. ft
 Type of load cell : Hydraulic, Martin Decker weight indicator scale 0-30,000 lbs

18.3 Surge Tank For Barite/ Bentonite

Quantity : 1
 Capacity : 4.5 MT
 Type of load cell : Hydraulic

18.4 Transfer System

Type of air compressor : Rig air compressors
 Flow rating : Transfer using air reduced from rig air system, complete with dryers and one 108 cu. ft air receiver tank.
 Working pressure : 40 psi

18.5 Supply Hoses

No. of loading stations : 2 - one each at port and starboard.
 Quantity for fuel : 2
 Size and connection : 4" Camlock
 Quantity for base oil : 1
 Size and connection : 4" Camlock, Dry-Break
 Quantity for drill water : 2
 Size and connection : 4" Camlock
 Quantity for potable water : None
 Size and connection :
 Quantity for bulk barite/bentonite/ cement : 2
 Size and connection : 4" Camlock

19.0 CEMENTING SYSTEM**19.1 Cementing Unit**

Make and type : Dowell CP361
(Not part of S702 equipment list)

19.2 Cementing Discharging Lines And Manifold

Quantity of discharge lines : 1
Nominal diameter : 3" x 10,000 psi
Manifold working pressure : 10,000 psi

20.0 BLOWOUT PREVENTION SYSTEM**20.1 Spherical/Bag Type Preventer**

Quantity : 2
 Make and type : SHAFFER Spherical
 Size and WP : 18-3/4" x 5,000 psi

20.2 Ram Type Preventer

Quantity : 4
 Make and type : CAMERON Type 'U'
 Single or double : 2 - double
 Size and WP : 18-3/4" x 10,000 psi, H₂S Service

20.3 Kill/Choke Valves

Quantity : 8
 Make and type : CAMERON "F" Model
 Size and WP : 3-1/16" x 10,000 psi
 H₂S service : Yes

20.4 Pipe Rams Available

Quantity of blind/shear : 1 pair
 Quantity of 5" : 2 pairs
 Quantity of 3-1/2" : 1 pair
 Quantity of variable and size range : 1 pair 3-1/2" - 7 5/8"

20.5 Connecting Line

Loop type connecting lines from riser
 kill/choke lines to BOP kill/choke lines : COFLEXIP hose 3" x 10,000 psi

20.6 BOP's Handling And Emergency Recovery System

: No emergency recovery system.

20.7 Ball/Flex Joint

Make and type : VETCO UNIFLEX Joint
 Size and WP : 18-3/4", 5000 psi

20.8 Wellhead Connector

Make and type : CAMERON 18 3/4", 10K collet

20.9 LMRP Connector

Make and type : CAMERON 18 3/4", 10K collet

21.0 RISER AND ASSOCIATED EQUIPMENT

21.1 Marine Riser

Outsidediameter : 21"
 Inside diameter : 19-3/4"
 Riser pipe materials : API 5L X52
 Min. yield strength : 52 ksi
 Riser connector type : REGAN FD8, 18 3/4"

21.2 Kill/Choke Lines Dimensions

Outside diameter : 3" nominal
 Inside diameter : 2.-5/8"
 Working pressure : 10,000 psi

21.3 Riser Joint

Quantity : 34
 Length of each : 50 ft
 Total length : 1700 ft

21.4 Riser Pup Joint

Quantity	:	2	2	2	1
Length of each	:	10 ft	25 ft	40 ft	35 ft

21.5 Riser Auto Fill Valve

Quantity : 1
 Size : 8"
 Connection : Flanged for mounting on modified 10 ft riser pup joint

21.6 Telescopic Joint

Make : REGAN FD8
 Outer barrel OD : 26"
 Outer barrel ID : 24-3/4"
 Total length extended : 111' 3 5/8"
 Inner barrel OD : 21-1/4"
 Inner barrel ID : 20"
 Total length collapsed : 61 ft 3- 5/8"
 Max. stroke : 50 ft
 Spare telescopic joint : 1 for use, 1 for spare.

21.7 Diverter

Make and type : REGAN KFDS-3
 Size and WP : 500 psi minimum bore 47" Diverter 7D insert packer 10"

21.8 Diverter Flex Joint

Make : OIL STATES
 GIMBALL or max. deflection : 15°, 300 psi working pressure

21.9 Diverter Lines

Min. ID : 12"
 Length : 250 ft
 Cumulative number of right angle bends : 7 Targeted
 Outlets : 1 each port and starboard

21.10 Marine Riser Spider And Handling Tools

Quantity : 1 Spider 4 Handling tools
 Make and type : REGAN

21.11 Riser Tensioning System

Make and type : RUCKER XL-REU-CW-1
 Quantity : 8
 Nominal capacity of each : 80,000 lbs
 Total nominal capacity : 640,000 lbs
 Max Stroke : 12'-6"
 Sheave OD : 52"
 Wire OD : 1 3/4"

21.12 Guide Line Tension System

Make : RUCKER XL-RED-7-10
 Quantity : 6 (4 for guidelines – 2 for pod lines)
 Nominal capacity of each : 16,000 lbs
 Total nominal capacity : 64,000 lbs
 Max. stroke : 10'
 Sheave OD : 28"
 Wire OD : 3/4"

22.0 BOP CONTROL SYSTEM AND ASSOCIATED EQUIPMENT**22.1 BOP Control System**

: KOOMEY

22.2 Surface Accumulator Unit

Model : Koomey 26.300-3S
 Installation site : Mud pump room
 Soluble oil reservoir capacity : 300 gal.
 Oil/water mix capacity : 1000 gal
 Glycol reserve capacity : 280 gal
 Number of bottles installed : 63 x 10 gal. + 10 x 15 gal
 Capacity of each bottle : 5 (working) gal.
 Total bottle capacity : 365 (working) gal.
 Bottles working pressure : 3,000 psi

22.3 Accumulator Bottles On BOP Stack

Total bottle capacity : 24 x 10 gal.
 Bottles working pressure : 3,000 psi
 For what purpose are the bottles installed : Pilot surge and manifold supply.

22.4 Triplex Pumps

Quantity : 2
 Model : T-360-60-3
 Power of drive motor : 60 hp
 Flow rate of each pump : 30 gpm
 At max. operating pressure : 3,000 psi

22.5 Air Pumps

Quantity : 2
 Model : 88860
 Flow rate of each pump : 3.5 gpm
 At max. operating pressure : 3,000 psi

22.6 Central Control Unit

: Remote controlled manipulator and selector valves for all BOP functions, regulators as required. Pressure gauges for all systems.

22.7 Driller's Control Panel

Model and type : KOOMEY / GB3K-21EX
 Low accumulator pressure warning : Yes
 Low reservoir level warning : Yes
 Low rig air pressure warning : No
 Pressure regulator for bag BOP : Yes
 Pressure regulator for subsea manifold : Yes
 Pressure regulator for kill/choke lines valves : No
 Quantity of flow meters : 1
 Quantity of gauges : 6
 Emergency push-button for automatic riser disconnect : N/A

22.8 Remote Control Panel

Quantity : 1
 Model : MERC-18 NL SHAFFER
 Installation sites : Rig Superintendent's office

22.9 Diverter Control Panel

Model : NL SHAFFER DS3K-SM-2A
 Installation sites : Mezzanine deck

22.10 Hoses, BOP Control Lines

Quantity : 2
 Length : Blue - 2174 ft, Yellow - 2052 ft
 Number of control lines : 44
 Main hydraulic lines ID : 1"
 Control lines ID : 3/16"

22.11 Hose Reels

Capacity : 2,200 ft
 No. of functions : 6

22.12 Control Pods

Quantity : 2
 Model : KOOMEY RHCS 14-21-7
 Retrievable : Yes

22.13 Test Stump

Make and type : 2 ea CAMERON Collet
 For testing : size and WP : 18-3/4" x 10,000 psi

23.0 CHOKE MANIFOLD**23.1 Valves**

Quantity : 13 2 1 3 1

Make and type : CAMERON FC

Size (inch) and working pressure(psi) : 3-1/16 4-1/8 2-1/16 3-1/8 4-1/8
10,000 10,000 10,000 5,000 5,000

H2S service : Yes

23.2 Adjustable Choke (Manual)

Quantity : 2

Make and type : CAMERON H2 - 3"

Min. choke size : Zero - positive seal

Pressure rating : 10,000 psi

23.3 Hydraulic Choke

Quantity : 2

Make and type : CAMERON SP-4910-01

Max. choke size : 2

Pressure rating : 10,000 psi

23.4 Power Choke Remote Control Panel

Make and type : CAMERON 38933

No. of gauges: 4

Unit division of gauges : Psi/bar

Supplementary operations of choke in case of power failure : None

Installation site : Drill floor

Other instruments : None

23.5 Hoses

Type of hoses from riser kill/choke lines to choke manifold : COFLEXIP

Outside/Inside diameter of hoses : 3" ID

Working pressure : 10,000 psi

H2S service : Yes

23.6 Chiksan Joints

: None

23.7 Crossover To Test BOP Casing Pipe Rams

: None

24.0 UNDERWATER AUXILIARY EQUIPMENT**24.1 Hole Position Indicator**

Make and type : Simrad HPR 410D
 Quantity : 1
 Monitor installation sites : Barge control room

24.2 Slope Indicator

Quantity : 3
 Make : REGAN
 Provision for installation : Fabricated sockets

24.3 Underwater Television

Camera : Panasonic, Model IO-ZM60
 Pan and Tilt : Hydro Products, Model RP-3
 Lights : 120 v, 250 W
 Frame : Edo Western, Model 553, telescoping
 Winch : Hydro Products, Model HA155

25.0 DRILLING EQUIPMENT**25.1 Top Drive**

: VARCO TDS-4S, 500T

25.2 Kelly

Quantity : 2
 Make : DRILCO
 Type : Hex
 Nominal size OD and ID : 5-1/4" x 3"
 Total length : 54 ft
 Working length : 40 ft

25.3 Kelly Saver Sub

Type : DTE
 Quantity : 2
 Bore size, connection : 4-1/2" IF

25.4 Kelly Test Sub

Quantity : INTEROFFSHORE
 Connections : 4-1/2" IF box x 2" WECO

25.5 5" OD Drill Pipe

Grade : S-135
 Total length : 400 jnt
 Range length per joint : +30 ft
 Weight/ft : 19.5 lb/ft
 Internally plastic coated : Yes
 Tool joint OD : 6-3/8"
 Tool joint ID : 2-3/4"
 Type of connection : NC50
 Type of hardfacing : Smooth - X, flush

25.6 5" OD Drill Pipe Pup Joints

Quantity	:	2	1	2
Grade	:	All S-135		
Length	:	5'	10'	15'
Weight/ft	:	19.5	19.5	19.5

25.7 3-1/2" OD Drill Pipe

N/A

25.8 Drill Pipe Elevators

Quantity : 2
 For OD drill pipe : 5"
 Make and type : BJ "GG"
 Rated capacity : 350 ton

25.9 Drill Pipe Slips

Quantity : 2
 For OD drill pipe : 5"
 Make and type : VARCO SDXL

25.10	Drill Pipe Power Slips			
	Make/Model	:	Varco PS-21	
	Type	:	Remote operated	
	Capacity	:	5", 7", 9 5/8", 13 5/8"	
25.11	Drill Pipe Protectors			
	Quantity	:	For all contractors drill pipe.	
25.12	5" OD Hevi-wate Drill Pipe			
	No. of joints	:	40	
	Nominal size	:	5	
	Weight/ft	:	50	
	Length of each joint	:	+30 ft	
	Tool joint OD x ID	:	6-3/8" OD x 3" ID	
	Type of connection	:	NC50	
	Hardbanding	:	Fine partical type (TW Grant Smooth X or similar)	
25.13	Drill Collars			
	25.13.1		9-1/2" Drill Collar	
	No. of joints	:	6	
	OD x ID	:	9-1/2" x 3", 216 lb/ft	
	Length of each joint	:	+30 ft	
	Type of connection	:	7-5/8" reg	
	Drill collar body type	:	Spiral	
	25.13.2		8-1/4" Drill Collar	
	No. of joints	:	30	
	OD x ID	:	8-1/4" x 2-13/16", 144 lb/ft	
	Length of each joint	:	+30 ft	
	Type of connection	:	6-5/8" reg	
	Drill collar body type	:	Spiral	
	25.13.3		6-1/2" Drill Collar	
	No. of joints	:	41	
	OD x ID	:	6-1/2" x 2-13/16", 88 lb/ft	
	Length of each joint	:	+30 ft	
	Type of connection	:	4" IF	
	Drill collar body type	:	Spiral	
	25.13.4		4-3/4" Drill Collar	
			N/A	
	25.13.5		Short/Pony Drill Collar	
	No. of joints	:	2	
	OD (inch)	:	8-1/2" and 6 1/2"	
	Length of each joint	:	10 ft	
25.14	Drill Collar Elevator			
	Not in use.	:	Lift subs for each connection size	
25.15	Lifting Sub			
	Quantity	:	3	6
	For OD drill collars	:	9-1/2"	8"
	Type of connections	:	7-5/8" reg	6-5/8" reg
				4" IF

25.16 Drill Collar Slips

Quantity	:	1	1	1	1
For OD drill collars	:	8" - 9 1/2"	6 3/4" - 8 1/4"	5 1/2" - 7"	8 1/2"-10"
Make	:	VARCO	VARCO	VARCO	VARCO
Type	:	DCS-L	DCS-L	DCS-R	DCS-C1

25.17 Safety Clamps (Dog Collars)

Quantity	:	2
Make and type	:	VARCO MPR
Size range	:	4 1/2" - 13 5/8"

25.18 Drill Pipe And Drill Collar Rotary Tonges

Quantity	:	3
Make and type	:	1 ea BJ HT-100, 1 ea BJ "SDD", 1 ea BJ "DB"
Size range	:	3-1/2" - 17"

25.19 Elevator Links

Make	:	BJ	BJ	(TDS) BJ	(TDS)BJ
Quantity	:	1	1	1	1
Length	:	11 ft	12 ft	9 ft & 13ft	15 ft
Rated capacity	:	350 ton	500 ton	350 ton	500 ton

25.20 Circulating Sub

Quantity	:	2
Type	:	1 ea Interoffshore, 1 ea Eastman
Size OD x ID	:	8 1/2" x 2 1/2", 6 1/4" x 2"
Top connection	:	6 5/8" IF, 4 1/2" IF
Bottom connection	:	6 5/8" IF, 4 1/2" IF

25.21 Upper Kelly Cock

Quantity	:	1
Make and type	:	OMSCO 701S
Working pressure	:	10,000 psi

25.22 Lower Kelly Cock

Quantity	:	2
Make and type	:	HYDRIL kelly guard
Max. OD body	:	7-3/8"
Max. ID body	:	3 1/16"
Working pressure	:	10,000 psi
Type of connections	:	1 ea 6-5/8" IF, 3 ea 4-1/2" IF

25.23 Inside BOP

Quantity	:	1
For nominal OD drillpipe	:	5"
Make and type	:	GRAY 62020
Max. OD of body	:	6-1/4"
C/W releasing tool	:	-
Working pressure	:	10,000 psi
TDS Valves	:	2
	:	1 ea Best Upper IBOP, 1 ea Best Lower IBOP

25.24 Drop-in Valve Assembly
 Quantity : 1
 For nominal OD drillpipe : 5"
 Make and type : HYDRIL checkguard#43
 Max. OD of plug : 2 3/4"
 Complete with releasing tool : #43
 Working pressure : 10K
 Connection top and bottom : 4-1/2" IF

25.25 Float Valves And TOTCO Ring
 Quantity : 2 each
 Make and type : BAKER
 For OD drill collar : 9-1/2", 8" and 6-1/2".

25.26 Wiper Rubbers
 Quantity : 2
 For OD : 5"

25.27 Mud Saver Bucket
 Quantity : 1 OKEH
 Insert sizes : 5"
 Dressed for OD drill pipe : 5"

25.28 Bit Sub / Crossover Sub

2 ea	8-5/8 Reg Box	-	7-5/8 Reg Box	
2 ea	7-5/8 Reg Box	-	7-5/8 Reg Box Float	
2 ea	7-5/8 Reg Box	-	6-5/8 Reg Box Float	
2 ea	7-5/8 Reg Pin	-	7-5/8 Reg Pin	
2 ea	7-5/8 Reg Pin	-	6-5/8 Reg Box Float	
1 ea	7-5/8 Reg Pin	-	4-1/2 IF Box	
2 ea	6-5/8 Reg Box	-	6-5/8 Reg Box Float	
2 ea	6-5/8 Reg Box	-	4-1/2 IF Pin	
2 ea	6-5/8 Reg Box	-	4 IF Pin	
1 ea	6-5/8 Reg Pin	-	6-5/8 Reg Pin	
2 ea	6-5/8 Reg Pin	-	4-1/2 IF Box	
2 ea	6-5/8 Reg Pin	-	4 IF Box	
2 ea	6-5/8 Reg Pin	-	4-1/2 IF Box	
2 ea	4-1/2 IF Box	-	4-1/2 IF Pin	
2 ea	4-1/2 IF Box	-	4 IF Pin	
2 ea	4-1/2 IF Box	-	4-1/2 IF Box	
1 ea	4-1/2 IF Box	-	4-1/2 Reg Box Float	
1 ea	4-1/2 IF Box	-	3-1/2 IF Pin	
2 ea	4-1/2 IF Pin	-	4 IF Box	
2 ea	4-1/2 IF Pin	-	4-1/2 IF Pin	
1 ea	4-1/2 IF Pin	-	3-1/2 IF Box	
1 ea	4-1/2 Reg Pin	-	4-1/2 Reg Pin	
2 ea	4-1/2 Reg Box	-	4 IF Box	Float
2 ea	4 IF Pin	-	4 IF Pin	

25.29 Bit Breakers
 : One each bit breaker to fit Contractor supplied rotary table for 26", 17-1/2", 12-1/4", 8-1/2" and 6" rock bits.

- 25.30 Bit Calipers** : One each bit caliper to fit 26", 17-1/2", 12-1/4", 8-1/2" and 6" rock bits.

- 25.31 BHA Roller Assemblies**

 - Quantity : 4
 - Location : used on pipe deck to make up BHA components prior to being picked up to drill floor.

- 25.32 Casing Circulating Head**

 - Quantity : None

- 25.33 Casing Drift**

 - Quantity : None

- 25.34 RTTS Packer** : None

26.0 TUBULAR HANDLING TOOLS

26.1 Casing Side Door Elevators

Quantity	:	1	1	1	1
For OD casing (inch)	:	20	13-3/8	9-5/8"	7"
Make and type	:	BJ Type SLX			
Rated capacity	:	150 ton			

26.2 Slip Type Elevator And Spider

Quantity	:	1 of each			
Make	:	VARCO 500 T Type DL			
Capacity	:	500 ton			
Slip insert for OD casing	:	13-3/8", 9-5/8" and 7".			

26.3 Casing Bushing

Quantity	:	1	1	1	1
For OD casing (inch)	:	20"	13-3/8"	9-5/8"	7"

26.4 Casing Slip

Quantity	:	1 each			
For OD casing	:	20", 13-3/8", 9-5/8" and 7".			
Make and type	:	VARCO CMS-XL			

26.5 Single Joint Casing Elevators

Quantity	:	2	2	2	2
For OD casing	:	20"	13-3/8"	9-5/8"	7"
Make and type	:	BJ "SJ" 5 ton.			

26.6 Manual DP, Casing And Tubing Tongs

Quantity	:	2			
Make and type	:	BJ type B			
With jaw for OD casing	:	13-3/8 - 31-5/8"			
Max. torque rating	:	25,000 ft lbs			

26.7 Power Unit And Power Casing Tongs

Quantity	:	1 ea.			
Make and type	:	Weatherford Lamb 16K			
With inserts for OD casing	:	13 3/8", 9 5/8", 7"			

26.8 Casing Thread Protectors : None

26.9 Casing Scraper : None

26.10 Tubing Elevators : None

27.0 FISHING TOOLS

27.1 Overshots

Quantity : 1 each
 Make and type : BOWEN Series 150
 : 11-1/4, 8-1/4", 5-3/4"
 Oversize guide OD for : 9-5/8, 8-1/2, 6-1/2 and 4-3/4 inch.
 Extension length : Misc.
 Grapples to catch Contractor's tools : Yes.

27.2 Fishing Jars

Quantity : 2
 Make and type : BOWEN TYPE"Z"
 OD body : 7-3/4", 6-1/4"
 Connections : 6-5/8" Reg, 4" IF

27.3 Surface Jars

Quantity : 1
 Make and type : BOWEN
 OD body : 7"
 Connections : 4-1/2" IF

27.4 Jar Intensifier

Quantity : 1
 Make and type : BOWEN
 OD body : 6-1/4"
 Connections : 4-1/2" IF

27.5 Bumper Subs

Quantity	: 1	1	1
Make and type	: BOWEN	BOWEN	BOWEN
OD body	: 8"	6-1/2"	6-3/8"
Connections	: 6-5/8" Reg	4" IF	4" IF

27.6 Junk Subs

Quantity	: 1	1	1	1
Make and type	: HE	BOWEN	BOWEN	
OD body	: 9-1/2"	8-5/8"	7"	6-1/2"
Connections	: 7-5/8" R	6-5/8" R	4-1/2" R	4-1/2" R

27.7 Reverse Circulating Junk Basket

Quantity	: 1	1	1
Make and Type	: HE	BOWEN	BOWEN
OD body	: 7-7/8"	5-1/8"	5-1/8"
Connections	: 4" IF	3-1/2" IF	3-1/2" IF

27.8 Jet Junk Basket

Quantity	: 1	1
Make and type	: HE	HE
OD body	: 11-1/4"	7-7/8"
Connections	: 6-5/8" Reg	4-1/2" Reg

27.9	Magnets		
	Quantity	: 1	1
	Make and Type	: BOWEN	BOWEN
	OD body	: 11-1/2"	7"
	Connections	: 6-5/8" reg	4-1/2" reg
27.10	Milling Tools		
	Quantity	: 2	2
	Make and type	: Flat bottom	Flat bottom
	OD body	: 12"	8"
	Connections	: 6-5/8" reg	4-1/2" reg
27.11	Internal Mechanical Cutters		
	Quantity	: None	
	Make and type	:	
	OD body	:	
	Connections	:	
	Blades for OD casing	:	
27.12	External Mechanical Cutters		
	Quantity	: None	
	Make and type	:	
	OD body	:	
	Connections	:	
	For cutting tubing size	:	
27.13	Casing Spear		
	Quantity	: None	
	Make and type	:	
	OD body	:	
	Connections	:	
	For retrieving casing size	:	
27.14	Safety Joint		
	Quantity	: 1 each	
	Make and type	: BOWEN	
	OD body	: 6-3/4" and 4-3/4"	
	Connections	: NC50 and NC38	
27.15	Taper Taps		
	Quantity	: 2 each	
	Make and type	: BOWEN	
	OD body	: 8" and 6-3/8"	
	Catch	: 4" IF and Reg; and 4" IF	
	Connections	: 6-5/8" Reg and 4-1/2" IF	

28.0 INSTRUMENTATION

28.1 Drilling Console

28.1.1	Weight Indicator	:	MARTIN DECKER "E"
28.1.2	Standpipe Pressure Gauge	:	MARTIN DECKER
	Make and type	:	MARTIN DECKER
	Pressure range	:	0 - 5,000 psi
28.1.3	Annulus Pressure Gauge	:	MARTIN DECKER
	Make and type	:	MARTIN DECKER
	Pressure range	:	0 - 10,000 psi
28.1.4	SPM Gauges	:	AUTELEC Analog MPF10
	Make and type	:	AUTELEC Analog MPF10
28.1.5	Rotary RPM Gauge	:	AUTELEC and VARCO
	Make and type	:	AUTELEC and VARCO
	Reading range	:	0 - 300 rpm
28.1.6	Rotary Torque Gauge	:	AUTELEC VPF2B
	Make and type	:	AUTELEC VPF2B
	Reading and range	:	36,000 ft/lb
28.1.7	Tong Torque Assembly And Range	:	MARTIN DECKER
	Make and type	:	MARTIN DECKER
	Reading range	:	0 -20,000 lbs
28.1.8	Mud Flow Totalizer	:	AUTELEC VPF10
	Make and type	:	AUTELEC VPF10
	Alarm type	:	Visual and sound
28.1.9	Trip Tank Gauge	:	AUTELEC VPF10
28.1.10	Mud Volume Totalizer	:	AUTELEC VPF10
	Make and type	:	AUTELEC VPF10
	No. of sensors recorders	:	6 sensors : 4 tanks 1 trip 1 flow 1 VPF 4B : recorder
28.1.11	Ezy Torque Gauge	:	One EZY Torque

28.2 Drilling Recorder (Permanent Record)

Make and type	:	GUERPILLON G1025
Quantity of pens	:	7
Parameters recorded	:	
- WOB/hook load	:	Yes
- ROP	:	Yes
- Rotary torque	:	Yes
- Pump pressure	:	Yes
- Pump strokes (2 pumps)	:	Yes
- Rotary RPM	:	Yes

28.3 Drift Recorder

Quantity	:	1 each
Make	:	TOTCO
Range	:	0-8° and 0-16°

- 28.4 **Kill/Choke Manifold Gauges**
Make and type : CAMERON
Vernier : 32
- 28.5 **Trip Tank Recorder**
: None
- 28.6 **Meteorological**
: Wind socks (one each at helideck and both crane).
Vessel motion (roll and pitch) "Sight Glasses".
Heave monitored at drill floor, not recorded.
- 28.7 **Navigational Equipment**
: See 12.0 of this equipment list.
- 28.8 **Scale**
: One bench platform dial scale
- 28.9 **Photocopier**
: 1 ea. Fuji Vivace 330
1 ea. Canon NP 1215

908058 129



Well Name : Baleen 2
Rig Name : Sedco 702
Engineer : Kohut/Westman

Date : 11-Oct-99
Casing Size : 30
Casing MD/TVD : 125.7

Table with 3 columns: Hole Geometry, Mud Properties, Gas Reading. Rows include Hole Size, Hole MD, Hole TVD, Hole Angle, Last Csg Size, Last Csg MD, Last Csg TVD, Mud Wt, Vis, PV, YP, WL, BHCT, BHST, Max Gas, Btms Up, Final BG.

Casing Summary

Table with 6 columns: Description, Wt (lb/ft), Grade, Conn, Length, Depth, mRT. Includes rows for Drill string and 30 casing.

Centralizers

Table with 4 columns: Manufacturer, Type, Quantity, Remark / Placement.

Lead Cement Slurry Details

Table with 6 columns: Weight (ppg), Vol (bbl), Mixwater (bbl), # Sacks, S. Vol(ft3/sk), Additives.

Tail Cement Slurry Details

Table with 6 columns: Weight (ppg), Vol (bbl), Mixwater (bbl), # Sacks, S. Vol(ft3/sk), Additives. Includes 15.8 av weight and Cacl2, 1% additive.

Top Up Cement Slurry Details

Table with 6 columns: Weight (ppg), Vol (bbl), Mixwater (bbl), # Sacks, S. Vol(ft3/sk), Additives.

Operation Description

Table with 6 columns: Circulation, Pre-Flush, Lead, Tail, Displacement. Rows for Volume (bbl) and Time (min).

Job Evaluation

Reciprocate : no
Full Returns : unknown
Cmt to Surface : yes
Bump Plug : no
Pressure Test: no
ECP : no

Remarks

Job went OK

Dril-Quip Australia
30" Casing String

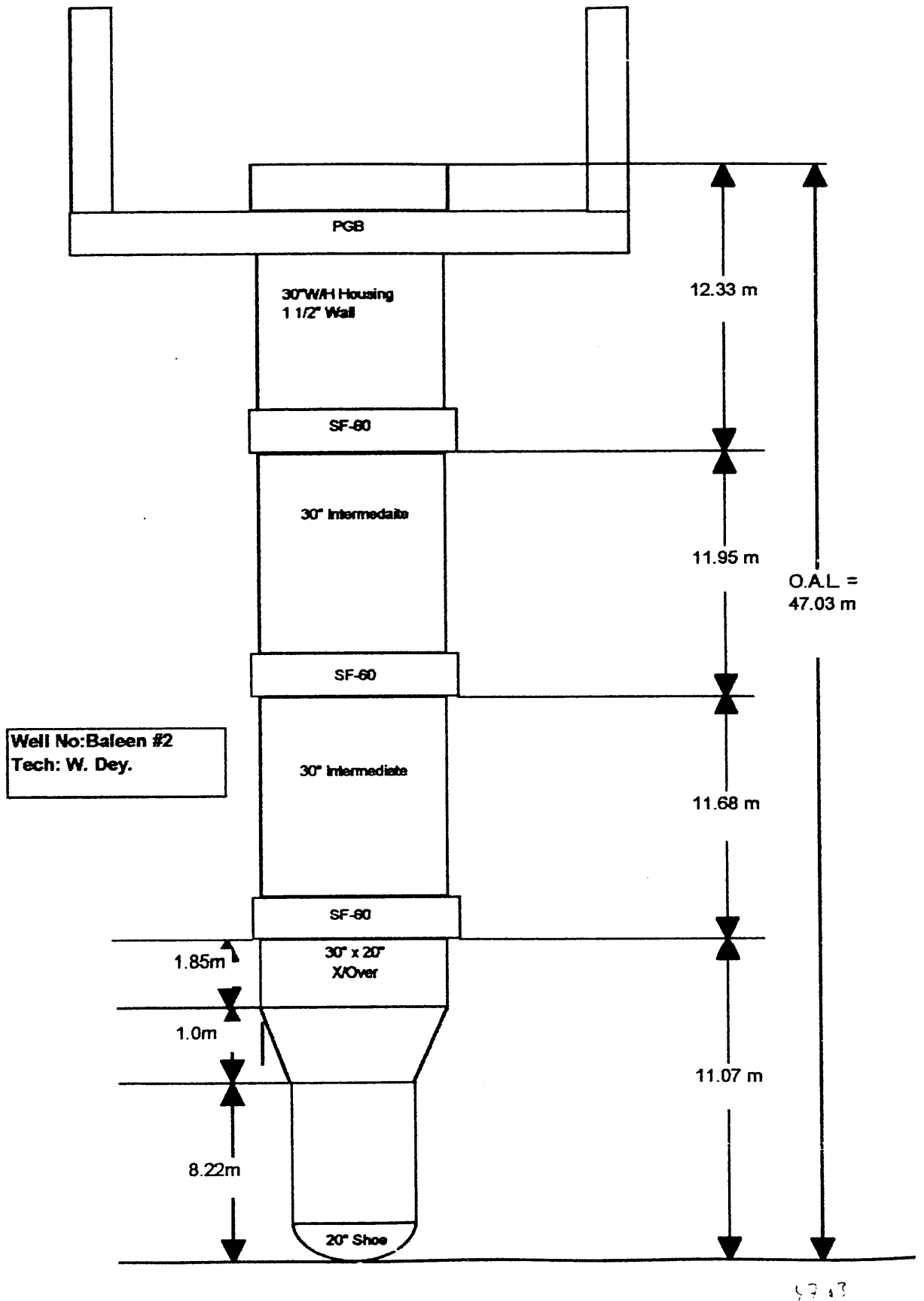

Dril-Quip Australia
Permanent Guide Base
(Remote- Tool Retrievable)

Max. O/D Of Guide Base = 9'-10 1/16"
Min. I/D Centre Ring = 34.50"

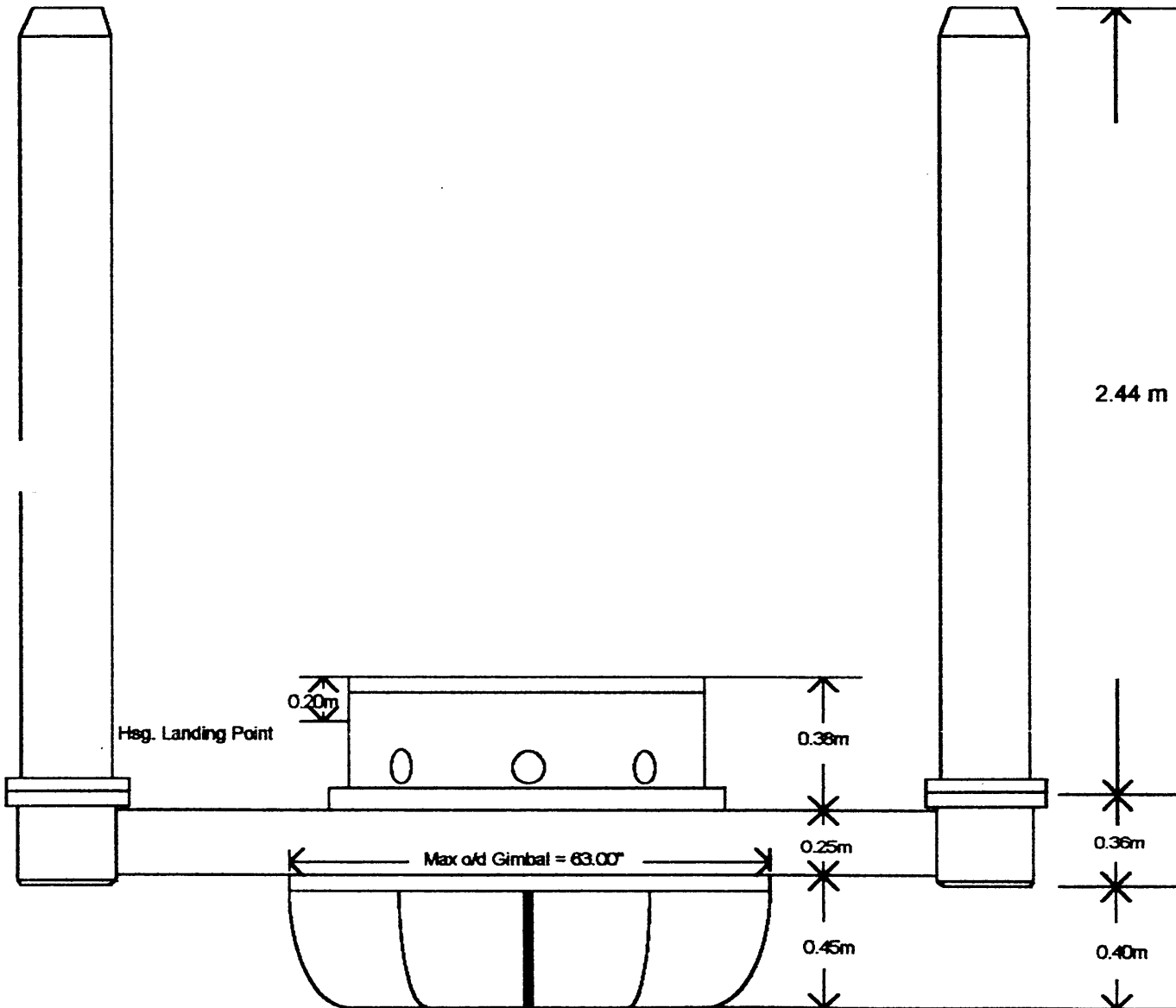

Part No. : 6-40004-02100
Serial No. : 2727
Company : Cultus
Well No. : Baleen #2
Date : 6/10/99
Service Tech. : W. Dey

Dril-Quip Australia
30" Wellhead Housing

Max. O/D Of Hsg. = 34.010"
Min. I/D Of Hsg = 26.970"

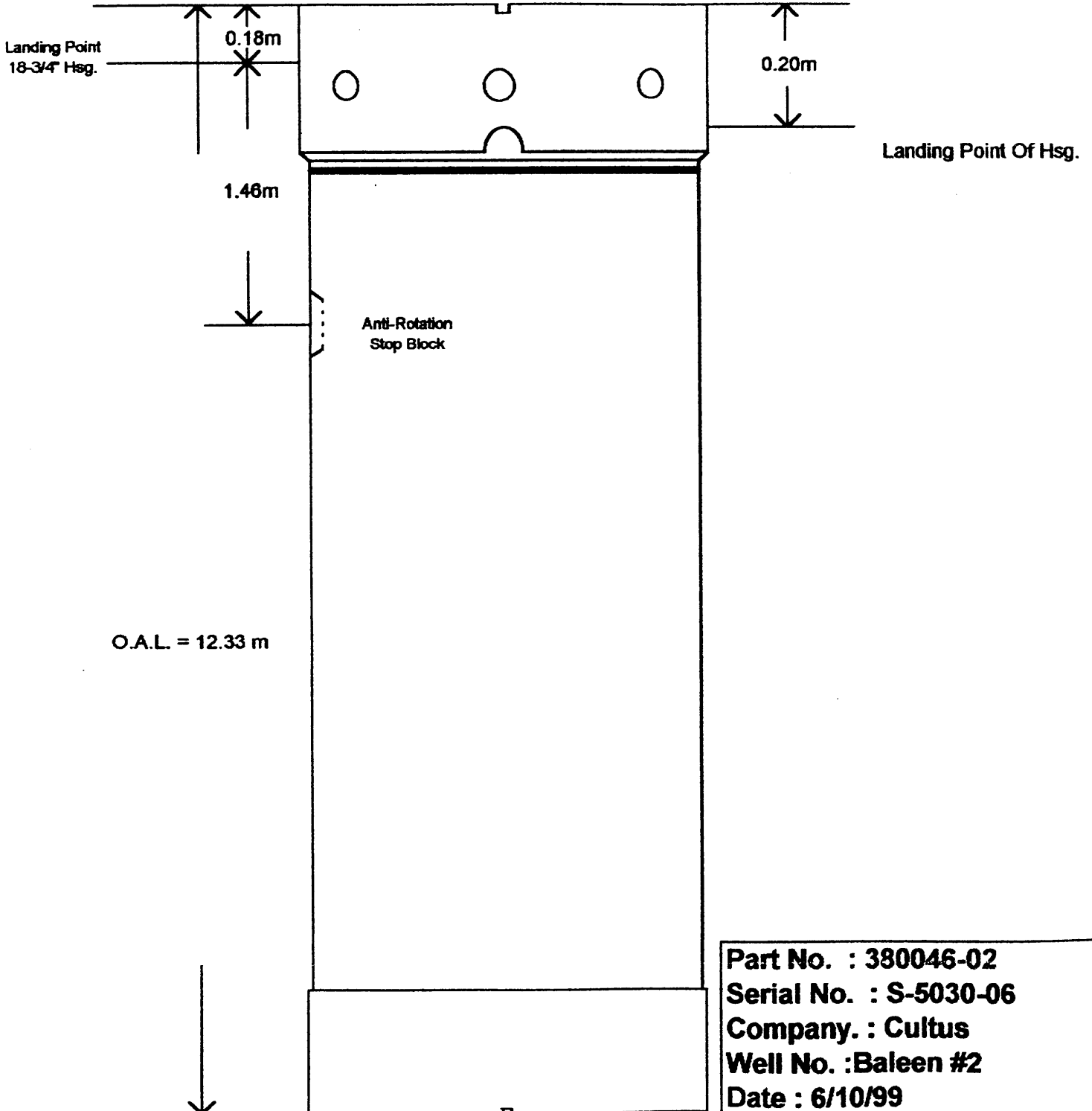

Part No. : 380046-02
Serial No. : S-5030-06
Company. : Cultus
Well No. : Baleen #2
Date : 6/10/99
Service Tech. :W. Dey

Cementing Service Report

903058 134

Schlumberger
Dowell

Customer				Job Number			
CULTUS PETROLEUM NL				4374603099			
Well		Location (legal)		Dowell Location		Job Start	
Baleen 2		Bass Strait		PAS		10/11/1999	
Field		Formation Name/Type		Deviation		Well MD	
Patricia Baleen Gasfield		Gippsland Limestone		0 °		127 m	
County		State/Province		BHP		Well TVD	
Victoria		Victoria		0 psi		126 m	
Rig Name		Drilled For		Service Via		Casing/Liner	
SEDCO 702		Gas		Offshore		Depth, m	
Offshore Zone		Well Class		Well Type		Size, in	
Bass Strait		New		Exploration		Weight, lb/ft	
Drilling Fluid Type		Max. Density		Plastic Viscosity		Grade	
Sea Water - Hyvis Weeps		8.53 lb/gal		0 cp		Thread	
Service Line		Job Type		Depth, m		Size, in	
Cementing		Cem Surface Casing		122.96		5	
Max. Allowed Tubing Pressure		Max. Allowed Ann. Pressure		Weight, lb/ft		Grade	
0 psi		0 psi		19.5		X 52	
Service Instructions		Wellhead Connection		Thread		Perforations/Open Hole	
30" Surface Casing		Camern Hub		4.5 IF		Top, m	
						Bottom, m	
						spf	
						No. of Shots	
						Total Interval	
						0 m	
						Diameter	
						0 in	
						Packer Type	
						Packer Depth	
						0 m	
						Treat Down	
						Displacement	
						10 bbl	
						Packer Type	
						Packer Depth	
						0 m	
						Tubing Vol.	
						Casing Vol.	
						Annular Vol.	
						Open Hole Vol	
						0 bbl	
						5.6 bbl	
						5.6 bbl	
						47 bbl	
						0 bbl	
Casing/Tubing Secured <input type="checkbox"/>		1 Hole Volume Circulated prior to Cementing <input type="checkbox"/>		Casing Tools		Squeeze Job	
Lift Pressure:		psi		Shoe Type:		Squeeze Type	
				Float			
Pipe Rotated <input type="checkbox"/>		Pipe Reciprocated <input type="checkbox"/>		Shoe Depth:		Tool Type:	
				126.86 m			
No. Centralizers:		Top Plugs:		Stage Tool Type		Tool Depth:	
0		0		0		0 m	
Cement Head Type:		Bottom Plugs:		Stage Tool Depth:		Tail Pipe Size:	
		0		0 m		0 in	
Job Scheduled For:		Arrived on Location:		Coil Type:		Tail Pipe Depth:	
		10/11/1999 09:45		0/11/1999 11:00		0 m	
				Coil Depth:		Sqz Total Vol:	
				m		0 bbl	
Time	Ann Vol	Density	Pressure	Toolflowrate			Message
24 hr clock	bbbl	ppg	psi	bpm			
09:59	0	0	0	0	0	0	START ACQUISITION
09:59	0	8.486	4.6	0	0	0	
10:00	0	8.484	4.6	0	0	0	
10:01	.0149	8.481	6.493	.2422	0	0	
10:02	3.387	8.556	80.89	4.39	0	0	
10:03	7.747	8.57	77.65	4.418	0	0	
10:04	0	8.543	5.285	0	0	0	Pressure Test Lines
10:05	0	8.522	6.671	0	0	0	
10:06	.1558	8.542	2167	0	0	0	
10:07	.1558	8.545	2148	0	0	0	
10:08	.1558	8.525	2134	0	0	0	
10:09	.1558	8.527	2130	0	0	0	
10:10	0	8.543	8.357	0	0	0	
10:11	0	8.54	4.609	0	0	0	Start Pumping Water
10:12	2.781	8.579	82.02	4.67	0	0	
10:13	7.436	8.561	83.97	4.713	0	0	
10:14	10.28	8.564	4.597	0	0	0	
10:14	0	8.584	4.6	0	0	0	Start Cement Slurry
10:15	0	8.607	4.919	0	0	0	
10:15	0	8.605	4.6	0	0	0	
10:16	0	10.15	9.17	0	0	0	
10:16	.0623	12.14	9.2	0	0	0	
10:17	.0623	13.89	9.2	0	0	0	
10:17	.0623	15.5	9.2	0	0	0	
10:18	.8623	16.02	170	5.658	0	0	
10:18	3.951	15.81	328.7	5.961	0	0	

Well	Field				Service Date	Customer	Job Number	Message
	Baleen #2		Patricia Baleen Gasfield					
Time	CanVol	Density	Pressure	TotalFlowrate				
24 hr clock	bbbl	ppg	psi	bpm				
10:19	6.753	15.97	345	5.966	0	0	0	
10:20	12.61	15.69	273.5	5.31	0	0	0	
10:20	15.47	15.78	263	5.31	0	0	0	
10:21	17.96	15.95	282.3	5.312	0	0	0	
10:21	20.91	16.06	345.5	5.966	0	0	0	
10:22	23.72	5.126	332.1	5.984	0	0	0	Slurry Viscus - Mix by Mud Balance
10:22	26.83	-2.127	314.7	5.981	0	0	0	
10:23	29.74	-1.695	296.9	5.984	0	0	0	
10:23	32.86	-2.773	280	5.976	0	0	0	
10:24	36.06	-3.089	389	6.989	0	0	0	
10:24	40.29	.1489	406.3	6.997	0	0	0	
10:25	43.11	-2.397	382.5	7.007	0	0	0	
10:25	47.14	-1.941	376.9	6.106	0	0	0	
10:26	49.49	11.58	290.3	5.377	0	0	0	
10:26	52.36	10.27	306.5	5.315	0	0	0	
10:27	55.1	-2.832	375.2	6.493	0	0	0	
10:27	58.37	8.439	416.8	6.982	0	0	0	
10:28	62	15.9	456.2	6.985	0	0	0	Slurry Thinned continue using Densistometer
10:28	65.39	15.87	452.2	6.523	0	0	0	
10:29	68.52	15.26	321.6	5.584	0	0	0	
10:29	71.04	16.33	341.2	5.325	0	0	0	
10:30	73.89	16.38	316.6	5.323	0	0	0	
10:30	77.38	16.33	295.2	5.322	0	0	0	
10:31	79.17	15.43	305.2	5.314	0	0	0	
10:31	81.67	17.62	323.1	5.335	0	0	0	
10:32	84.53	16.28	338.8	5.313	0	0	0	
10:32	87.2	15.66	298.1	5.309	0	0	0	
10:33	89.84	16.36	385.7	5.866	0	0	0	
10:33	93.15	16.53	384.7	5.991	0	0	0	
10:34	95.86	16.61	358	5.99	0	0	0	
10:34	98.67	16.57	394.4	5.982	0	0	0	
10:35	101.8	16.33	344.6	5.983	0	0	0	
10:35	105.1	16.21	337.4	5.993	0	0	0	
10:36	107.8	16.26	366	5.996	0	0	0	
10:36	111.4	16.14	297.5	5.354	0	0	0	
10:37	113.5	16.04	304.9	5.328	0	0	0	
10:37	116.3	16.27	305.9	5.329	0	0	0	
10:38	118.8	16.51	310.8	5.329	0	0	0	
10:38	121.7	16.37	299	5.328	0	0	0	
10:39	124.2	16.21	297.5	5.327	0	0	0	
10:39	127	15.99	282.9	5.345	0	0	0	
10:40	129.4	16.04	289.7	5.33	0	0	0	
10:40	132.3	15.86	282.9	5.336	0	0	0	
10:41	134.8	15.88	261	5.331	0	0	0	
10:41	137.7	17.68	278.8	5.337	0	0	0	
10:42	140.1	16.44	295.9	5.331	0	0	0	
10:42	142.4	16.48	290.8	5.331	0	0	0	
10:43	145.5	16.5	261.6	5.334	0	0	0	
10:43	148.7	15.8	282.3	5.345	0	0	0	
10:44	150.8	15.87	263	5.338	0	0	0	
10:44	154	15.97	273.9	5.337	0	0	0	
10:45	156.1	15.98	296.3	5.34	0	0	0	
10:45	158.8	15.93	288.3	5.345	0	0	0	
10:46	161.5	15.89	263.3	5.338	0	0	0	
10:46	164.4	15.89	287.4	5.35	0	0	0	
10:47	166.8	15.86	274.9	5.348	0	0	0	
10:47	169.6	15.8	281.9	5.35	0	0	0	
10:48	172.2	15.86	275.7	5.349	0	0	0	

Well		Field				Service Date		Customer		Job Number	
Baleen #2		Patricia Baleen Gasfield						CULTUS PETROLEUM NL		4374803088	
Time	CurVol	Density	Pressure	TotalWeight					Message		
24 hr clock	bbbl	ppg	psi	lbs							
10:48	175.1	15.91	268	5.348	0	0	0				
10:49	177.5	15.91	286.2	5.348	0	0	0				
10:49	180.3	15.9	263	5.35	0	0	0				
10:50	182.9	15.89	290.9	5.337	0	0	0				
10:50	186	15.85	275	5.35	0	0	0				
10:51	188.2	15.73	289.6	5.352	0	0	0				
10:51	191	15.71	77.87	1.096	0	0	0				
10:52	0	13.88	36.68	0	0	0	0	Start Displacement			
10:53	2.701	8.58	149.1	4.711	0	0	0				
10:54	7.373	8.536	87.2	4.712	0	0	0				
10:55	10.1	8.547	-1.772	0	0	0	0				
10:56	10.1	8.541	-13.8	0	0	0	0				
Post Job Summary											
Average Pump Rates, bpm						Volume of Fluid Injected, bbl					
Slurry	N2	Med	Maximum Rate	Total Slurry	Med	Spacer	N2				
0	0	0	0	191	0	20	0				
Treating Pressure Summary, psi						Breakdown Fluid					
Maximum	Final	Average	Slump Plug to	Breakdowns	Type	Volume	Density				
0	0	0	0	0		0 bbl	0 lb/gal				
Avg. N2 Percent	Designed Slurry Volume	Displacement	Mix Water Temp	<input checked="" type="checkbox"/> Cement Circulated to Surface? Volume		<input type="checkbox"/> Washed thru Perfs To					
0 %	176 bbl	10 bbl	80 °F	0 bbl		0 m					
Customer or Authorized Representative				Dowell Supervisor				<input type="checkbox"/> Circulation Lost <input checked="" type="checkbox"/> Job Completed			
Mr. Ray Kohut				MARK PETTENGELL							

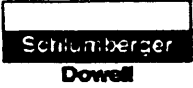

Cementing Job Report

PRISM V2.2

Well Baleen 2	Client Cultus Petroleum N.L
Field Patricia Baleen Gasfield	SIR No.
Country Australia	Job Date 10/11/1999 09:59:15 AM

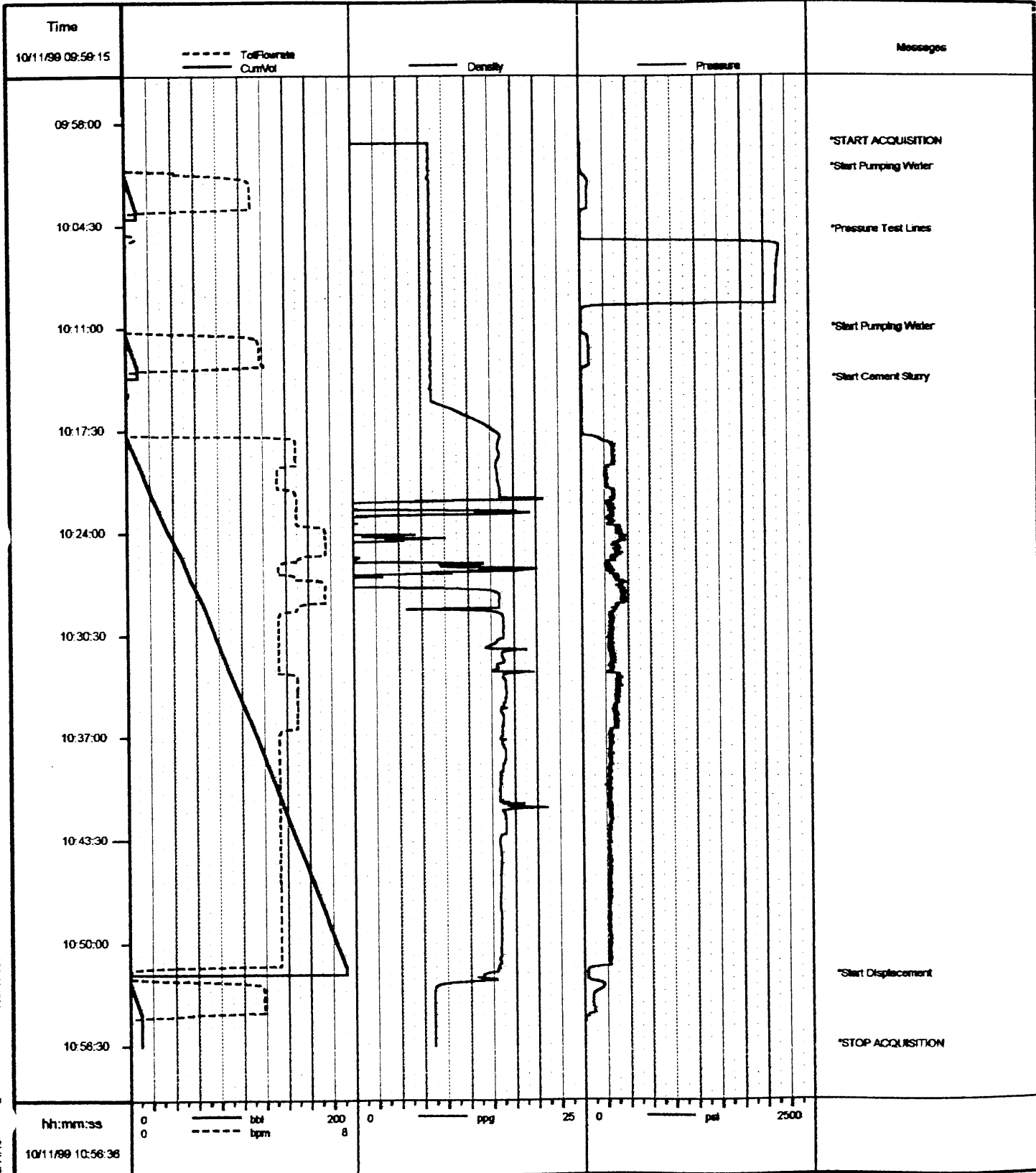

* Mark of Schlumberger



Cultus Group

CEMENTING REPORT

Well Name : Baleen 2
 Rig Name : Sedco 702
 Engineer : Kohut/Westman

Date : 13-Oct-99
 Casing Size : 95/8"
 Casing MD/TVD : 646.4

<u>Hole Geometry</u>		<u>Mud Properties</u>		<u>Gas Reading</u>	
Hole Size :	12 1/4	Mud Wt :	spud	Max Gas :	0
Hole MD :	650	Vis :	45	Btms Up :	0
Hole TVD :	650	PV :	28	Final BG :	0
Hole Angle :	0.25	YP :	62		
Last Csg Size :	30	WL :	nc		
Last Csg MD :	125.71	BHCT :			
Last Csg TVD :		BHST :			

Casing Summary

Description	Wt (lb/ft)	Grade	Conn	Length	Depth, mRT
					646.40
shoe joint	47	L80	lrc	12.61	633.79
intermediate jt	47	L80	lrc	11.99	621.80
float collar jt	47	L80	lrc	12.78	609.02
44jts	47	L80	lrc	521.02	88.00
xo & wellhead	47	L80	lrc	9.76	78.24
drillpipe	19.5	S135	4 1/2"IF	78.24	

Centralizers

Manufacturer	Type	Quantity	Remark / Placement
weatherford	bow	6	1st,2nd,3rd, center joint on stop collars, 4 next 4 collars next 4 over next casing collars

Lead Cement Slurry Details

Weight (ppg)	Vol (bbl)	Mixwater (bbl)	# Sacks	S. Vol(ft3/sk)	Additives
12.2	191.00	150	527	2.21	219 gals econolite

Tail Cement Slurry Details

Weight (ppg)	Vol (bbl)	Mixwater (bbl)	# Sacks	S. Vol(ft3/sk)	Additives
15.8	49.59	28	240	1.16	

Top Up Cement Slurry Details

Weight (ppg)	Vol (bbl)	Mixwater (bbl)	# Sacks	S. Vol(ft3/sk)	Additives

Operation Description

	Circulation	Pre-Flush	Lead	Tail	Displacement
Volume (bbl)	600	20	191	53	130.3
Time (min)	45	5	31	18	30

Job Evaluation

Reciprocate : no
 Full Returns : unknown
 Cmt to Surface : yes
 Bump Plug : no
 Pressure Test: no
 ECP : no

Remarks

circulate 2 circulations with seawater.
 no delivery or equipment problems.
 plug did not bump on theoretical volume
 displace casing with seawater.
 average torque 9850ft/lbs
 SSR plug shear press. Btm 1300psi, Top 3000psi

BALEEN #2 9-5/8" CASING RUNNING TALLY

Joint No.	Joint Length	Cumulative Length	Depth Landed	Capacity (bbls)	Displacement (bbls)	String Weight MT	Remarks 12 1/4" TD 650m.
Shoe	12.61	12.61	646.40				String wt is buoyed wt.
Intermediate	11.99	24.60	633.79				Bow centralisers-
Collar	12.78	37.38	621.80	0.0	0.00	1.798	2 meters above shoe
39	11.49	48.87	609.02	2.8	2.69	2.351	
40	11.86	60.73	597.53	5.6	3.35	2.922	on 1st, 2nd, 4th and 6th collar
41	11.79	72.52	585.67	8.4	3.99	3.489	
42	11.90	84.42	573.88	11.3	4.65	4.062	
43	11.87	96.29	561.98	14.1	5.30	4.633	
44	11.71	108.00	550.11	17.0	5.95	5.196	
45	11.80	119.80	538.40	19.8	6.60	5.764	
46	11.94	131.74	526.60	22.7	7.26	6.338	
47	11.81	143.55	514.66	25.5	7.91	6.906	
48	11.83	155.38	502.85	28.3	8.56	7.475	
49	11.90	167.28	491.02	31.2	9.21	8.048	
50	11.83	179.11	479.12	34.0	9.87	8.617	
51	11.90	191.01	467.29	36.9	10.52	9.190	
52	11.90	202.91	455.39	39.8	11.18	9.762	
53	11.85	214.76	443.49	42.6	11.83	10.332	
54	11.85	226.61	431.64	45.5	12.48	10.902	
55	11.85	238.46	419.79	48.3	13.14	11.472	
56	11.37	249.83	407.94	51.0	13.76	12.019	
57	11.91	261.74	396.57	53.9	14.42	12.592	
58	11.77	273.51	384.66	56.7	15.07	13.159	
59	11.77	285.28	372.89	59.5	15.71	13.725	
60	11.79	297.07	361.12	62.4	16.36	14.292	
61	11.86	308.93	349.33	65.2	17.02	14.863	
62	11.70	320.63	337.47	68.0	17.66	15.426	
63	11.60	332.23	325.77	70.8	18.30	15.984	
64	11.80	344.03	314.17	73.7	18.95	16.552	
65	11.54	355.57	302.37	76.4	19.59	17.107	
66	11.87	367.44	290.83	79.3	20.24	17.678	
67	12.00	379.44	278.96	82.2	20.90	18.255	
68	11.92	391.36	266.96	85.0	21.56	18.829	
69	11.80	403.16	255.04	87.9	22.21	19.396	
70	11.83	414.99	243.24	90.7	22.86	19.965	
71	11.80	426.79	231.41	93.5	23.51	20.533	
72	11.97	438.76	219.61	96.4	24.17	21.109	
73	11.88	450.64	207.64	99.3	24.82	21.681	
74	11.36	462.00	195.76	102.0	25.45	22.227	
75	11.88	473.88	184.40	104.8	26.10	22.799	
76	12.00	485.88	172.52	107.7	26.76	23.376	
77	11.98	497.86	160.52	110.6	27.42	23.952	
78	11.78	509.64	148.54	113.4	28.07	24.519	
79	11.89	521.53	136.76	116.3	28.73	25.091	
80	11.97	533.50	124.87	119.2	29.39	25.667	
81	12.04	545.54	112.90	122.1	30.05	26.246	
82	11.96	557.50	100.86	124.9	30.71	26.822	
Xo vam x Ltc	0.91	558.41	88.90	125.1	30.76	26.865	
W'hd. Hgr.	8.67	567.08	87.99	125.7	45.95	27.283	Below DATUM
Wellhead	1.09	568.17	79.32	125.7	46.03	27.335	
Rng tool.	0.44	568.61	78.23	125.7	46.07	27.356	Above DATUM
HWDP	83.70	652.31	77.79	130.6	52.85	31.383	DATUM at 78.2m RKB
		652.31	-5.91	130.6	52.85	31.383	
Stick up above RT		-5.91					

CASING RUN SUMMARY

Description from top to bottom	# jts.	Length (m)	From (m)	To (m)	Remarks
KB to landing shoulder (DATUM)	HWDP 9	83.7	78.24	-5.46	5.46m Stick-up.
DATUM to top of first joint	Wellhead	9.76	88.00	78.24	
9-5/8" 47# L80 BTC Casing	44	521.02	609.02	88.00	
Float Collar	1	12.78	621.80	609.02	
9-5/8" 47# L80 BTC Casing	1	11.99	633.79	621.80	Shoe Depth
Float Shoe	1	12.61	646.40	633.79	646.4m

Time Breakdown			Date: 12th October 1999
Start	Finish	Duration	Operation



Dril-Quip Australia
18-3/4" Wellhead housing

Max. O/D Of Hsg. = 31.25"
 Min. I/D Of Hsg = 17.562"

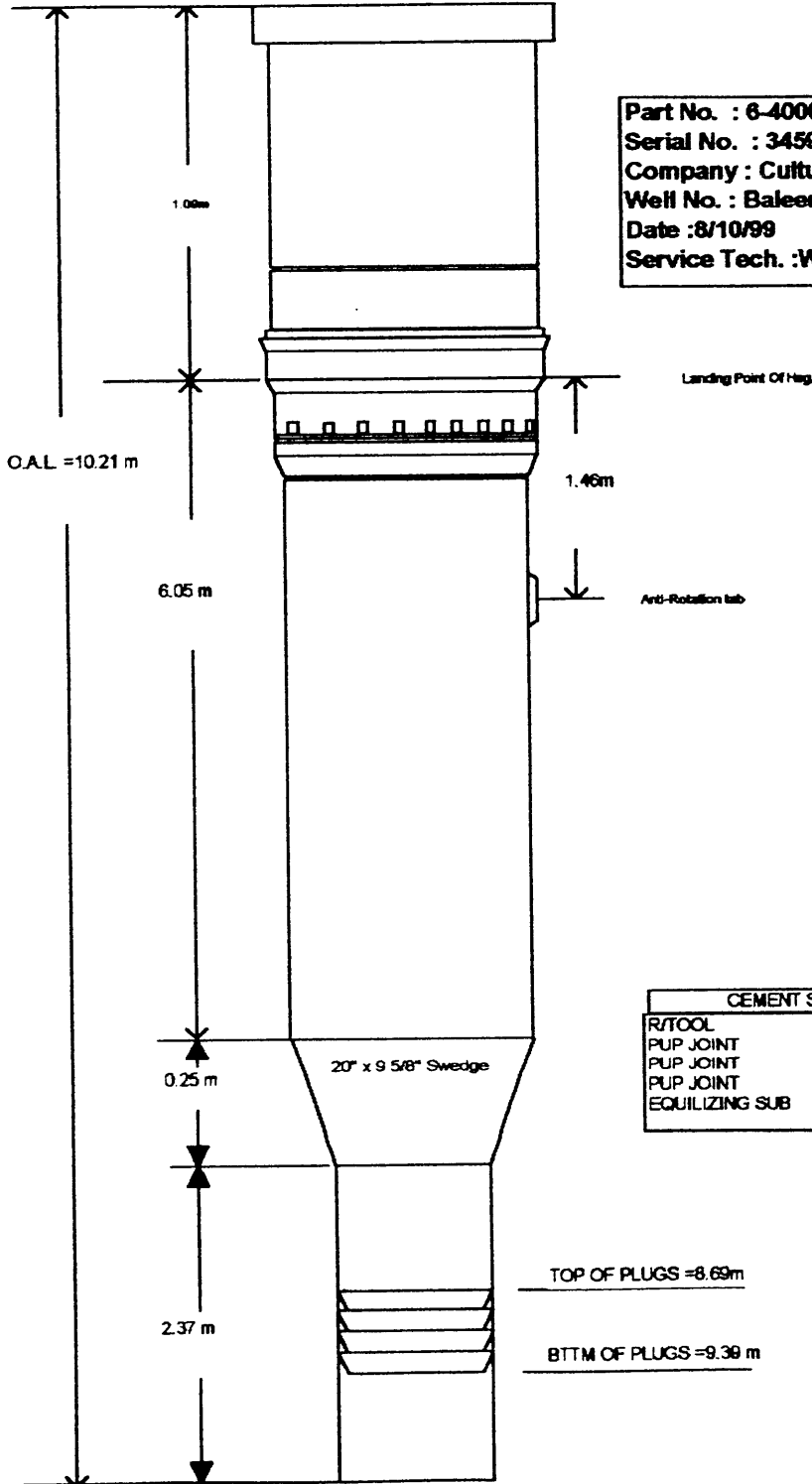

Part No. : 6-400046-02
 Serial No. : 3459-02
 Company : Cultus
 Well No. : Baleen #2
 Date : 8/10/99
 Service Tech. : W. DEY

CEMENT STRING	
R/TOOL	= 0.81 m
PUP JOINT	= 4.57 m
PUP JOINT	= 1.56 m
PUP JOINT	= 1.02 m
EQUILIZING SUB	= 0.73 m

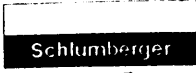

Cementing Service Report

908058 141

Schlumberger Dowell		Customer CULTUS PETROLEUM NL				Job Number 4374903100	
Well Baleen 2		Location (legal) Bass Strait		Dowell Location PAS		Job Start 10/13/1999	
Field Patricia Baleen Gasfield		Formation Name/Type Latrobe Group		Deviation 0 °	Bit Size 12.3 in	Well MD 650 m	Well TVD 650 m
County Victoria		State/Province Victoria		BHP 0 psi	BHST 105 °F	BHCT 92 °F	Pore Press. Gradient 0 psi/ft
Rig Name SEDCO 702	Drilled For Gas	Service Via Offshore		Casing/Liner			
Offshore Zone Bass Strait	Well Class New	Well Type Exploration		Depth, m 125	Size, in 30	Weight, lb/ft 275	Grade X 52
Drilling Fluid Type Sea Water - Hyvis Weeps	Max. Density 8.53 lb/gal	Plastic Viscosity 0 cp		Depth, m 646.4	Size, in 9.63	Weight, lb/ft 47	Grade N80
Service Line Cementing	Job Type Cem Intern Casing		Tubing/Drill Pipe				
Max. Allowed Tubing Pressure 0 psi	Max. Allowed Ann. Pressure 0 psi	Wellhead Connection Camem Hub		Depth, m 86.49	Size, in 5	Weight, lb/ft 19.5	Grade 4.5 IF
Service Instructions 9 5/8" Cementation.				Perforations/Open Hole			
Casing/Tubing Secured <input type="checkbox"/>	1 Hole Volume Circulated prior to Cementing <input type="checkbox"/>			Top, m 0	Bottom, m 0	spf 0	No. of Shots 0
Lift Pressure: psi	Pipe Rotated <input type="checkbox"/>	Pipe Reciprocated <input type="checkbox"/>		Total Interval 0 m	Diameter 0 in	Treat Down Drill Pipe	Displacement 128.5 bbl
No. Centralizers: 5	Top Plugs: 1	Bottom Plugs: 1		Packer Type 0 m	Packer Depth 0 m	Tubing Vol. 4.88 bbl	Casing Vol. 130 bbl
Cement Head Type: Double	Arrived on Location: 10/13/1999 02:15	Leave Location: 01/13/1999 04:45		Annular Vol. 250 bbl	Open Hole Vol bbl	Casing Tools	
Job Scheduled For:	Shoe Type: Float	Squeeze Job		Shoe Depth: 646.4 m	Tool Type:	Stage Tool Type	
Collar Type: Float	Collar Depth: 621.8 m	Sqz Total Vol: 0 bbl		Stage Tool Depth: 0 m	Tail Pipe Size: 0 in	Tail Pipe Depth: 0 m	
Time	Cem/Vol	Density	Pressure	Toolflowrate	Message		
24 hr clock	bbl	ppg	psi	bpm			
02:47	0	0	0	0	START ACQUISITION		
02:52	0	8.619	23	0	Start Pumping Water		
02:53	0	8.63	23	0			
02:54	2.027	8.613	62.74	3.568			
02:55	5.638	8.6	58.27	3.598			
02:56	9.301	8.609	61.36	3.663			
02:57	10.18	8.6	20.61	0			
02:58	10.18	8.598	23	0			
02:58	0	8.606	21.47	0	Pressure Test Lines		
02:59	.0542	8.605	2821	0			
03:00	0	8.602	2818	0			
03:01	0	8.6	2392	0			
03:02	0	8.612	13.8	0			
03:04	0	8.596	22.73	0	Start Pumping Water		
03:05	3.884	8.604	98.52	4.86			
03:06	8.798	8.603	94.47	4.896			
03:06	9.944	8.594	14.65	0			
03:07	0	8.588	13.8	0	Release Ball from Cmt Head		
03:08	0	8.592	13.8	0			
03:09	0	8.601	13.8	0			
03:10	0	8.602	18.4	0	Start Pumping Water		
03:11	.1891	8.612	18.49	.5025			
03:12	.4439	8.614	22.98	.5046			
03:13	.948	8.61	26.67	.5002			
03:14	1.447	8.61	42.51	.4952			
03:15	1.849	8.613	1300	.1153	Shear Bottom Plug		

Well		Field			Service Date		Customer		Job Number	
Baleen #2		Patricia Baleen Gasfield					CULTUS PETROLEUM NL		4374903100	
Time	CurVol	Density	Pressure	ToolFlowrate				Message		
24 hr clock	bbl	ppg	psi	bpm						
03:15	1.855	8.606	18.48	0	0	0	0			
03:16	1.855	8.606	18.48	0	0	0	0	Start Mixing Lead Slurry @ 12.5ppg		
03:16	1.855	8.602	18.4	0	0	0	0			
03:17	1.862	8.63	18.4	0	0	0	0			
03:18	1.872	9.181	18.4	0	0	0	0			
03:19	1.92	10.96	21.93	.0527	0	0	0			
03:20	3.165	12.76	225.1	7.505	0	0	0			
03:21	8.879	12.66	201.5	5.757	0	0	0			
03:22	15.75	12.87	262.8	6.768	0	0	0			
03:23	22.56	12.63	283.9	6.749	0	0	0			
03:24	29.37	13.23	276.6	6.75	0	0	0			
03:25	36.16	12.85	288.6	6.752	0	0	0			
03:26	42.96	12.63	280.1	6.754	0	0	0			
03:27	49.77	12.61	273.8	6.753	0	0	0			
03:28	56.69	12.73	300.4	6.924	0	0	0			
03:29	63.67	12.64	305.2	6.933	0	0	0			
03:30	70.65	12.6	292.5	6.923	0	0	0			
03:31	77.62	12.58	288.8	6.922	0	0	0			
03:32	84.7	12.69	358	7.799	0	0	0			
03:33	92.62	12.67	358.1	7.874	0	0	0			
03:34	99.92	12.61	290.8	6.962	0	0	0			
03:35	106.9	12.54	295.6	6.957	0	0	0			
03:36	114	12.67	341.1	7.652	0	0	0			
03:37	121.9	12.55	359.8	7.888	0	0	0			
03:38	129	12.74	302.3	6.955	0	0	0			
03:38	132.5	12.64	300.7	6.967	0	0	0			
03:39	136	12.55	671.2	6.876	0	0	0			
03:39	139.5	12.6	295.6	6.969	0	0	0			
03:40	143.2	12.65	363.7	7.879	0	0	0			
03:40	147.1	12.67	349.8	7.907	0	0	0			
03:41	151.1	12.65	363.3	7.892	0	0	0			
03:41	155.1	12.59	313.6	7.219	0	0	0			
03:42	158.6	12.57	290.5	6.974	0	0	0			
03:42	162.1	12.6	289.7	6.966	0	0	0			
03:43	165.6	12.67	286.1	6.971	0	0	0			
03:43	169.1	12.65	289.3	6.976	0	0	0			
03:44	172.6	12.53	280.5	6.969	0	0	0			
03:44	176.1	12.53	290.7	6.974	0	0	0			
03:45	179.7	12.56	286.2	6.966	0	0	0			
03:45	183.2	12.51	275.7	6.976	0	0	0			
03:46	187	12.54	363.7	7.899	0	0	0			
03:46	191	12.39	357.6	7.917	0	0	0			
03:47	194.5	12.39	357.6	7.917	0	0	0	Start Mixing Tail Slurry @ 15.8ppg		
03:47	3.973	12.81	241.7	6.368	0	0	0			
03:48	3.973	12.81	241.7	6.368	0	0	0			
03:49	13.21	12.35	102.8	1.317	0	0	0			
03:50	13.28	14.74	64.4	0	0	0	0			
03:51	17.2	15.77	217.4	4.459	0	0	0			
03:52	21.7	16.01	215.7	4.469	0	0	0			
03:53	26.95	13.44	227.2	5.551	0	0	0			
03:54	32.53	13.2	209.9	5.538	0	0	0			
03:55	35.23	14.41	182.7	4.258	0	0	0			
03:56	39.2	16.04	211	3.914	0	0	0			
03:57	43.14	16.49	194.7	3.919	0	0	0			
03:58	47.09	16.49	172.7	3.91	0	0	0			
03:59	50.1	16.49	130.6	2.85	0	0	0			
04:00	52.95	16.18	117.2	2.148	0	0	0			
04:00	53.08	16.18	117.2	2.148	0	0	0			

Well		Field				Service Date	Customer	Job Number
Baleen #2		Patricia Baleen Gasfield					CULTUS PETROLEUM NL	4374803100
Time	Conn/Well	Density	Pressure	Total Flowrate				Message
24 hr clock	bbbl	ppg	psi	bpm				
04:01	0	2.169	73.6	0	0	0	0	Release Dart
04:02	0	2.271	73.6	0	0	0	0	
04:03	0	2.773	73.6	0	0	0	0	
04:04	0	2.897	77.69	0	0	0	0	
04:05	0	2.912	76.48	0	0	0	0	Start Pumping Water
04:06	5.655	9.409	117.6	2.196	0	0	0	
04:07	2.818	8.667	84.74	2.239	0	0	0	
04:08	4.04	8.654	69	.9295	0	0	0	
04:08	4.392	8.661	3000	.1622	0	0	0	Shear Top Plug
04:09	4.392	8.661	6.022	.1622	0	0	0	Start Displacement
04:09	.4854	8.643	73.34	4.022	0	0	0	
04:10	3.178	8.653	112.2	5.769	0	0	0	
04:11	8.996	8.654	118.3	5.778	0	0	0	
04:12	15.32	8.646	172.6	7.308	0	0	0	
04:13	22.86	8.64	242.8	7.532	0	0	0	
04:14	30.45	8.64	256.7	7.525	0	0	0	
04:15	38.03	8.64	260.4	7.525	0	0	0	
04:16	45.61	8.639	268.4	7.521	0	0	0	
04:17	53.18	8.639	305.3	7.51	0	0	0	
04:18	60.74	8.639	323.9	7.508	0	0	0	
04:19	68.29	8.639	337.3	7.489	0	0	0	
04:20	75.84	8.639	345.1	7.488	0	0	0	
04:21	87.14	8.643	384.8	7.468	0	0	0	
04:22	90.9	8.639	412.9	7.473	0	0	0	
04:23	98.42	8.646	455.2	7.452	0	0	0	
04:24	105.9	8.643	489.4	7.446	0	0	0	
04:25	113.4	8.644	530.8	7.427	0	0	0	
04:26	120.3	8.646	337.4	2.94	0	0	0	
04:27	123.3	8.646	324	1.733	0	0	0	
04:28	124.1	8.646	336.2	1.458	0	0	0	
04:29	125.5	8.646	327.4	1.378	0	0	0	
04:30	126.9	8.646	340.1	1.373	0	0	0	
04:31	128.3	8.646	357	1.369	0	0	0	
04:32	128.5	8.646	320.8	0	0	0	0	
04:33	128.5	8.646	322	0	0	0	0	
04:34	129.2	8.646	348.7	.8747	0	0	0	
04:35	130.1	8.646	356	.8752	0	0	0	
04:36	130.3	8.646	340.1	0	0	0	0	
04:37	130.3	8.646	9.214	0	0	0	0	
04:38								Bleed Off - Shoe Holding

Post Job Summary

Average Pump Rates, bpm				Volume of Fluid Injected, bbl			
Slurry	N2	Mud	Maximum Rate	Total Slurry	Mud	Spacer	N2
0	0	0	0	247.5		20	0
Treating Pressure Summary, psi				Breakdown Fluid			
Maximum	Final	Average	Bump Plug to	Breakdown	Type	Volume	Density
0	0	0	0	0		0 bbl	0 lb/gal
Avg. N2 Percent	Designed Slurry Volume	Displacement	Mix Water Temp	<input type="checkbox"/> Cement Circulated to Surface? Volume 0 bbl <input type="checkbox"/> Washed Thru Perfs To 0 m			
0 %	236 bbl	130.28 bbl	80 °F				
Customer or Authorized Representative			Dowell Supervisor			<input type="checkbox"/> Circulation Lost <input checked="" type="checkbox"/> Job Completed	
Mr. Ray Kohut			MARK PETTENGELL				

Well Baleen 2	Client Cultus Petroleum N.L.
Field Patricia Baleen Gasfield	SIR No.
Country Australia	Job Date 10/13/1999 02:47:57 AM

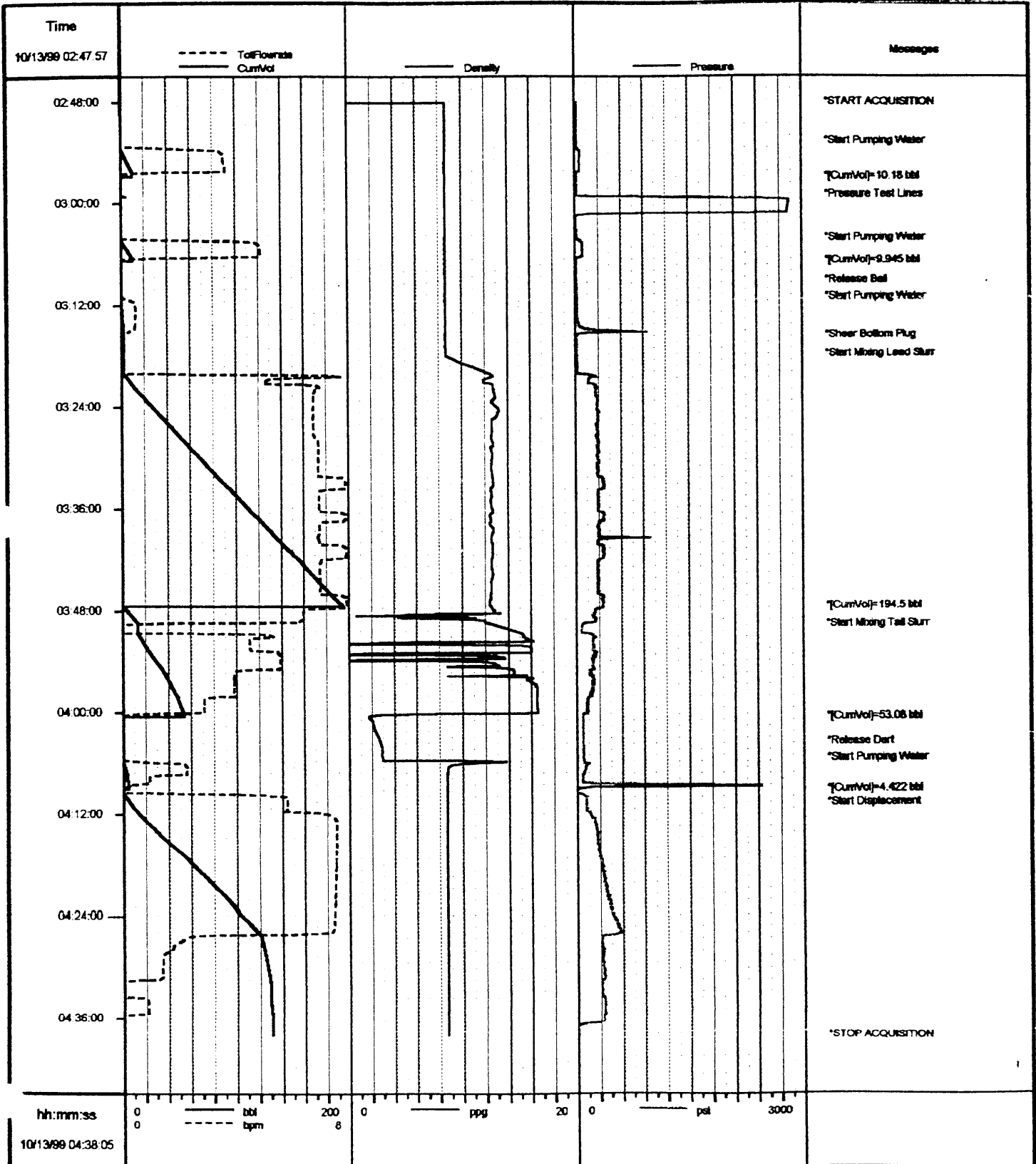

Job: cu958c

10/13/1999

* Mark of Schlumberger



Cementing Service Report

Dowell

Customer: **CULTUS PETROLEUM NL**
Job Number: **4374903103**

Well Baleen 2		Location (Legal) Bass Strait		Dowell Location PAS		Job Start 10/18/1999				
Field Patricia Baleen Gasfield		Formation Name/Type Latrobe Group		Deviation °		BN Size in	Well MD 925 m	Well TVD 925 m		
County		State/Province Victoria		BHP 0 psi	BHST 105 °F	BHCT 92 °F	Pore Press. Gradient 0 psi/ft			
Rig Name SEDCO 702		Drilled For Gas	Service Via Offshore			Casing/Liner				
Offshore Zone Bass Strait		Well Class New	Well Type Exploration			Depth, m 125	Size, in 30	Weight, lb/R 275	Grade X 52	Thread SF-60
Drilling Fluid Type KCL Polymer		Max. Density 10.1 lb/gal	Plastic Viscosity 0 cp			Depth, m 646.4	Size, in 9.63	Weight, lb/R 47	Grade N80	Thread LTC
Service Line Cementing		Job Type Pumping Cementing			Tubing/Drill Pipe					
Max. Allowed Tubing Pressure 0 psi		Max. Allowed Ann. Pressure 0 psi		Wellhead Connection Camern Hub	Perforations/Open Hole					
Service Instructions P+A Plugs 1 - 3					Top, m	Bottom, m	spf	No. of Shots	Total Interval	
					0	0	0	0	0 m	
					0	0	0	0	Diameter	
					0	0	0	0	0 in	
					Treat Down Drill Pipe	Displacement bbl	Packer Type		Packer Depth m	
Tubing Vol bbl		Casing Vol bbl		Annular Vol bbl	Open Hole Vol bbl					
Casing/Tubing Secured <input type="checkbox"/>		1 Hole Volume Circulated prior to Cementing <input type="checkbox"/>			Casing Tools		Squeeze Job			
Lift Pressure: psi				Shoe Type:	Squeeze Type					
Pipe Rotated <input type="checkbox"/>		Pipe Reciprocated <input type="checkbox"/>			Shoe Depth: m	Tool Type:				
No. Centralizers:		Top Plugs:	Bottom Plugs:			Stage Tool Type	Tool Depth: 0 m			
Cement Head Type:				Stage Tool Depth: m	Tail Pipe Size: 0 in					
Job Scheduled For:		Arrived on Location: 10/19/1999 09:50		Leave Location: 01/19/1999 10:35			Collar Type:	Tail Pipe Depth: 0 m		
				Collar Depth: m	Sqz Total Vol: 0 bbl					
Time	CumVol	Density	Pressure	ToolFlowrate					Message	
24 hr clock	bbl	ppg	psi	bpm						
06:46	0	0	0	0	0	0	0	0	START ACQUISITION	
06:46	0	8.433	18.44	0	0	0	0	0	PLUG 1	
06:47	0	8.433	18.44	0	0	0	0	0	Start Pumping Water	
06:52	0	8.433	18.44	0	0	0	0	0	Pressure Test Lines	
06:56	5.908	8.44	118.7	2.697	0	0	0	0		
06:58	5.908	8.44	118.7	2.697	0	0	0	0	[CumVol]=10.39 bbl	
06:58	5.908	8.44	118.7	2.697	0	0	0	0	Reset Volume	
06:58	5.908	8.44	118.7	2.697	0	0	0	0	Start Cement Slurry	
07:06	13.86	18.96	117.2	3.147	0	0	0	0		
07:11	13.86	18.96	117.2	3.147	0	0	0	0	[CumVol]=28.85 bbl	
07:11	13.86	18.96	117.2	3.147	0	0	0	0	Reset Volume	
07:11	13.86	18.96	117.2	3.147	0	0	0	0	Start Pumping Water	
07:12	13.86	18.96	117.2	3.147	0	0	0	0	[CumVol]=.959 bbl	
07:12	13.86	18.96	117.2	3.147	0	0	0	0	Reset Volume	
07:12	13.86	18.96	117.2	3.147	0	0	0	0	Start Displacement	
07:16	20.76	13.24	133.9	5.724	0	0	0	0		
07:20	20.76	13.24	133.9	5.724	0	0	0	0	[CumVol]=40.58 bbl	
07:20	20.76	13.24	133.9	5.724	0	0	0	0	Reset Volume	
08:32	0	-6.25	-3877	0	0	0	0	0	PLUG 2	
08:32	0	-6.25	-3877	0	0	0	0	0	Start Pumping Water	
08:41	0	-6.25	-3877	0	0	0	0	0	[CumVol]=9.975 bbl	
08:41	0	-6.25	-3877	0	0	0	0	0	Reset Volume	
08:41	0	-6.25	-3877	0	0	0	0	0	Start Cement Slurry	
08:42	0	7.187	36.88	0	0	0	0	0		
08:52	0	9.213	38.28	0	0	0	0	0		
09:02	9.451	11.73	28.36	0	0	0	0	0		

Well		Field			Service Date		Customer		Job Number	
Baleen #2		Patricia Baleen Gasfield					CULTUS PETROLEUM NL		4374903103	
Time	CumVol	Density	Pressure	Total Flowrate			Message			
24 hr clock	bbl	ppg	psi	bpm						
09:12	9.452	8.167	32.24	0	0	0	0			
09:22	31.81	16	86.64	2.784	0	0	0			
09:27	31.81	16	86.64	2.784	0	0	0	[CumVol]=47.48 bbl		
09:27	31.81	16	86.64	2.784	0	0	0	Reset Volume		
09:27	31.81	16	86.64	2.784	0	0	0	Start Pumping Water		
09:29	31.81	16	86.64	2.784	0	0	0	[CumVol]=1.181 bbl		
09:29	31.81	16	86.64	2.784	0	0	0	Reset Volume		
09:29	31.81	16	86.64	2.784	0	0	0	Start Displacement		
09:32	11.98	13.35	106.5	5.228	0	0	0			
09:36	11.98	13.35	106.5	5.228	0	0	0	Reset Volume		
09:36	11.98	13.35	106.5	5.228	0	0	0	[CumVol]=29.65 bbl		
22:33	11.98	13.35	106.5	5.228	0	0	0	PLUG 3		
22:33	0	-6.25	-3877	0	0	0	0	Start Pumping Water		
22:36	0	-6.25	-3877	0	0	0	0	Pressure Test Lines		
22:43	8.333	8.385	74.62	4.257	0	0	0			
22:44	8.333	8.385	74.62	4.257	0	0	0	Reset Volume		
22:44	8.333	8.385	74.62	4.257	0	0	0	[CumVol]=9.667 bbl		
22:44	8.333	8.385	74.62	4.257	0	0	0	Start Cement Slurry		
22:52	8.333	8.385	74.62	4.257	0	0	0	Reset Volume		
22:52	8.333	8.385	74.62	4.257	0	0	0	[CumVol]=13.83 bbl		
22:52	8.333	8.385	74.62	4.257	0	0	0	Start Displacement		
22:53	3.375	15.25	74.3	4.143	0	0	0			
22:55	3.375	15.25	74.3	4.143	0	0	0	[CumVol]=5.008 bbl		
22:55	3.375	15.25	74.3	4.143	0	0	0	Reset Volume		

Post Job Summary

Average Pump Rates, bpm				Volume of Fluid Injected, bbl			
Slurry	N2	Mud	Maximum Rate	Total Slurry	Mud	Spacer	N2
0	0	0	0				0
Treating Pressure Summary, psi				Breakdown Fluid			
Maximum	Final	Average	Bump Plug to Breakdown	Type	Volume	Density	
0	0	0	0		bbl	0 lb/gal	
Avg. N2 Percent	Designed Slurry Volume	Displacement	Mix Water Temp	<input type="checkbox"/> Cement Circulated to Surface? Volume 0 bbl <input type="checkbox"/> Washed Thru Perfs To 0 m			
0 %	bbl	bbl	80 °F				
Customer or Authorized Representative			Dowell Supervisor		<input type="checkbox"/> Circulation Lost <input checked="" type="checkbox"/> Job Completed		
Mr. Ray Kohut			GEORGE MURPHY				

Section Number
Dowell

Cementing Job Report

Well Baleen 2 P+A Plug 1	Client Cultus Petroleum N.L.
Field Patricia Baleen Gasfield	SIR No.
Country Australia	Job Date 10/18/1999 06:46:56 AM

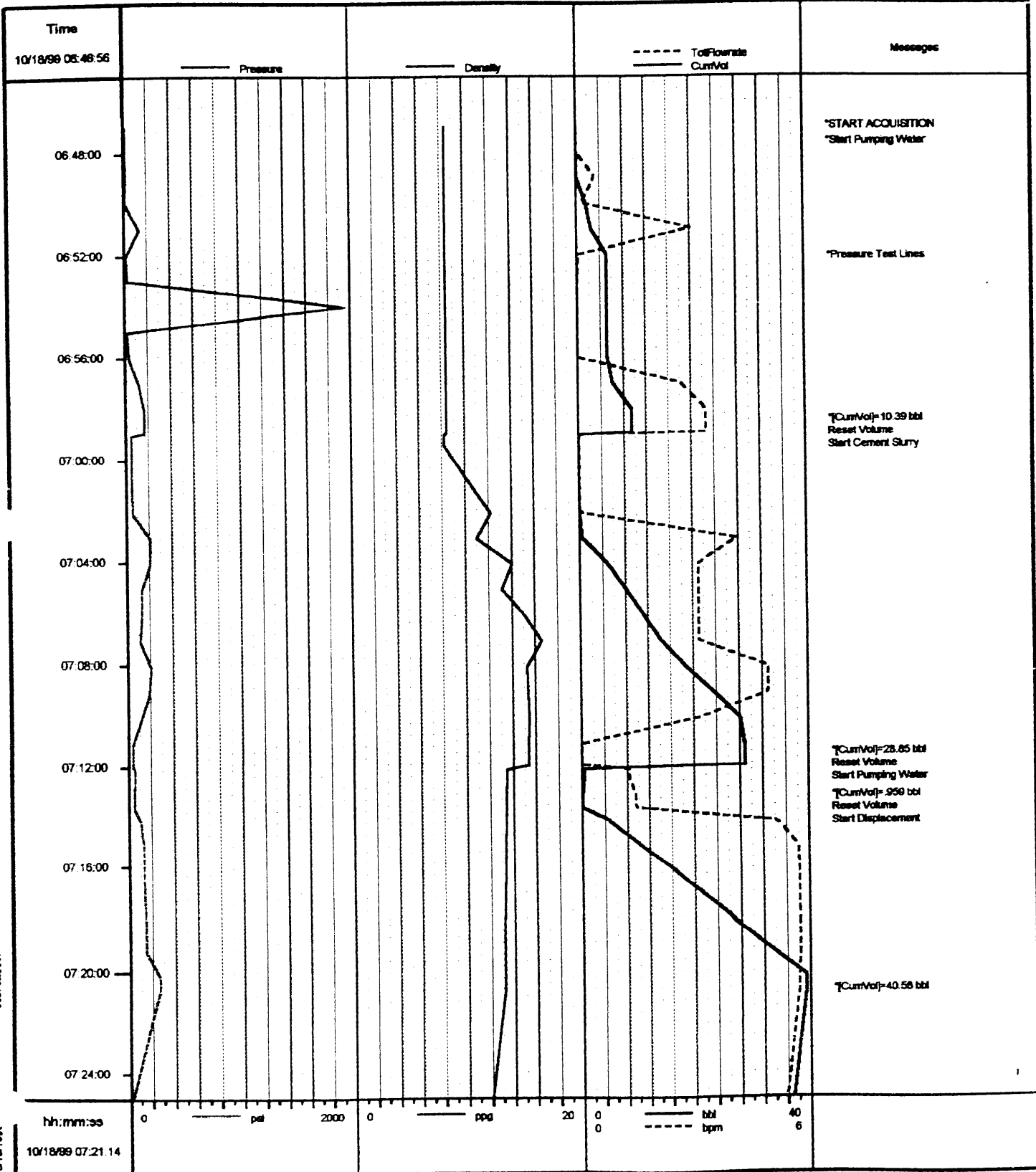

Job: cu6681
10/18/1999

* Mark of Schlumberger

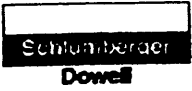

Cementing Job Report

PRISM V2.2

Well Baleen 2 P+A Plug 2	Client Cultus Petroleum N.L.
Field Patricia Baleen Gasfield	SIR No.
Country Australia	Job Date 10/18/1999 08:32:00 AM

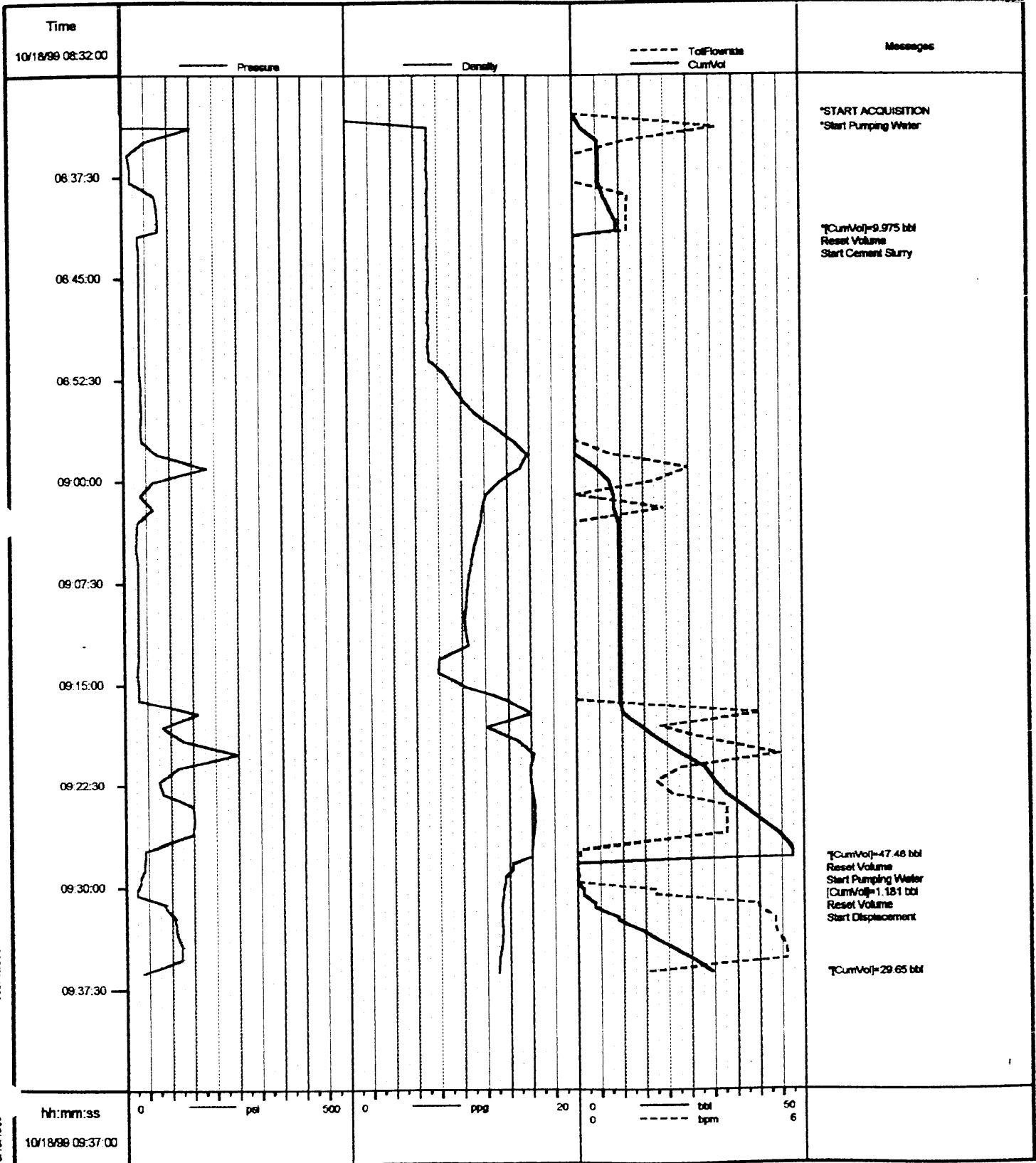

* Mark of Schlumberger



Cementing Job Report

908058 150

PRISM V2.2

Well	Baleen 2 P+A Plug 3	Client	Cultus Petroleum N.L.
Field	Patricia Baleen Gasfield	SIR No.	
Country	Australia	Job Date	10/18/1999 10:33:00 PM

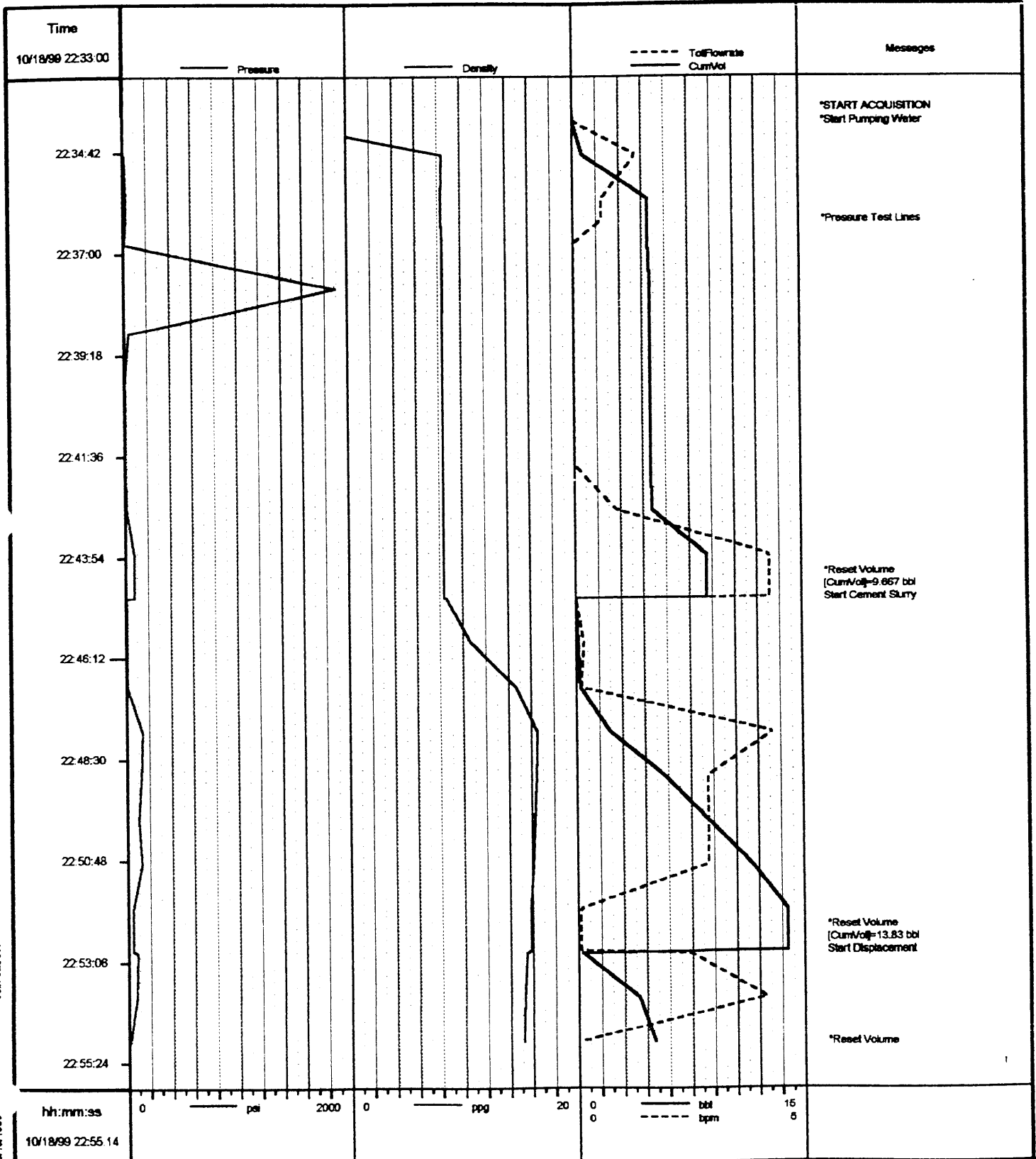

Job: cul9581
10/18/1999

* Mark of Schlumberger

BIT RECORD
Baleen #2

Bit No.	Size (ins)	Make	Type	IADC Code	Serial No.	Jets 32nds	Depth Out (m)	Drilled (m)	Hrs	ROP (m/hr)	WOB (m.kg)	RPM	Press (psi)	Pump (gpm)	MW (sg)	Dev (deg)	Grade						
																	I	O	D1	L	B	G	D2
Rr1	26	Reed	Y11	111	Kw0659	24x3	126	45	3¼	14	5	70	1000	1300	8.6	3/4	1	1	wt	a	e	1	td
Rr1	36		HO	111	020300003	20x3	123	42	3¼	14	5	70	1000	1300	8.6	¾	1	1	wt	a	e	1	TD
2rrr	17½	Smith	MSDSHQc	137	LF9226	24x3	126	Ream	cmt								1	1	wt	a	e	1	wt td
3	12¼	Hycalog	DS40	PDC	10452	18x5	650	524	7.5	68.9	10	130	1150	1032	8.6	1/4	1	1	ct	A	x	1	er td
4	8½	Reed	MHT13G	137	KT2055	18 X 3	746	96	9.6	10	10/15	110	1600	634	10.1		2	3	wt	o	E	1	wt cp
5	8½	DBS	CD73	CH	79709238	7	762.3	16.3	1.2	13.58	5	70	550	190	10.1		1	2	ct	A	X	1	bp ¹⁰⁰
5rr	8½	DBS	CD73	CH	79709238	7	780	17.7	1.2	14.75	5	70	550	190	10.1		1	2	ct	A	X	1	bp ^{88%}
6	8½	Reed	EHP43	437	9D4605	14 X 3	895	115	5.1	22.5	15	90	2300	450	10.1	1/2	1	1	Nil	A	E	1	Nil Td

**CULTUS PETROLEUM N.L.
DRILLING FLUID RECAP
BALEEN-2
BASS STRAIT, VICTORIA**



Prepared by: Tony Kowalski, Innes Macleod

Date: October, 1999

Table Of Contents

1. WELL SUMMARY
2. COST SUMMARY
3. PERFORMANCE SUMMARY
4. INTERVAL-1
5. INTERVAL-2
6. INTERVAL-3
7. APPENDICES
 - Deviation Data
 - Caliper Log Data
8. GRAPHS
 - Well Progress & Drilling Fluid Cost
 - Density, HPHT Filtrate & Low Gravity Solids
 - 6 RPM Reading, Plastic Viscosity & Yield Point
9. POST WELL AUDIT
 - WELL SUMMARY
 - TOTAL MATERIAL CONSUMPTION
 - INTERVAL SUMMARY
 - INTERVAL MATERIAL CONSUMPTION
 - INTERVAL MUD CONSUMPTION
 - DAILY MUD VOLUME RECORD
 - MUD PROGRAM EXCEPTIONS REPORT
 - MUD PROPERTY RECAP
 - DAILY OPERATIONS LOG
 - BIT & HYDRAULIC RECORD
10. DAILY MUD REPORTS

1.

WELL SUMMARY

1.1 Well Data

Well Name	:	Baleen-2
Operator	:	Cultus Petroleum N.L.
Well Type	:	Vertical
Bottom Hole Temperature	:	48° C
Location	:	Bass Strait, Victoria
Contractor / Rig	:	Sedco 702
Start Date (Abandonment)	:	9 October, 1999
Spud Date	:	11 October, 1999
RKB to Seabed	:	80.7 m
RKB to MSL	:	25.9 m
Total Depth	:	895 m
Date TD Reached	:	16 October, 1999
Total Days Drilling	:	5 days
Date Released	:	19 October, 1999
Total Days on Well	:	11 days

1.2 Formation Tops

Formation	MD (m)	TVD (m)	Inclination (deg)
Gippsland Limestone	81	81	0.5
Lakes Entrance	724	724	0.25
Gumard	748	748	0.25
Coarse Clastics	792	792	0.25
Strzelecki	872	872	0.25
Total Depth	895	895	0.25

1.3 Casing Program

30"	Structural Casing	@	125.7 m
9 ⁵ / ₈ "	Surface Casing	@	646.4 m

1.4 Personnel

Drilling Supervisors	:	Ray Kohut Wally Westman
Baroid Field Service Reps.	:	Tony Kowalski Innes Macleod

2. COST SUMMARY

2.1 Drilling Fluid Costs

	Drilling Fluid	Hole Size	MD From	MD To	Cost (AUS\$)
1.	SW/AQUAGEL Hi-vis Sweeps	36"	80.7 m	125.7 m	\$3,240.26
2.	SW/AQUAGEL Hi-vis Sweeps	12 ¹ / ₄ "	125.7 m	650 m	\$13,235.06
3.	NaCl/EZ-MUD/Polymer	8 ¹ / ₂ "	650 m	895 m	\$32,623.77
Mud Materials Used For Drilling				Total AUS\$	\$49,099.09

Mud Materials Not Used For Drilling:

Materials Used For Cementing	AUS\$	\$280.48
Materials Used For P & A	AUS\$	\$574.13
Waste NaCl Dumped	AUS\$	\$8,672.00
Total Materials	AUS\$	\$58,625.70

2.2 Engineering Costs

Service Representatives	From (date)	To (date)	Days
Tony Kowalski	08/10/99	19/10/99	12
Innes Macleod	11/10/99	17/10/99	7
Total Days			19
Service Cost @	AUS\$650 per day	Total (AUS\$)	\$12,350.00

Total Cost of Materials & Engineering **Total (AUS\$)** **\$70,975.70**

3.

PERFORMANCE SUMMARY

3.1 Comments

This well was drilled with no hole or mud related problems and no problems were encountered while logging. Two cores were successfully cut and casing was run without incident to programmed depth. Wireline logs were run right to bottom and the caliper log indicated good gauge hole. The total drilling fluid cost was within the programmed limit.

3.2 Performance Indicators

	Program	Actual	Achieved (± 10 %)
Interval 1 36" Hole			
80.7 m - 125.7 m (45 m drilled)			
• Volume Consumed, bbl	506	488	Yes
• Dilution Rate, bbl/m	0	0	Yes
• Consumption Rate, bbl/m	10.12	10.84	Yes
• Mud Cost/bbl, AUS\$	\$7.06	\$6.64	Yes
• Mud Cost/m, AUS\$	\$84.17	\$72.01	Yes
• Interval Mud Cost, AUS\$	\$4,208	\$3,240	Yes
Interval 2 12¹/₄" Hole			
125.7 m - 650 m (524.3 m drilled)			
• Volume Consumed, bbl	2,373	1,496	Yes
• Dilution Rate, bbl/m	0	0	Yes
• Consumption Rate, bbl/m	5.56	2.85	Yes
• Mud Cost/bbl, AUS\$	\$7.06	\$8.85	No
• Mud Cost/m, AUS\$	\$32.21	\$25.24	Yes
• Interval Mud Cost, AUS\$	\$16,751	\$13,235	Yes
Interval 3 8¹/₂" Hole			
650 m - 895 m (245 m drilled)			
• Volume Consumed, bbl	819	1,088	No
• Dilution Rate, bbl/m	0.8	1.24	No
• Consumption Rate, bbl/m	2.98	4.44	No
• Mud Cost/bbl, AUS\$	\$34.06	\$29.99	Yes
• Mud Cost/m, AUS\$	\$101.43	\$133.16	No
• Interval Mud Cost, AUS\$	\$27,893	\$32,624	No
Total Drilling Fluid Cost, AUS\$	\$48,853	\$49,099	Yes

Explanation of Non-Conformance

- Interval 2. The mud cost per barrel is higher than programmed due to the extra usage of AQUAGEL in order to utilise remaining bulk stocks, as per the Cultus representatives' instructions.
- Interval 3. Additional mud had to be mixed to maintain a safe circulating volume in the active pit in case of anticipated downhole losses. This resulted in higher than programmed mud volumes and costs. Note that the cost/bbl was well within the programmed limit.
- For logistical reasons at the conclusion of the well, 20 metric tonnes (5 x 4 mt bulk bins) of NaCl was dumped overboard at the request of the operator. The cost was charged as non-drilling materials.

4. INTERVAL - 1

4.1 SUMMARY

36" Hole From 80.7 m To 125.7 m In 1 Day

Drilling Fluid Seawater / Hi-Vis AQUAGEL Sweeps

Formations Gippsland Limestone

Properties	Programmed		Actual (Typical)		Conformance
	Min	Max	Min	Max	
Density, ppg				8.6	Yes
Funnel Viscosity, sec/qt	100		109	109	Yes

Explanation of Non-Conformance

- All mud properties conformed to programmed specifications.

Maintenance

- The hi-vis mud for sweeps was built with pre-hydrated AQUAGEL at 35 ppb diluted with seawater to 25 ppb. Caustic soda and lime were added to flocculate the Gel to produce the programmed funnel viscosity.
- The mud used for displacing the hole prior to running casing was built at 35 ppb pre-hydrated AQUAGEL. No lime was added to this mud.

4.2 EVALUATION

Comments

- This interval was drilled quickly and successfully with no hole or mud related problems. The 30" casing was run to bottom.

Problems, Causes, Remedial Action Taken or Recommended

Hole Conditions

- 1) Problem None
Cause
Action

Drilling Fluid

- 1) Problem None
Cause
Action

Solids Control and Mud Mixing Equipment

- 1) Problem None
Cause
Action

4.3 RECOMMENDATIONS FOR IMPROVEMENT

Hole Conditions

- No recommendations.

Drilling Fluid

- No recommendations.

Solids Control and Mud Mixing Equipment.

- No recommendations.

5. INTERVAL - 2

5.1 SUMMARY

12¹/₄" Hole From 125.7 m To 650 m In 1 Days

Drilling Fluid Seawater / Hi-Vis AQUAGEL Sweeps

Formations Gippsland Limestone

Properties	Programmed		Actual (Typical)		Conformance
	Min	Max	Min	Max	
Density, ppg			8.7	8.7	Yes
Funnel Viscosity, sec/qt	100		114	171	Yes

Explanation of Non-Conformance

- All mud properties conformed to programmed specifications.

Maintenance

- The hi-vis mud for sweeps was built with pre-hydrated AQUAGEL at 35 ppb and was diluted to 25 ppb with seawater. Caustic soda and lime were added to flocculate the Gel to produce the programmed funnel viscosity.
- The mud used (1,100 bbls) for displacing the hole prior to running casing was built at 35 ppb pre-hydrated AQUAGEL. No lime was added to this mud.

5.2 EVALUATION

Comments

- This interval was drilled quickly and successfully with no hole or mud related problems. The 9⁵/₈" casing was run to programmed depth without problem.

Problems, Causes, Remedial Action Taken or Recommended**Hole Conditions**

- 1) Problem None
Cause
Action

Drilling Fluid

- 1) Problem None
Cause
Action

Solids Control and Mud Mixing Equipment

- 1) Problem None
Cause
Action

5.3 RECOMMENDATIONS FOR IMPROVEMENT

Hole Conditions

- No recommendations.

Drilling Fluid

- No recommendations.

Solids Control and Mud Mixing Equipment.

- No recommendations.

6.

INTERVAL - 3

6.1 SUMMARY

12¹/₂" Hole From 650 m To 895 m In 3 Days

Drilling Fluid NaCl/EZ MUD/Polymer

Formations Lakes Entrance / Gumard / Latrobe / Strzelecki

Properties	Programmed		Actual (Typical)		Conformance
	Min	Max	Min	Max	
Mud Weight, ppg	10.0	10.5	10.1	10.1	Yes
6 rpm, lb/100 ft ²	8	10	6	8	No
API Filtrate		6	3.6	4.5	Yes
HPHT @ 250 F, ml		15	14.8	22.6	No
NaCl Content, %	6	8	6.9	8.0	Yes
pH	8.5	9.5	8.7	9.6	No
Excess PHPA, ppb	1		0.7	1.3	No
LGS, % v/v		8	0.3	3.3	Yes
Nitrate Content, mg/l	500		400	480	No

Explanation of Non-Conformance

- Low 6 rpm reading was that of newly mixed mud which at the time only contained 0.38 ppb of EZ-MUD.
- Due to shallowness of well and economic considerations, the operator's representatives gave instructions to concentrate on the API fluid loss rather than the HPHT fluid loss.
- Elevated pH occurred shortly after displacement following drilling out the 9⁵/₈" casing with seawater and was the result of residual cement traces.
- PHPA concentration was increased slightly based on condition of cuttings and increasing MBT.
- The programmed addition (0.4 ppb) of sodium nitrate only achieved a reading of approximately 400 mg/l nitrates and due to the limited quantity of product onboard and the additional mud volume required it was decided to try and maintain the nitrates at a constant reduced level.

Maintenance

- The drilling fluid was initially formulated with 8% NaCl, 2 ppb DEXTRID, 1 ppb of PAC-R, 0.8 ppb of XCD-POLYMER and 0.3 ppb of EZ-MUD DP. The initial mud weight was 10.1 ppg.
- The 9⁵/₈" casing shoe and three metres of new hole were drilled with seawater and the hole displaced to mud. A leak off test was then performed to 15.1 ppg EMW.
- Shortly after drilling began, 0.7 ppb EZ MUD was added to the active system and a constant mud formulation was maintained to provide full inhibition and cuttings integrity.
- Sodium nitrate was added as required after displacing the hole to mud, to maintain the nitrate content at 500 mg/l although the actual average concentration was approximately 400 mg/l.
- Regular additions of caustic soda were made to maintain pH levels.
- Occasional additional XCD-Polymer treatments were required to maintain a minimum 6 rpm reading of 8.
- An additional 189 bbls of mud was mixed prior to drilling the Latrobe formation in case of downhole losses, as per the Cultus representatives' instructions.

Solids Control Equipment

- The three Thule VSM 100 shale shakers were dressed with a combination of 52 and 120 mesh screens for the displacement of PHPA mud into the hole to avoid excessive losses of unsheared mud.
- The 3 Brandt scalper shakers had screens only on the top decks. These were 20, 10 and 20 mesh.
- When the PHPA concentration of the new NaCl/EZ-MUD/Polymer fluid was increased from 0.38 to 0.53 ppb there were considerable whole mud losses (approx. 45 bbls) over the shakers, particularly the scalpings, and also over the scalper shaker beds when bypassing.
- The sandtraps were not utilised during this interval to minimise mud usage.

5.2 EVALUATION**Comments**

- This interval was drilled successfully and problem free. The PHPA mud system performed very efficiently.

Problems, Causes, Remedial Action Taken or Recommended**Hole Conditions**

- | | |
|------------|--------------|
| 1) Problem | No problems. |
| Cause | |
| Action | |

Drilling Fluid

- | | |
|------------|--------------|
| 1) Problem | No problems. |
| Cause | |
| Action | |

Solids Control and Mud Mixing Equipment

- | | |
|------------|--|
| 1) Problem | Mud losses over front of Brandt scalper shaker beds. |
| Cause | Increasing PHPA content of recently displaced mud from 0.38 to 0.53 ppb. |
| Action | Reduced pump rate and temporarily halted PHPA addition. |

6.3 RECOMMENDATIONS FOR IMPROVEMENT**Hole Conditions**

- None.

Drilling Fluid

- None.

Solids Control and Mud Mixing Equipment.

- Install baffle in front of bypass valve under Brandt scalper shakers to divert mud sideways to prevent fluid overflowing the front of shaker beds when bypassing is excessive.

APPENDIX A - DEVIATION DATA

Depth (m)	Inclination (deg)
252	0.5
397	0.5
513	0.5
597	0.5
650	0.25

APPENDIX B - CALIPER DATA

Depth (m)	Caliper (ins.)
660	8.2
670	8.4
680	8.2
690	8.5
700	8.3
710	8.4
720	8.4
730	8.6
740	9.1
750	8.0
760	8.1
770	8.3
780	8.2
790	8.5
800	8.3
810	8.4
820	8.6
830	8.5
840	9.9
850	9.6
860	8.4
870	No caliper below this depth.
880	
890	
895	TD

908058 163

GRAPHS

DRILLING FLUID PERFORMANCE

Operator : Cultus Petroleum N.L.
Well : Baleen-2



Drilling Progress

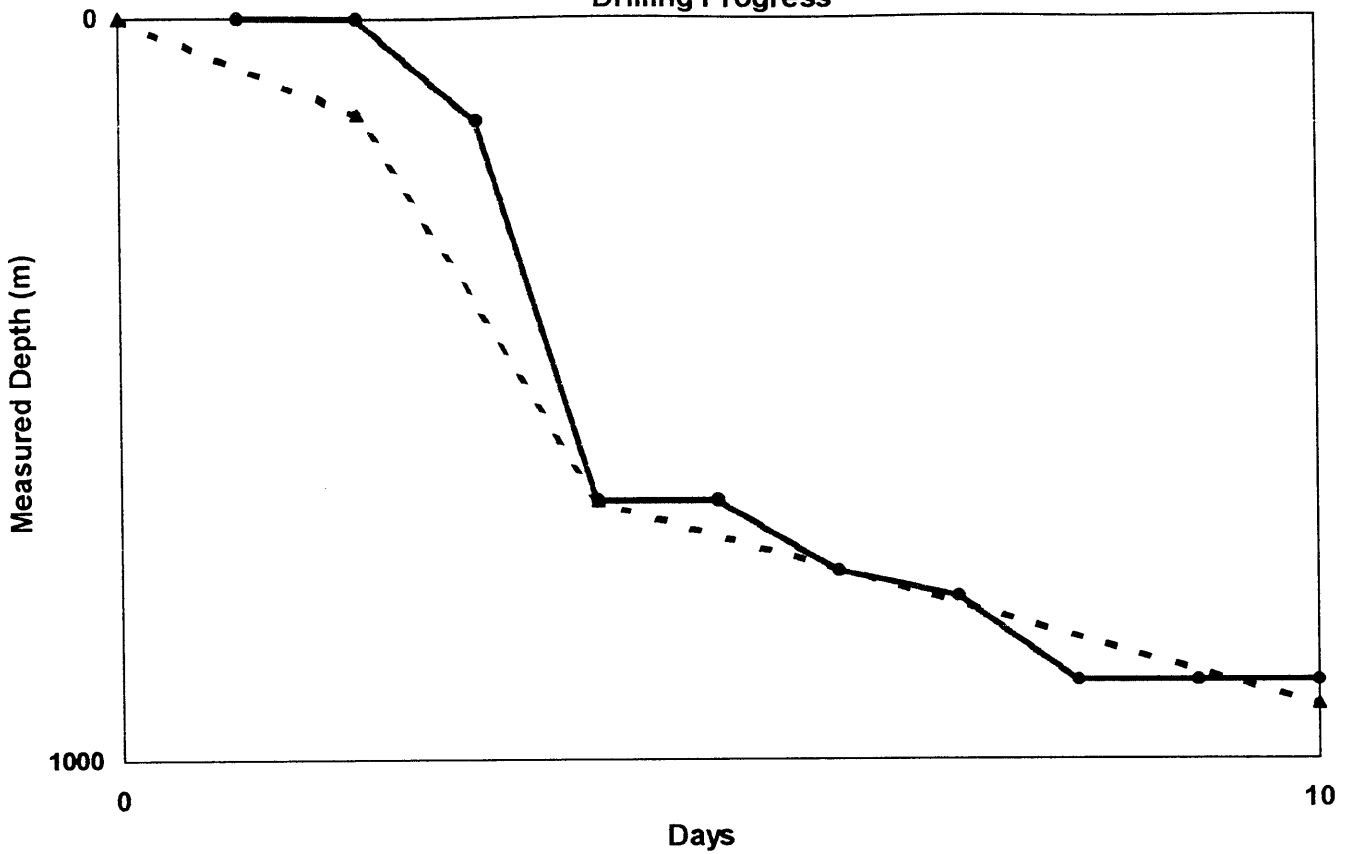

Fluid Cost

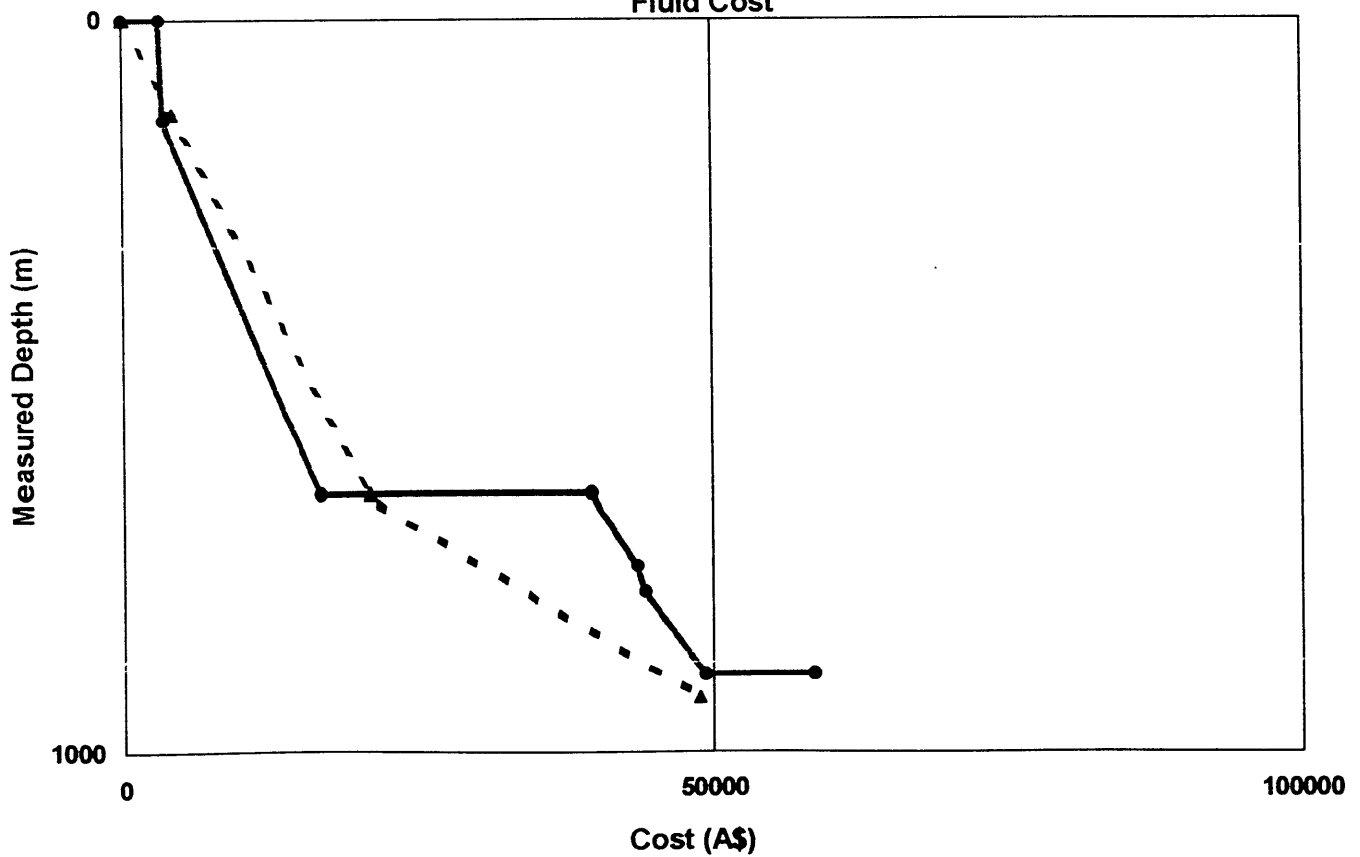

DRILLING FLUID PROPERTIES (Page - 1)

Operator : Cultus Petroleum N.L.
Well : Baleen-2

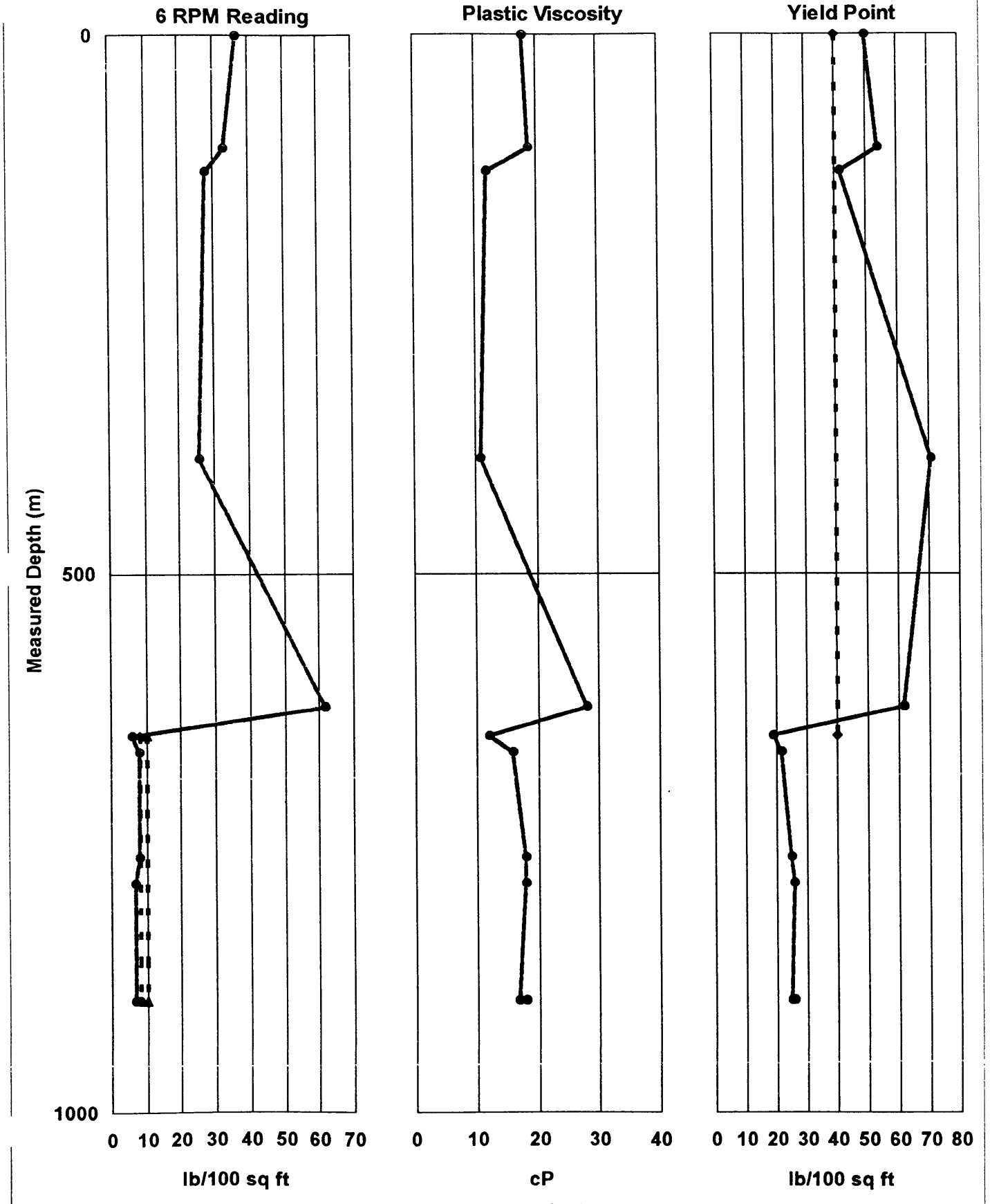

Baroid Australia Pty Ltd

DRILLING FLUID PROPERTIES (Page - 2)

Operator : Cultus Petroleum N.L.
Well : Baleen-2

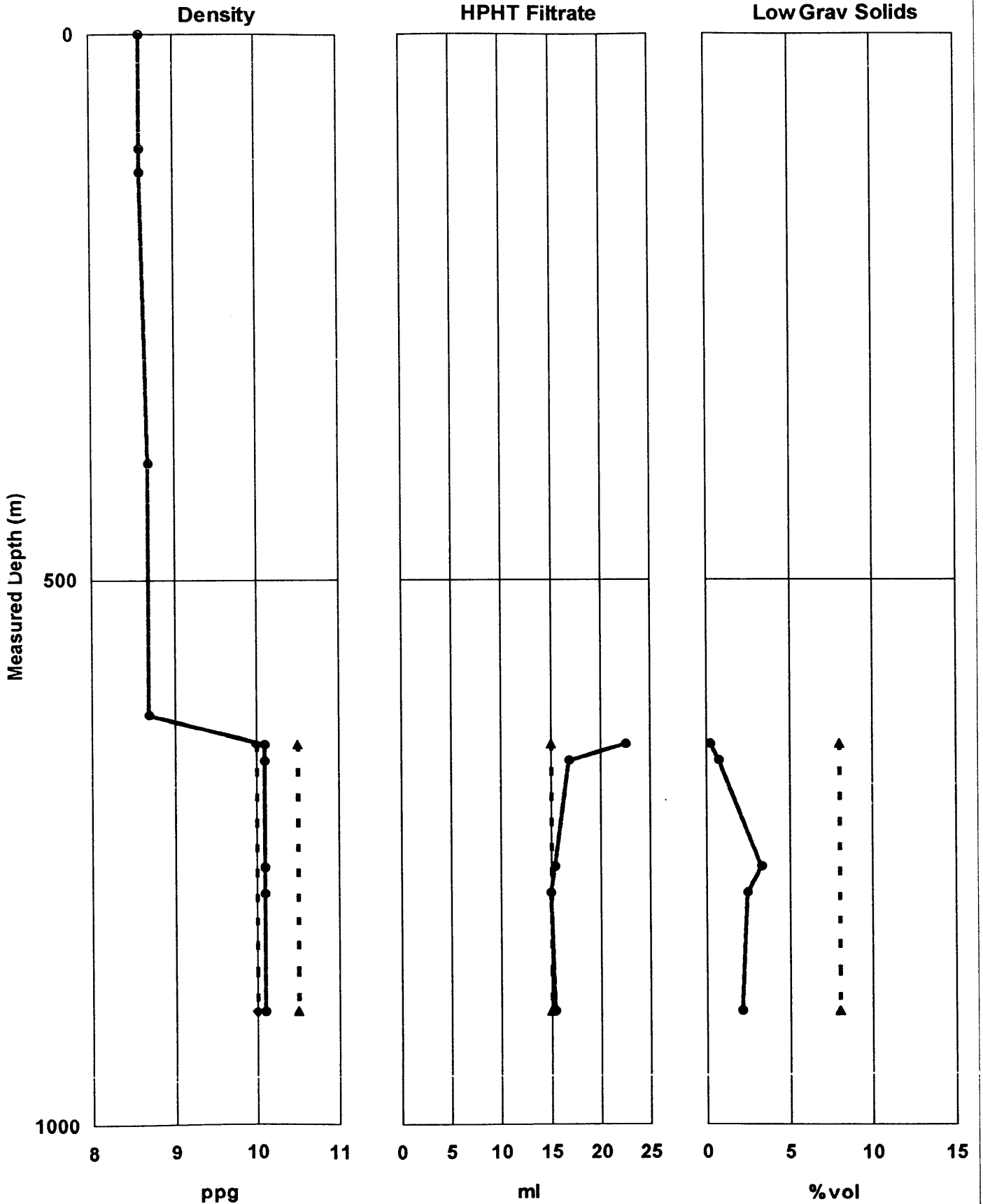

Baroid Australia Pty Ltd

908058 167

POST WELL AUDIT



Postwell Audit

Cultus Petroleum N.L.

Baleen-2

Drilling Contractor	Sedco Forex
Rig	702
Prepared by	HAYDEN BUTLER
Date	03/11/99
Internal Well Number	M0300356

Company: Cultus Petroleum N.L.
Well Name: Baleen-2
Contractor: Sedco Forex
Rig: 702

Country: AUSTRALIA
Geo Area: BASS STRAIT
Field: VIC/RL5
Region: Victoria



Contents

- Well summary
- Total material consumption
- Interval summary
- Interval material consumption
- Interval mud consumption
- Daily mud volume record
- Mud program exceptions report
- Mud property recap
- Daily operations log
- Bit and hydraulic record

Company: Cultus Petroleum N.L.
 Well Name: Baleen-2
 Contractor: Sedco Forex
 Rig: 702

Country: AUSTRALIA
 Geo Area: BASS STRAIT
 Field: VIC/RL5
 Region: Victoria



Well Summary

Well data

Spud date	:	11/10/99
TD date	:	16/10/99
Days on well	:	8
Drilling days	:	4
Water depth (RKB to seabed)	:	55 (81) meters
Total measured depth	:	895 meters
True vertical depth	:	895 meters
Distance Drilled	:	814 meters
Maximum deviation	:	0.75°
BHT	:	48 Deg C
Total mud cost	:	\$A 49,099.09
Mud cost per meters	:	\$A 60.29
Total cost	:	\$A 58,625.70
Baroid Engineers	:	TONY KOWALSKI INNES MACLEOD

Casing Program	Casing size in.	Shoe depth meters
	30	126
	9 5/8	646

Mud type	Interval meters	Hole size in.	Mud cost, \$A
Gel/Seawater	81 To 126	36	3,240.26
Gel/Seawater	126 To 650	12.25	13,235.06
EZ-MUD	650 To 895	8.5	32,623.77

Company: Cultus Petroleum N.L.
 Well Name: Baleen-2
 Contractor: Sedco Forex
 Rig: 702

Country: AUSTRALIA
 Geo Area: BASS STRAIT
 Field: VIC/RL5
 Region: Victoria



Total Material Consumption

Material	Unit size	Quantity	Total cost (\$A)
AQUAGEL	100 LB. BAG	602	15,543.64
barite	100 LB. BULK	747.000	11,122.83
caustic soda	25 KG. PAIL	21	1,097.04
DEXTRID LT	25 KG. BAG	50	3,209.50
EZ MUD DP	50 LB. SACK	17	2,375.92
lime	20 KG. BAG	16	200.32
PAC-R	25 KG. BAG	18	3,229.20
soda ash	25 KG. BAG	6	107.04
Sodium Chloride	1000 KG. BULK	9.283	4,025.11
sodium nitrate	25 KG. BAG	8	386.00
XCD Polymer	25 KG. BAG	17	7,802.49
Miscellaneous Items			
Cementing			280.48
Plug & Abandon			574.13
Waste Nacl			8,672.00

Total mud cost \$A 49,099.09

Total miscellaneous cost \$A 9,526.61

Total cost \$A 58,625.70

Programmed mud cost \$A 48,852.93

Variance \$A 246.16

Company: Cultus Petroleum N.L.
 Well Name: Baleen-2
 Contractor: Sedco Forex
 Rig: 702

Country: AUSTRALIA
 Geo Area: BASS STRAIT
 Field: VIC/RL5
 Region: Victoria



Interval Summary

Interval #	01
Bit Size	36 in.
Mud type(s)	Gel/Seawater
Top of interval	80.7 meters
Bottom of interval	125.7 meters
Maximum density	8.60 ppg
Interval start date	09/10/99
Interval end date	11/10/99
Interval days	3
Drilling days	1
Interval TD date	11/10/99
Rotating hours	4.25
Average penetration rate	10.6 meters
Bottomhole static temperature	30° Deg C
Maximum flowline temperature	0° Deg C
Casing size	30 in.
Major lithology	Sand / Shell
Maximum deviation	0.75°
Interval mud cost	\$A 3,240.26
Mud cost per (bbl)	\$A 6.64
Mud cost per meters	\$A 72.00
Total Interval Cost	\$A 3,485.68

Company: Cultus Petroleum N.L.
Well Name: Baleen-2
Contractor: Sedco Forex
Rig: 702

Country: AUSTRALIA
Geo Area: BASS STRAIT
Field: VIC/RL5
Region: Victoria

908058 173



Interval Summary

Interval #	02
Bit Size	12.25 in.
Mud type(s)	Gel/Seawater
Top of interval	125.7 meters
Bottom of interval	650.0 meters
Maximum density	8.70 ppg
Interval start date	12/10/99
Interval end date	12/10/99
Interval days	1
Drilling days	1
Interval TD date	12/10/99
Rotating hours	11.50
Average penetration rate	45.6 meters
Bottomhole static temperature	40° Deg C
Maximum flowline temperature	0° Deg C
Casing size	9 5/8" in.
Major lithology	Limestone
Maximum deviation	0.25°
Interval mud cost	\$A 13,235.06
Mud cost per (bbl)	\$A 8.85
Mud cost per meters	\$A 25.24
Total Interval Cost	\$A 13,235.06

Company: Cultus Petroleum N.L.
 Well Name: Baleen-2
 Contractor: Sedco Forex
 Rig: 702

Country: AUSTRALIA
 Geo Area: BASS STRAIT
 Field: VIC/RL5
 Region: Victoria



Interval Summary

Interval #	03
Bit Size	8.5 in.
Mud type(s)	EZ-MUD
Top of interval	650.0 meters
Bottom of interval	895.0 meters
Maximum density	10.10 ppg
Interval start date	13/10/99
Interval end date	18/10/99
Interval days	6
Drilling days	2
Interval TD date	16/10/99
Rotating hours	17.25
Average penetration rate	14.2 meters
Bottomhole static temperature	48° Deg C
Maximum flowline temperature	35° Deg C
Casing size	9 5/8 in.
Major lithology	Claystone, Sandstone
Maximum deviation	0.25°
Interval mud cost	\$A 32,623.77
Mud cost per (bbl)	\$A 29.99
Mud cost per meters	\$A 133.15
Total Interval Cost	\$A 41,904.96

Company: Cultus Petroleum N.L.
 Well Name: Baleen-2
 Contractor: Sedco Forex
 Rig: 702

Country: AUSTRALIA
 Geo Area: BASS STRAIT
 Field: VIC/RL5
 Region: Victoria



Interval Material Consumption

Interval #01 36 in. Hole Section

Top of Interval 81 meters
 Bottom of Interval 126 meters

Material	Unit size	Quantity	Total cost (\$A)
AQUAGEL	100 LB. BAG	117	3,020.94
caustic soda	25 KG. PAIL	3	156.72
lime	20 KG. BAG	5	62.60
Miscellaneous Items			
Cementing			245.42

Interval mud cost \$A 3,240.26

Interval miscellaneous cost \$A 245.42

Total interval cost \$A 3,485.68

Programmed mud cost \$A 4,208.26

Variance \$A -968.00

Company: Cultus Petroleum N.L.
 Well Name: Baleen-2
 Contractor: Sedco Forex
 Rig: 702

Country: AUSTRALIA
 Geo Area: BASS STRAIT
 Field: VIC/RL5
 Region: Victoria



Interval Material Consumption

Interval #02 12.25 in. Hole Section

Top of Interval 126 meters
 Bottom of Interval 650 meters

Material	Unit size	Quantity	Total cost (\$A)
AQUAGEL	100 LB. BAG	485	12,522.70
caustic soda	25 KG. PAIL	11	574.64
lime	20 KG. BAG	11	137.72

Interval mud cost \$A 13,235.06

Programmed mud cost \$A 16,751.31

Variance \$A -3,516.25

Company: Cultus Petroleum N.L.
 Well Name: Baleen-2
 Contractor: Sedco Forex
 Rig: 702

Country: AUSTRALIA
 Geo Area: BASS STRAIT
 Field: VIC/RL5
 Region: Victoria



Interval Material Consumption

Interval #03 8.5 in. Hole Section

Top of Interval 650 meters
 Bottom of Interval 895 meters

Material	Unit size	Quantity	Total cost (\$A)
barite	100 LB. BULK	747.000	11,122.83
caustic soda	25 KG. PAIL	7	365.68
DEXTRID LT	25 KG. BAG	50	3,209.50
EZ MUD DP	50 LB. SACK	17	2,375.92
PAC-R	25 KG. BAG	18	3,229.20
soda ash	25 KG. BAG	6	107.04
Sodium Chloride	1000 KG. BULK	9.283	4,025.11
sodium nitrate	25 KG. BAG	8	386.00
XCD Polymer	25 KG. BAG	17	7,802.49
Miscellaneous Items			
Cementing			35.06
Plug & abandon			574.13
Waste nacl			8,672.00

Interval mud cost \$A 32,623.77

Interval miscellaneous cost \$A 9,281.19

Total interval cost \$A 41,904.96

Programmed mud cost \$A 27,893.36

Variance \$A 4,730.41

Company: Cultus Petroleum N.L.
 Well Name: Baleen-2
 Contractor: Sedco Forex
 Rig: 702

County: AUSTRALIA
 Geo Area: BASS STRAIT
 Field: VIC/RL5
 Region: Victoria



Interval Mud Consumption

Interval #01

Hole size	36 in.	
Interval length	45.1	meters
Mud type(s)	Gel/Seawater	
Mud lost (downhole)	488.0	bbl
Mud lost (solids control)	0.0	bbl
Mud lost (surface)	0.0	bbl
Mud lost (evaporation)	0.0	bbl
Mud lost (other)	0.0	bbl
Mud dumped	0.0	bbl
Mud returned	0.0	bbl
Total mud lost	488.0	bbl
Mud consumption rate	10.818	bbl/meters
Surface loss rate	0.000	bbl/meters

Company: Cultus Petroleum N.L.
Well Name: Baleen-2
Contractor: Sedco Forex
Rig: 702

County: AUSTRALIA
Geo Area: BASS STRAIT
Field: VIC/RL5
Region: Victoria

908058 179



Interval Mud Consumption

Interval #02

Hole size	12.25 in.	
Interval length	524.3 meters	
Mud type(s)	Gel/Seawater	
Mud lost (downhole)	1,017.0	bbl
Mud lost (solids control)	0.0	bbl
Mud lost (surface)	0.0	bbl
Mud lost (evaporation)	0.0	bbl
Mud lost (other)	0.0	bbl
Mud dumped	86.0	bbl
Mud returned	0.0	bbl
Total mud lost	1,103.0	bbl
Mud consumption rate	2.104	bbl/meters
Surface loss rate	0.164	bbl/meters

Company: Cultus Petroleum N.L.
 Well Name: Baleen-2
 Contractor: Sedco Forex
 Rig: 702

County: AUSTRALIA
 Geo Area: BASS STRAIT
 Field: VIC/RL5
 Region: Victoria



Interval Mud Consumption

Interval #03

Hole size	8.5 in.	
Interval length	245.1	meters
Mud type(s)	EZ-MUD	
Mud lost (downhole)	73.0	bbl
Mud lost (solids control)	90.0	bbl
Mud lost (surface)	45.0	bbl
Mud lost (evaporation)	0.0	bbl
Mud lost (other)	284.0	bbl
Mud dumped	111.0	bbl
Mud returned	0.0	bbl
Total mud lost	603.0	bbl
Mud consumption rate	2.461	bbl/meters
Surface loss rate	2.163	bbl/meters



Country: AUSTRALIA
 Geo Area: BASS STRAIT
 Field: VIC/RL5
 Region: Victoria

Company: Cultus Petroleum N.L.
 Well Name: Baleen-2
 Contractor: Sedco Forex
 Rig: 702

Daily Mud Volume Record

MUD TYPE: Gel/Seawater

HOLE SIZE: 36 in.

DATE	INITIAL VOLUME bbl	MUD RECEIVED bbl	OIL ADDED bbl	WATER ADDED bbl	BARITE ADDED bbl	CHEMICALS ADDED bbl	CUMULATIVE TOTAL bbl	MUD LOST SURFACE bbl	MUD LOST DOWNHOLE bbl	TOTAL DAILY LOSSES bbl	CUMULATIVE LOSSES bbl	MUD RETURNED bbl	FINAL VOLUME bbl	HOLE VOLUME bbl	ACTIVE PITS bbl	RESERVE PITS bbl
09/10/99	0	0	0	0	0	0	0	0	0	0	0	0	0	0	0	0
10/10/99	0	0	0	475	0	13	488	0	0	0	0	0	488	0	0	488
11/10/99	488	0	0	0	0	0	488	0	488	488	488	488	0	106	106	0



Company: Cultus Petroleum N.L. Country: AUSTRALIA
 Well Name: Baleen-2 Geo Area: BASS STRAIT
 Contractor: Sedco Forex Field: VIC/RL5
 Rig: 702 Region: Victoria

Daily Mud Volume Record

HOLE SIZE: 12.25 in.

MUD TYPE: Gel/Seawater

DATE	INITIAL VOLUME bbl	MUD RECEIVED bbl	OIL ADDED bbl	WATER ADDED bbl	BARITE ADDED bbl	CHEMICALS ADDED bbl	DAILY TOTAL bbl	CUMULATIVE TOTAL bbl	MUD LOST SURFACE bbl	MUD LOST DOWNHOLE bbl	TOTAL DAILY LOSSES bbl	TOTAL DAILY LOSSES bbl	CUMULATIVE LOSSES bbl	MUD RETURNED bbl	FINAL VOLUME bbl	HOLE VOLUME bbl	ACTIVE PITS bbl	RESERVE PITS bbl
12/10/99	0	0	0	1,439	0	57	1,496	1,496	86	1,017	1,103	1,103	1,103	0	393	393	363	393



Country: AUSTRALIA
 Geo Area: BASS STRAIT
 Field: VIC/RL5
 Region: Victoria

Company: Cultus Petroleum N.L.
 Well Name: Baleen-2
 Contractor: Sedco Forex
 Rig: 702

Daily Mud Volume Record

HOLE SIZE: 8.5 in.

MUD TYPE: EZ-MUD

DATE	INITIAL VOLUME bbl	MUD RECEIVED bbl	OIL ADDED bbl	WATER ADDED bbl	BARITE ADDED bbl	CHEMICALS ADDED bbl	DAILY TOTAL bbl	CUMULATIVE TOTAL bbl	MUD LOST SURFACE bbl	MUD LOST DOWNHOLE bbl	TOTAL DAILY LOSSES bbl	CUMULATIVE LOSSES bbl	MUD RETURNED bbl	FINAL VOLUME bbl	HOLE VOLUME bbl	ACTIVE PITS bbl	RESERVE PITS bbl
13/10/99	393	0	0	805	41	13	869	869	0	51	51	51	0	1,201	228	228	1,201
14/10/99	1,201	0	0	38	3	1	40	899	142	0	142	193	0	1,096	220	484	396
16/10/99	1,096	0	0	0	0	0	0	899	12	0	12	205	0	1,087	256	447	382
16/10/99	1,087	0	0	174	7	8	189	1,068	34	15	49	254	0	1,227	284	601	342
17/10/99	1,227	0	0	0	0	0	0	1,068	58	7	65	319	0	1,182	284	594	284
18/10/99	1,182	0	0	0	0	0	0	1,068	284	0	284	603	0	878	284	284	878



Country: AUSTRALIA
 Geo Area: BASS STRAIT
 Field: VIC/RL5
 Region: Victoria

Company: Cullus Petroleum N.L.
 Well Name: Baleen-2
 Contractor: Sedco Forex
 Rig: 702

Mud Program Exceptions Report

DATE	TIME	DEPTH meters	PROPERTY	UNITS	EXCEPTION	PROGRAM MINIMUM	PROGRAM MAXIMUM	ACTUAL	PROBLEM
10/14/99	18:30	714	H. TEMP-H.PRESSURE FILTER.	ml/30 min	HIGH		15.0	16.0	
	13:00	666	H. TEMP-H.PRESSURE FILTER.	ml/30 min	HIGH		15.0	16.8	
10/15/99	08:00	763	H. TEMP-H.PRESSURE FILTER.	ml/30 min	HIGH		15.0	15.4	
10/16/99	07:45	787	6 rpm		LOW	8.0	10.0	7.0	
10/17/99	10:00	895	H. TEMP-H.PRESSURE FILTER.	ml/30 min	HIGH		15.0	15.4	
		895	6 rpm		LOW	8.0	10.0	7.0	



Company: **Cultus Petroleum N.L.**
 Well Name: **Baleen-2**
 Contractor: **Sedco Forex**
 702

Country: **AUSTRALIA**
 Geo Area: **BASS STRAIT**
 Field: **VIC/RL5**
 Region: **Victoria**

Mud Property Recap: Water-Based Mud

DATE	DEPTH meters	FIL TEMP Deg C	DENSITY ppg	FUN VIS sec/qt	RHEOLOGY @ 120°F			pH	FILTRATION				Coke 32nd in Deg C	Temp Deg C	FILTRATE ANALYSIS				SAND % by vol	RETORT ANALYSIS				MBT me/ml mud	RHEOMETER DIAL READINGS											
					PV cP	VP lb/100 ft.2	Y.P lBELS		API ml/30 ml	HTHP ml/30 min	Fm ml	Pf ml			Mf ml	Cl mg/L	Total Hardness mg/L	Corr Solids % by vol		LGS % by vol	Oil % by vol	Water % by vol	600/300		200/100	6/3										
09/0/99			8.3	28		1.0						2/0	121												/	/	/									
10/0/99			8.8	109		18.0	50.0	32.0/48.0	9.70																											
11/0/99	126		8.6	118		19.0	54.0	32.0/44.0	10.20																											
12/0/99	650		8.7	114		11.0	71.0	27.0/35.0	10.60				121																							
13/0/99	850		10.1	47		12.0	19.0	4.0/6.0	9.80	4.5	22.80	1/2	121	0.25	0.03	0.08	0.08	51,000	220.0	Nil	5.10	0.25						92.00								
14/0/99	746	34	10.1	47		22.0	20.0	5.0/6.0	9.00	3.6	18.00	1/2	121	0.20	0.02	0.08	45,500	180.0	0.5	5.83	0.83						91.80	0.60	64	42	33	22	8	6		
15/0/99	760	27	10.1	61		22.0	25.0	5.0/6.0	8.70	3.6	14.80	1/2	121	0.20	0.01	0.06	44,000	180.0	0.5	7.05	3.64						90.50	1.20	68	47	40	27	8	5		
16/0/99	896	35	10.1	49		18.0	27.0	5.0/6.0	9.00	3.4	14.80	1/2	250	0.47	0.04	0.09	48,500	200.0	0.65	6.80	2.81						90.80	1.10	83	45	37	25	8	6		
17/0/99	896		10.1	50		17.0	25.0	5.0/7.0	9.00	3.6	15.40	1/2	250	0.38	0.03	0.07	48,500	190.0	0.50	6.18	2.10					81.20	1.00	59	42	34	24	7	6			
18/0/99	896		10.1	52		18.0	28.0	5.0/7.0	9.50	3.8		1/0		0.28	0.40	1.00	45,000	320.0									62	44	35	23	8	5				

Company: Cultus Petroleum N.L.
 Well Name: Baleen-2
 Contractor: Sedco Forex
 Rig: 702

Country: AUSTRALIA
 Geo Area: BASS STRAIT
 Field: VIC/RL5
 Region: Victoria



Daily Operations Log

DATE	DEPTH meters	OPERATION
09/10/99	0	
10/10/99	0	RUNNING ANCHORS Baroid engineer arrived on rig at 11:15 hrs on October 8, 1999. Rig under tow to Baleen-2 location. Arrived on location at noon on October 10. Running anchors at report time.
11/10/99	126	DRILLING Reran anchor and established position. Spudded Baleen-2 at 02:15 hrs on Oct 12 with a 26" bit and 36" hole opener drilling with seawater with returns to seabed. Pumped hi-vis sweeps as required, 50 bbls at TD at 125.7 m and displaced hole with 275 bbls (150% OH volume) prior to pulling out. Ran and cemented 30" casing at 125.7 m. WOC and made up 17 1/2" bit and BHA. RIH and drill out cement and shoe to 125.7m. POOH and lay out BHA. Make up 12 1/4" BHA and RIH. Drill from 125.7m to 137m.
12/10/99	650	RUN CASING Continued drilling 12 1/4" hole with seawater and hi-vis sweeps. Drilled to 650 m, circulated and made wiper trip. Pumped 50 bbl hi-vis sweep and then displaced hole with 150% OH volume of hi-vis gel mud. Pulled out of hole and rigged to run 9 5/8" casing. Running 9 5/8" casing.
13/10/99	650	TEST BOP Ran 9 5/8" casing and cemented at 646.4 m. Ran and tested BOP's and riser.
14/10/99	746	POOH Continued testing BOP'S. Made up 8 1/2" bit and BHA and ran in hole. Tagged TOC at 596 m and drilled shoe track Pumped 50 bbl hi-vis gel sweep followed by 50 bbls of seawater and then displaced hole to salt polymer mud. Drilled 4 m new hole to 654 m and carried out LOT to an EMW of 15.1 ppg. Resumed drilling 8 1/2 " hole to 746m, circulating samples up to pick core point. POOH to core. Nitrates=400 mg/l
15/10/99	780	POOH WITH CORE #2 Finished pulling out of hole. Made up core barrel and ran back in hole. Circulated and dropped ball. Cut core #1 from 646-763 m. POOH and recovered core. RIH, circulated and dropped ball. Cut core #2 from 763-780 m. POOH with core #2.

Company: Cultus Petroleum N.L.
 Well Name: Baleen-2
 Contractor: Sedco Forex
 Rig: 702

Country: AUSTRALIA
 Geo Area: BASS STRAIT
 Field: VIC/RL5
 Region: Victoria



Daily Operations Log

DATE	DEPTH meters	OPERATION
16/10/99	895	WIRELINE LOGGING Pulled out of hole and recovered core #2. Ran back in hole with 8 1/2 " bit Reamed core hole from 646 m to bottom. Drilled to TD at 895 m. Circulated 2 times bottom up (shakers clean) and pulled out of hole. Rigged up Schlumberger and running wireline logs at report time.
17/10/99	895	WIRELINE LOGGING Continued wireline logging.
18/10/99	895	PLUG & ABANDON Continued wireline logging. Rigged down, picked up tubing and ran in Circulated bottoms up and set cement plug #1 from 890-790 m. Pulled to 760 m and circulated bottoms up-no cement to surface. Set cement plug #2 from 760-660 m and pulled to 550 m and circulated bottoms up -no cmt. Pulled out of hole and laid out tubulars. Ran in and tagged TOC #2 cmt plug at 580 m. Ran guage ring and set bridge plug at 180 m Disp riser to s/w. Cmt plug #3 175-125 m Reverse circ out cement and then convent.



Country: AUSTRALIA
 Geo Area: BASS STRAIT
 Field: VIC/RL5
 Region: Victoria

Company: Cultus Petroleum N.L.
 Well Name: Baleen-2
 Operator: Sedco Forex
 702

Bit and Hydraulic Record

DATE	BIT NO.	BIT SIZE in.	BIT MAKE	BIT TYPE	JETS or TFA	DEPTH OUT meters	DRILLED meters	HOURS RUN	CUM HOURS	WEIGHT ON BIT lb/1000	BIT RPM	PUMP OUTPUT gpm	ANN. VEL DP/DC m/min	PUMP PRESSURE psig	MUD WEIGHT ppg	BIT GRADING	MUD TYPE, LITHOLOGY, REMARKS
11/10/99	3	12.25	HYALOG	DSJ-C	18-18-18-1	650	524	12	17	10	125	1029	61/94	2050	9	1-1-CT-NO-	Sea water. Hi. Via Sweeps Opposed Limestone NICEZ MUD/Polymer Lanes Entrance
13/10/99	4	8.50	REED	MH13G	18-18-18	746	98	11	29	15	70	643	101/159	1525	10	2-3-WT-C-E	NICEZ MUD/Polymer Lanes Entrance
15/10/99	5	8.50	DBS	CD-73		763	17	2	31	15	100	193	31/48	550	10	1-2-CT-S-4	NICEZ MUD/Polymer Gravel
16/10/99	6	8.50	REED	HP-43	14-14-14	895	115	6	6	12	40	601	108/149	2300	10	1-1-NO-ALL	NICEZ MUD/Polymer Lettobe, Bitzweck
11/10/99	2RRR	17.50	SMITH	MSDSS HO	22-24-24-2	128		2	6		0	0/0			8	1-1-WT-A-E	Sea water. Cement
11/10/99	RR1	28.00	REED	DSJ-C	16-24-24-2	128	45	4	4	8	60	1004	0/8	800	9	1-1-NO-ALL	Sea water. Drilled out cement in 30' Bit
15/10/99	RR5	8.50	DBS	CD-73		780	17	2	38	12	40	193	31/48	550	10	1-2-WT-S-X	NICEZ MUD/Polymer Gravel

Sea water. Hi. Via Sweeps Opposed

Sea water. Cement

Sea water. Drilled out cement in 30' Bit

DAILY MUD REPORTS

Baroid Australia Pty Ltd
DRILLING MUD REPORT

REPORT NUMBER: 1

Date	Depth
09/10/99	0.0 m [MD]
Spud Date	Present Activity
11/10/99	

OPERATOR Cultus Petroleum N.L.	CONTRACTOR Sedco Forex	RIG NUMBER 702
REPORT FOR Ray Kahut / Wally Westman	REPORT FOR L. Macracken / R. Nagle	REGION Victoria
WELL NAME AND NUMBER Baleen-2	FIELD OR BLOCK VIC/RL5	GEOGRAPHIC AREA Bass Strait
		COUNTRY Austral

BIT DATA		DRILLING STRING			CASING		CIRCULATION DATA		
Size	in.	Pipe OD	ID	Len.			Pump Make/Model	Oilwell A1700FT	
Type		Pipe OD	ID	Len.	in.	m	Size	6 X 12	Eff. 97.00 V/st 0.102
No. Jets		Pipe OD	ID	Len.	Set	0	rpm	0	bbl/min 0.0
Jets 32nd inch		Collar OD	ID	Len.	Set	0	Pump Make/Model	Oilwell A1700FT	
		Collar OD	ID	Len.	Set	0	Size	6 X 12	Eff. 97.00 V/st 0.102
		in. OPEN HOLE			Set	0	rpm	0	bbl/min 0.0
Tot Moz Area	Size	Len.		Set	0		Pump Make/Model	Oilwell A1700FT	
TFA	Size	Len.		Set	0		Size	6 X 12	Eff. 97.00 V/st 0.102
	Size	Len.		Set	0		rpm	0	bbl/min 0.0
	Size	Len.		Set	0		Tot. Vol./min	0	gpm 0.0 bbl
	Size	Len.		Set	0		BU Time	0	TC Time 0

MUD PROPERTIES		Primary	2	3	Program	Essential
Source	Flowline				Targets	Program
Time	09:14				-Knoep	Properties
FL Temp	Deg F	32			P 2 3	
Depth	m	0.0				
Weight	ppg	8.3				
FV @ 60	Deg F sec/qt	28				
FV @ 120	Deg F cP	1				
YP	lbs/100 ft2	0				
Gels	lbs/100 ft2	0/0				
API Filt.	ml/30 min	0.0				
HTHP @ 150	Deg F ml/30 min	0.0				
Cake API/HTHP	32nd in	2/0				
Corr. Solids % by vol		0.0				
Oil/Water % by vol		0.0/0.0				
Sand % by vol						
NST		0.0				
pH STRIP		0.0				
Alk. Mud (Pa)		0.00				
Alk. Filtr. (PE/NE)		0.00/0.00				
Chlorides mg/l		0				
Hard. Ca mg/l		0				
Low Gravity Solids	ppb	0.00				

MUD TREATMENTS			

RIG ACTIVITY			

MATERIALS USED		SOLIDS EQUIPMENT			
NO INVENTORY USED ON THIS REPORT					
Device	Make	Sz/Scrn	HR		
Shkr #1	Brandt	20			
Shkr #2	Brandt	10			
Shkr #3	Brandt	20			
Shkr #4	Thule	120/52			
Shkr #5	Thule	120/52			
Shkr #6	Thule	52/52			
dSndr		3 x 12			
dSlc #1		16 x 4			

MUD MANAGEMENT		RHEOLOGY AND HYDRAULICS		FRACTURE GRADIENT TIME	
MUD VOLUME	bbl	MUD TYPE		Water Depth	54.8
Hole	Pits	SEAWATER/MI VIS SWEEPS	600 rpm	Calc. F. Grad	0.0
0	0	MUD CONSUMPTION	300 rpm	Leak Off Test	0.0
Active Volume		ADDITIONS	200 rpm	RCD	PPG
0		Oil	100 rpm	Cag. Shoe	0.0
Reserve	Total	Brine Water	6 rpm	TD	0.0
0		Drill Water	3 rpm	Max. Diff. Press	0
Low Grav. vol %	0.0	Sea Water	Pressure Units:		
ppb	0.00	Whole Mud	Press Drop. DP	peig	
High Grav. vol %	0.0	Barite	Press Drop. BIT	0	
ppb	0.00	Chemicals	Press Drop. ANN	0	
ASG	2.60	LOSSES	Actual Circ. Press	0	
Drill Cuttings	0	Dumped	AV, DP	ft/min	0
Dilution Rate	0.00	Lost	AV, DC	ft/min	0
Slide Control Eff	0.00	VOL GAIN/LOSS	AV, Riser	ft/min	0
BAROID REPRESENTATIVE	OFFICE/HOME	Cheltenham, Vic	TELEPHONE	03 9561 7555	DAILY COST
Tony Kowalski	WAREHOUSE	Barry Beach	TELEPHONE	03 5688 1445	CUMULATIVE COST
					\$A 0.00 \$A 0.00

NOTE: ALL COSTS ARE REPORTED IN AUSTRALIA'S DOLLAR
The recommendations made hereon shall not be construed as authorizing the infringement of any valid patent, and are made without assumption of any liability by BAROID DRILLING FLUIDS, INC. or its agents, and are statements of opinion only.

Baroid Australia Pty Ltd
DRILLING MUD REPORT
(Cost Modified)

REPORT NUMBER: 2

Date	10/10/99	Depth	0.0 m [MD]
Spud Date	11/10/99	Present Activity	RUNNING ANCHORS

OPERATOR Cultus Petroleum N.L.	CONTRACTOR Sedco Forex	RIG NUMBER 702
REPORT FOR Ray Kahut / Wally Westman	REPORT FOR L. Macracken / R. Nagle	REGION Victoria
WELL NAME AND NUMBER Baleen-2	FIELD OR BLOCK VIC/RL5	GEOGRAPHIC AREA Bass Strait
		COUNTRY Austral

BIT DATA		DRILLING STRING			CASING		CIRCULATION DATA		
Size 26 in.	Pipe OD	5	ID	3.000	Len.	111.1	Pump Make/Model	Oilwell A1700FT	
Type REED D&J-C	Pipe OD		ID		Len.		Size 6 X 12	Eff.	97.00
No. Jets	Pipe OD		ID		Len.		Set @	rpm	0
Jets 32nd inch	Collar OD	8.25	ID	2.875	Len.	29.6	Set @	Pump Make/Model	Oilwell A1700FT
16	24	24	Collar OD	9.5	ID	3.189	Len.	33.5	Set @
24			in. OPEN HOLE				Set @	rpm	0
Tot Max Area	Size		Len.		Set @		Pump Make/Model	Oilwell A1700FT	
TPA	Size		Len.		Set @		Size 6 X 12	Eff.	97.00
	Size		Len.		Set @		rpm	0	bbl/min
	Size		Len.		Set @		Tot. Vol./min	0	gpm
	Size		Len.		Set @		BU Time	0	TC Time

MUD PROPERTIES				MUD TREATMENTS			
Primary				2			
Source	Pits, Uocr			Program	Essential	A total of 1537 bbls of mud had been mixed as below as of 2400 hrs on October 10.	
Time	22:30			Targets	Program	Pit #1 - 314 bbls SW Gel (requires more Gel	
FL Temp	Deg F	32		**Excep	Properties	Pit #2 - 389 bbls Prehydrated FW Gel	
Depth	m	0.0		P	2	Pit #3 - 399 bbls SW diluted flocced Gel	
Weight	ppg	8.6				Pit #4 - 408 bbls 10.5 EZ-MUD/Polymer kill*	
FV @ 68 Deg F	sec/qt	109				* No Salt yet added to this mud.	
FV @ 66 Deg F	cp	18				Volume and cost of polymer mud and gel for 12 1/4" interval not considered.	
YP	lbs/100 ft ²	50					
Gels	lbs/100 ft ²	12/48					
API Filt.	ml/30 min	0.0					
HTHP @ 32 Deg F	ml/30 min	0.0					
Cake API/HTHP	32nd in	0/0					
Corr. Solids % by vol		0.0					
Oil/Water % by vol		0.0/0.0					
Sand % by vol							
NBT		0.0					
pH STRIP		9.7					
Alk. Mud (Pm)		0.00					
Alk. Filtr. (PF/ME)		0.00/0.00					
Chlorides mg/l		0					
Hard. Ca mg/l		0					
Low Gravity Solids ppb		0.00					

MATERIALS USED				SOLIDS-EQUIPMENT					
Product	Used	Cost	Product	Used	Cost	Device	Make	Sz/Scrn	HR
AQUAGEL - 100 LB. BAG	117	3020.94				Shkr #1	Brandt	20	
caustic soda - 25 KG. PAIL	3	156.72				Shkr #2	Brandt	10	
lime - 20 KG. BAG	5	62.60				Shkr #3	Brandt	20	
						Shkr #4	Thule	120/52	
						Shkr #5	Thule	120/52	
						Shkr #6	Thule	52/52	
						dSndr		3 x 12	
						dslt #1		16 x 4	

MUD MANAGEMENT			RHEOLOGY AND HYDRAULICS			FRACTURE GRADIENT TIME			
MUD VOLUME	bbbl	MUD TYPE				Water Depth	54.8	DRLG	0.00
Hole	Pits	SEAWATER/HI VIS SWEEPS	600 rpm	86		Calc. F. Grad	0.0	CIRC	0.00
0	0	MUD CONSUMPTION	300 rpm	68		Leak Off Test	0.0	TRIPS	0.00
Active Volume		ADDITIONS	200 rpm	60		ECD	ppg	SERV. RIG	0.00
0		Oil	100 rpm	52		Csg. Shoe	0.0	SURVEY	0.00
Reserve	Total	Brine Water	6 rpm	37		TD	0.0	FISHING	0.00
488	488	Drill Water	3 rpm	28		Max. Diff. Press	0	LOGGING	0.00
Low Grav, vol %	0.0	Sea Water	Pressure Units:	paig				RUN CSG	0.00
ppb	0.00	Whole Mud	0 Press Drop, DP	0				CORE	0.00
High Grav, vol %	0.0	Barite	0 Press Drop, BIT	0				BACK REAM	0.00
ppb	0.00	Chemicals	13 Press Drop, ANN	0				REAMING	0.00
ASG		LOSSES	Actual Circ. Press	0				TESTING	0.00
Drill Cuttings	0	Dumped	0 AV, DP	ft/min	0			OTHER	24.00
Dilution Rate	0.00	Lost	0 AV, DC	ft/min	0			AVERAGE ROP	0.00
Slids Control Eff	0.00	VOL GAIN/LOSS	488 AV, Riser	ft/min					

BAROID REPRESENTATIVE	OFFICE/HOME	Cheltenham, Vic	TELEPHONE	03 9581 7555	DAILY COST		CUMULATIVE COST	
Tony Kowalski	WAREHOUSE	Barry Beach	TELEPHONE	03 5688 1445	\$A	3240.26	\$A	3240.26

NOTE: ALL COSTS ARE REPORTED IN AUSTRALIA'S DOLLAR

The recommendations made hereon shall not be construed as authorizing the infringement of any valid patent, and are made without assumption of any liability by BAROID DRILLING FLUIDS, INC. or its agents, and are statements of opinion only.

Baroid Australia Pty Ltd
 DRILLING MUD REPORT
 (Cost Modified)

REPORT NUMBER: 3

Date	Depth
11/10/99	137.0 m [MD]
Spud Date	Present Activity
11/10/99	DRILLING

OPERATOR	CONTRACTOR	RIG NUMBER
Cultus Petroleum N.L.	Sedco Forex	702
REPORT FOR	REPORT FOR	REGION
Ray Kohut / Wally Westman	L. Macracken / R. Nagle	Victoria
WELL NAME AND NUMBER	FIELD OR BLOCK	GEOGRAPHIC AREA
Baleen-2	VIC/RL5	Bass Strait
		COUNTRY
		Austral

BIT DATA		DRILLING STRING				CASING			CIRCULATION DATA		
Size	12.25 in.	Pipe OD	ID	Len.					Pump Make/Model	Oilwell A1700FT	
Type	HYCALOG D840H	Pipe OD	5	ID 3.000	Len. 23.0	in.			Size 6 X 12	Eff. 97.00	v/st 0.102
No. Jets		Pipe OD		ID	Len.	30	Set @ 125.7	spm	82	bbl/min	8.4
Jets	32nd inch	Collar OD	8.25	ID 2.875	Len. 114.0		Set @	Pump Make/Model	Oilwell A1700FT		
18	18	18		Collar OD	ID	Len.	Set @	Size 6 X 12	Eff. 97.00	v/st 0.102	
				in. OPEN HOLE			Set @	spm	82	bbl/min	8.4
Tot Moz Area		Size	12.25	Len.	11.3		Set @	Pump Make/Model	Oilwell A170FT		
TFA		Size		Len.			Set @	Size 6 X 12	Eff. 97.00	v/st 0.102	
		Size		Len.			Set @	spm	81	bbl/min	8.3
		Size		Len.			Set @	Tot. Vol./min	1048	gpm	24.9
		Size		Len.			Set @	BU Time	4	TC Time	.0

MUD PROPERTIES				MUD TREATMENTS			
Primary				2			
Source	Pits, Uncr	Pits, Uncr		Program	Essential Program Properties		
Time	04:30	22:00		Targets	79.9 130.1		
FL Temp	Deg F	32	32	*-Excep			
Depth	m	104.0	125.7	P	2	3	
Weight	PPG	8.6	8.6				
FV @ 66 Deg F	sec/qt	118	103				
FV @ 66 Deg F	cp	19	12				
YP	lbe/100 ft ²	54	42				
Gels	lbe/100 ft ²	32/44	24/38				
API Filt.	ml/30 min	0.0	0.0				
HTHP @ 250 Deg F	ml/30 min	0.0	0.0				
Cake API/HTHP	32nd in	0/0	0/0				
Corr. Solids % by vol		0.0	0.0				
Oil/Water % by vol		0.0/0.0	0.0/0.0				
Sand % by vol							
MST		0.0	0.0				
pH STRIP		10.2	10.5				
Alk. Mud (Pm)		0.00	0.00				
Alk. Filtr. (PF/ME)		0.00/0.00	0.00/0.00				
Chlorides mg/l		0	0				
Hard. Ca mg/l		0	0				
Low Gravity Solids ppb		0.00	0.00				

Used a total of 488 bbls mud on 36" hole interval-213 bbls of SW diluted lime flocculated gel for sweeps and 275 bbls of undiluted gel for spotting prior to POOH. Prehydrated an additional 480 bbls of gel for 12 1/4" interval. 14 sacks calcium chloride used for cut job.

RIG ACTIVITY
 Reran anchor and established position. Spudded Baleen-2 at 02:15 hrs on Oct 12 with a 26" bit and 36" hole opener drilling with seawater with returns to seabed. Pumped hi-vis sweeps as required, 50 bbls at TD at 125.7 m and displaced hole with 275 bbls (150% OH volume) prior to pulling out. Ran and cemented 30" casing at 125.7 m. WOC and made up 17 1/2" bit and BHA. RIG and drill out cement and shoe to 125.7m. POOH and lay out BHA. Make up 12 1/4" BHA and RIG. Drill from 125.7m to 137m.

MATERIALS USED

NO INVENTORY USED ON THIS REPORT

SOLIDS EQUIPMENT

Device	Make	Sz/Scrr	HR
Shkr #1	Brandt	20	
Shkr #2	Brandt	10	
Shkr #3	Brandt	20	
Shkr #4	Thule	120/52	
Shkr #5	Thule	120/52	
Shkr #6	Thule	52/52	
dendr		3 x 12	
dslt #1		16 x 4	

MUD MANAGEMENT		RHEOLOGY AND HYDRAULICS				FRACTURE GRADIENT TIME					
MUD VOLUME	bbbl	MUD TYPE					Water Depth	54.8	DRIG	4.25	
Hole	Pits	SEAMATER/HI VIS SWEEPS	600	rpm	92	66	Calc. P. Grad	0.0	CIRC	1.25	
109	-109	MUD CONSUMPTION	300	rpm	73	54	Leak Off Test	0.0	TRIPS	8.00	
Active Volume		Oil	200	rpm	64	44	ECD	PPG	SERV. RIG	0.00	
0		Brine Water	0	100	rpm	54	38	Csg. Shoe	8.7	SURVEY	0.00
Reserve	Total	Drill Water	0	6	rpm	33	28	TD	8.8	FISHING	0.00
0		Sea Water	0	3	rpm	27	24	Max. Diff. Press	0	LOGGING	0.00
Low Grav, vol %	0.0	Whole Mud	Pressure Units: psig								
ppb	0.00	Barite	0	Press Drop. DP	697				DEVIATION INFO		
High Grav, vol %	0.0	Chemicals	0	Press Drop. BIT	559				MD	137.0	m
ppb	0.00	LOSSES	0	Press Drop. ANN	5				TVD	137.0	m
ASG		Dumped	0	Actual Circ. Press	1600				Angle	0.75	
Drill Cuttings	191	Loat	488	AV, DP	ft/min 0				Direction		
Dilution Rate	13.63	VOL GAIN/LOSS	-488	AV, DC	ft/min 313				Horiz. Displ	0.0	m
Slide Control Eff	0.00					AV, Riser ft/min					
BAROID REPRESENTATIVE		OFFICE/HOME	Cheltenham, Vic		TELEPHONE	03 9581 7555		DAILY COST	CUMULATIVE COST		
Tony Kowaleki / Innes Macleod		WAREHOUSE	Barry Beach		TELEPHONE	03 5688 1445		\$A	0.00	\$A	248.26

NOTE: ALL COSTS ARE REPORTED IN AUSTRALIA'S DOLLAR

The recommendations made hereon shall not be construed as authorizing the infringement of any valid patent, and are made without assumption of any liability by BAROID DRILLING FLUIDS, INC. or its agents, and are statements of opinion only.

Baroid Australia Pty Ltd
 DRILLING MUD REPORT
 (Cost Modified)

REPORT NUMBER: 4	
Date 12/10/99	Depth 650.0 m (MD)
Spud Date 11/10/99	Present Activity RUN CASING

OPERATOR Cultus Petroleum N.L.	CONTRACTOR Sedco Forex	RIG NUMBER 702
REPORT FOR Ray Kohut / Wally Westman	REPORT FOR L. Macracken / R. Nagle	REGION Victoria
WELL NAME AND NUMBER Baleen-2	FIELD OR BLOCK VIC/RL5	GEOGRAPHIC AREA Bass Strait
		COUNTRY Austral

BIT DATA		DRILLING STRING				CASING		CIRCULATION DATA			
Size	in.	Pipe OD	ID	Len.				Pump Make/Model	Oilwell A1700PT		
Type		Pipe OD	ID	Len.		in.	m	Size 6 X 12	Eff.	97.00	V/st 0.102
No. Jets		Pipe OD	ID	Len.		30	Set @ 125.7	spm 80	bbl/min	8.1	
Jets 32nd inch		Collar OD	ID	Len.			Set @	Pump Make/Model	Oilwell A1700PT		
		Collar OD	ID	Len.			Set @	Size 6 X 12	Eff.	97.00	V/st 0.102
		in. OPEN HOLE					Set @	spm 80	bbl/min	8.1	
Tot Noz Area		Size	12.25	Len.	524.3		Set @	Pump Make/Model	Oilwell A1700PT		
TPA		Size		Len.			Set @	Size 6 X 12	Eff.	97.00	V/st 0.102
		Size		Len.			Set @	spm 80	bbl/min	8.1	
		Size		Len.			Set @	Tot. Vol./min 1026 gpm 24.4 bbl			
		Size		Len.			Set @	BU Time 0	TC Time	-15	

MUD PROPERTIES		Primary		2	3	Program Targets		Essential Program Properties	
Source		Pits, Unscr	Pits, Unscr						
Time		07:45	11:15						
FL Temp	Deg F	32	32						
Depth	m	393.0	624.0			P 2 3	130.1	650.1	
Weight	ppg	8.7	8.7						
FV @ 66	Deg F sec/qt	114	171					100	>
FV @ 120	Deg F cP	11	28						
YP	lbs/100 ft ²	71	62					40	>
Gels	lbs/100 ft ²	27/35	58/66						
API Filt.	ml/30 min	0.0	0.0						
HTHP @ 250	Deg F ml/30 min	0.0	0.0						
Cake API/HTHP	32nd in	0/0	0/0						
Corr. Solids % by vol		0.0	0.0						
Oil/Water % by vol		0.0/0.0	0.0/0.0						
Sand % by vol									
NBT		0.0	0.0						
pH STRIP		10.5	10.8						
Alk. Mud (Pa)		0.00	0.00						
Alk. Filt. (PF/ME)		0.00/0.00	0.00/0.00						
Chlorides mg/l		0	0						
Hard. Ca mg/l		0	0						
Low Gravity Solids ppb		0.00	0.00						

MUD TREATMENTS
 Pumped 15-25 bbl hi-vis lime-flocculated gel sweeps every 15 m or as required. Increased gel content of sweeps so as to utilize remaining bulk gel as instructed. Pumped 50 bbls hi-vis prior to wiper trip. Displaced hole with 375 bbls of hi-vis gel mud - 150% open hole volume. Dumped 86 bbls gel mud from pits #2 and #3. 393 bbls of flocced gel mud still in pit #1. Mixed 396 bbls of EZ-MUD/Polymer fluid - requires salt & barite. Volume and cost of EZ-MUD/Polymer mud considered tomorrow.

RIG ACTIVITY
 Continued drilling 12 1/4" hole with seawater and hi-vis sweeps. Drilled to 650 m, circulated and made wiper trip. Pumped 50 bbl hi-vis sweep and then displaced hole with 150% OH volume of hi-vis gel mud. Pulled out of hole and rigged to run 9 5/8" casing. Running 9 5/8" casing.

MATERIALS USED				SOLIDS EQUIPMENT					
Product	Used	Cost	Product	Used	Cost	Device	Make	Sz/Scrn	HR
AQUAGEL - 100 LB. BAG	485	12522.70				Shkr #1	Brandt	20	
caustic soda - 25 KG. PAIL	11	574.64				Shkr #2	Brandt	10	
lime - 20 KG. BAG	11	137.72				Shkr #3	Brandt	20	
						Shkr #4	Thule	120/52	
						Shkr #5	Thule	120/52	
						Shkr #6	Thule	52/52	
						dSndr		3 X 12	
						dSlt #1		16 X 4	

MUD MANAGEMENT		MUD TYPE		RHEOLOGY AND HYDRAULICS		FRACTURE GRADIENT		TIME	
Hole	Pits	SRAMATER/HI VIS SWEEPS		600 rpm	93 118	Water Depth	54.8	DRIG	11.50
363	-363	MUD CONSUMPTION		300 rpm	82 90	Calc. F. Grad	0.0	CIRC	0.25
Active Volume		ADDITIONS	bbl	200 rpm	76 81	Leak Off Test	0.0	TRIPS	0.00
0		Oil		100 rpm	67 72	ECD	PPG	SERV. RIG	0.00
Reserve	Total	Brine Water	0	6 rpm	26 62	Csg. Shoe	8.8	SURVEY	0.25
393	393	Drill Water	1154	3 rpm	20 57	TD	9.6	FISHING	0.00
Low Grav. vol %	0.0	Sea Water	285	Pressure Units:	psig	Max. Diff. Press	0	LOGGING	0.00
ppb	0.00	Whole Mud	0	Press Drop. DP	0			RUN CSG	12.00
High Grav. vol %	0.0	Barite	0	Press Drop. BIT	0			CORE	0.00
ppb	0.00	Chemicals	57	Press Drop. ANN	0			BACK REAM	0
ASG		LOSSES	bbl	Actual Circ. Press	2050	DEVIATION INFO		REAMING	0.00
Drill Cuttings	245	Dumped	86	AV, DP	ft/min 32	MD	650.0 m	TESTING	0.00
Dilution Rate	0.00	Lost	1017	AV, DC	ft/min 168	TVD	650.0 m	OTHER	0.00
Slids Control Eff	0.00	VOL GAIN/LOSS	393	AV, Riser	ft/min	Angle	0.25	AVERAGE ROP	44.61
						Direction			
						Horiz. Displ	0.0 m		

BAROID REPRESENTATIVE	OFFICE/HOME	Cheltenham, Vic	TELEPHONE	03 9581 7555	DAILY COST	CUMULATIVE COST
Tony Kowalski / Innes Macleod	WAREHOUSE	Barry Beach	TELEPHONE	03 5688 1445	\$A 13235.00	\$A 16720.74

NOTE: ALL COSTS ARE REPORTED IN AUSTRALIA'S DOLLAR
 The recommendations made hereon shall not be construed as authorizing the infringement of any valid patent, and are made without assumption of any liability by BAROID DRILLING FLUIDS, INC. or its agents, and are statements of opinion only.

Baroid Australia Pty Ltd
DRILLING MUD REPORT
(Cost Modified)

REPORT NUMBER: 5

Date	13/10/99	Depth	650.0 m [MD]
Spud Date	11/10/99	Present Activity	TEST BOP

OPERATOR Cultus Petroleum N.L.	CONTRACTOR Sedco Forex	RIG NUMBER 702
REPORT FOR Ray Kohut / Wally Westman	REPORT FOR L. Macracken / R. Nagle	REGION Victoria
WELL NAME AND NUMBER Baleen-2	FIELD OR BLOCK VIC/RL5	GEOGRAPHIC AREA Bass Strait
		COUNTRY Austral

BIT DATA			DRILLING STRING			CASING			CIRCULATION DATA					
Size	in.	Pipe OD	ID	Len.	m	in.	m	Pump Make/Model	Oilwell	A1700PT				
Type		Pipe OD	ID	Len.		20	Riser	80.7	Size	6 X 12	Eff.	97.00	V/st	0.102
No. Jets		Pipe OD	ID	Len.		30	Set @	125.7	spm	0	bbl/min		0.0	
Jets 32nd inch		Collar OD	ID	Len.		9 5/8	Set @	646.4	Pump Make/Model	Oilwell	A1700PT			
		Collar OD	ID	Len.			Set @		Size	6 X 12	Eff.	97.00	V/st	0.102
			in. OPEN HOLE											
							Set @		spm	0	bbl/min		0.0	
Tot Moz Area		Size	12.25	Len.	3.6		Set @		Pump Make/Model	Oilwell	A1700PT			
TPA		Size		Len.			Set @		Size	6 X 12	Eff.	97.00	V/st	0.102
		Size		Len.			Set @		spm	0	bbl/min		0.0	
		Size		Len.			Set @		Tot. Vol./min	0	gpm	0.0	bbl	
		Size		Len.			Set @		BU Time	0	TC Time	0		

MUD PROPERTIES					MUD TREATMENTS				
	Primary	2	3						
Source	Pits, Oncr	Flowline		Program	Essential	Added salt, DEXTRID and barite to new polymer mud in pit #3 and blended in with previously mixed EZ-MUD/Polymer kill mud.			
Time	09:30	19:00		Targets	Program	Properties as per 09:30 mud check. Treated to reduce HMIT which will be reduced further when drilling. Properties as per 19:00 mud check. Will add balance of EZ-MUD plus Sodium Nitrate following displacement.			
FL Temp	Deg F	32	32	*=Excep	Properties	845 bbls salt/polymer mud in pits #2 and #3			
Depth	m	650.0	650.0	P 2 3	130.1 650.1	342 bbls of flocced hi-vis gel mud in pit #1			
Weight	PPG	10.1	10.1			14 bbls "dead" salt/polymer volume in pit #4. Losses are hi-vis gel from cement job.			
FV @ 66	Deg F sec/qt	47	47			RIG ACTIVITY			
FV @ 120	Deg F cP	12	16			Ran 9 5/8" casing and cemented at 646.4 m.			
YP	lbs/100 ft3	19	26			Ran and tested BOP's and riser.			
Cele	lbs/100 ft3	4/6	4/6						
API Filt.	ml/30 min	4.5	4.0						
HTHP @ 250	Deg F ml/30 min	22.6	18.0						
Cake API/HTHP	32nd in	1/2	1/2						
Corr.Solids % by vol		5.1	5.1						
Oil/Water % by vol		0.0/92.0	0.0/92.0						
Sand % by vol		Nil	Nil						
NBT		0.0	0.0						
pH STRIP		9.6	9.6						
Alk. Mud (Pa)		0.25	0.25						
Alk. Filt. (PE/ME)		0.03/0.09	0.04/0.10						
Chlorides mg/l		51000	51000						
Hard. Ca mg/l		220	200						
Low Gravity Solids ppb		2.28	2.28						
Nitrate mg/l		Nil	Nil						
NaCl Content % vol		8.0	8.0						

MATERIALS USED				SOLIDS EQUIPMENT			
Product	Used	Cost		Product	Used	Cost	
DEXTRID LT - 25 KG. BAG	40	2567.60		Shkr #1	Brandt	20	
EZ MUD DP - 50 LB. SACK	6	838.56		Shkr #2	Brandt	10	
PAC-R - 25 KG. BAG	14	2511.60		Shkr #3	Brandt	20	
Sodium Chloride - 1000 KG. B	7.248	3142.73		Shkr #4	Thule	120/52	
XCD Polymer - 25 KG. BAG	11	5048.67		Shkr #5	Thule	120/52	
barite - 100 LB. BULK	597.000	8889.33		Shkr #6	Thule	52/52	
caustic soda - 25 KG. PAIL	3	156.72		d8ndr		3 x 12	
soda ash - 25 KG. BAG	3	53.52		dslt #1		16 x 4	

MUD MANAGEMENT			RHEOLOGY AND HYDRAULICS			FRACTURE GRADIENT TIME			
MUD VOLUME	bbbl	MUD TYPE			Water Depth	54.8	DRIG	0.00	
Hole	Pits	NACL/EZ-MUD/POLYMER	600 rpm	43 58	Calc. F. Grad	0.0	CIRC	0.00	
228	-228		300 rpm	31 42	Leak Off Test	0.0	TRIPS	2.25	
Active Volume		MUD CONSUMPTION	200 rpm	25 33	ECD	ppg	SERV. RIG	0.00	
0		Oil	100 rpm	18 23	Ceg. Shoe	0.0	SURVEY	0.00	
Reserve	Total	Brine Water	0	6 rpm 6 6	TD	0.0	FISHING	0.00	
1201	1201	Drill Water	805	3 rpm 3 4	Max. Diff. Press	0	LOGGING	0.00	
Low Grav. vol %	0.3	Sea Water	0	Pressure Units: psig			RUN CSG	4.75	
ppb	2.28	Whole Mud	0	Press Drop. DP	0		CORE	0.00	
High Grav. vol %	4.9	Barite	41	Press Drop. BIT	0	DEVIATION INFO			
ppb	72.03	Chemicals	13	Press Drop. ANN	0	MD	650.0 m	REAMING	0.00
ASG	4.22	LOSSES	bbl	Actual Circ. Press	0	TVD	650.0 m	TRSTING	0.00
Drill Cuttings	0	Dumped	0	AV, DP ft/min	0	Angle	0.25	OTHER	17.00
Dilution Rate	0.00	Lost	51	AV, DC ft/min	0	Direction		AVERAGE ROP	0.00
Slide Control Eff	0.00	VOL GAIN/LOSS	808	AV, Riser ft/min		Horiz. Displ	0.0 m		
BAROID REPRESENTATIVE	OFFICE/HOME	Cheltenham, Vic	TELEPHONE	03 9581 7555	DAILY COST	CUMULATIVE COST			
Tony Kowalski / Innes Macleod	WAREHOUSE	Barry Beach	TELEPHONE	03 5688 1445	\$A	23208.73	\$A	39929.47	

NOTE: ALL COSTS ARE REPORTED IN AUSTRALIA'S DOLLAR

The recommendations made hereon shall not be construed as authorizing the infringement of any valid patent, and are made without assumption of any liability by BAROID DRILLING FLUIDS, INC. or its agents, and are statements of opinion only.

Baroid Australia Pty Ltd
DRILLING MUD REPORT
(Cost Modified)

REPORT NUMBER: 6

Date	Depth
14/10/99	746.0 m [MD]
Spud Date	Present Activity
11/10/99	POOH

OPERATOR Cultus Petroleum N.L.	CONTRACTOR Sedco Forex	RIG NUMBER 702
REPORT FOR Ray Kohut / Wally Westman	REPORT FOR L. Macracken / R. Nagle	REGION Victoria
WELL NAME AND NUMBER Baleen-2	FIELD OR BLOCK VIC/RL5	GEOGRAPHIC AREA Bass Strait
		COUNTRY Austral

BIT DATA		DRILLING STRING			CASING		CIRCULATION DATA			
Size 8.5 in.	Pipe OD	S	ID 4.276	Len. 285.3	in.	m	Pump Make/Model	Oilwell A1700PT		
Type REED MH13G	Pipe OD	5	ID 3.000	Len. 138.6	20	Riser 80.7	Size 6 X 12	Eff. 97.00	V/st 0.102	
No. Jets	Pipe OD	ID	Len.		30	Set @ 125.7	spm 0	bbl/min 0.0		
Jets 32nd inch		Collar OD	6.5	ID 2.813	Len. 156.1	9 5/8	Set @ 646.4	Pump Make/Model	Oilwell A1700PT	
18	18	18	Collar OD	ID	Len.		Set @	Size 6 X 12	Eff. 97.00	V/st 0.102
		in. OPEN HOLE			m		Set @	spm 75	bbl/min 7.6	
Tot Moz Area		Size 12.25	Len. 3.6			Set @	Pump Make/Model	Oilwell A1700PT		
TPA		Size 8.5	Len. 96.0			Set @	Size 6 X 12	Eff. 97.00	V/st 0.102	
		Size	Len.			Set @	spm 75	bbl/min 7.6		
		Size	Len.			Set @	Tot. Vol./min 641 gpm 15.3 bbl			
		Size	Len.			Set @	BU Time 10	TC Time 43		

MUD PROPERTIES				MUD TREATMENTS	
Source	Flowline	Pits, Circ	Program	Essential Program Properties	
Time	18:30	13:00	Targets		
FL Temp	Deg F 93	81	*-Excep		
Depth	m 714.0	666.0	P 2 3	650.1	925.1
Weight	ppg 10.1	10.1		10.0	10.5
FV @ 81 Deg F	sec/qt 47	49			
FV @ 77 Deg F	cp 22	16			
YP	lbs/100 ft ² 20	22			
Gels	lbs/100 ft ² 5/6	5/8			
API Filt.	ml/30 min 3.6	3.8		<	6.0
HTHP @ 250 Deg F	ml/30 min 16.0	16.8	* *	<	15.0
cake API/HTHP	32nd in 1/2	1/2			
Corr.Solids % by vol	5.6	5.5			
Oil/Water % by vol	0.0/91.8	0.0/91.8			
Sand % by vol	0.5	0.5			
MBT	0.6	0.6			
pH STRIP	9.0	9.4		8.5	9.5
Alk. Mud (Pm)	0.20	0.23			
Alk. Filtr. (RE/ME)	0.02/0.08	0.03/0.08			
Chlorides mg/l	45500	48500		38000	51000
Hard. Ca mg/l	180	280			
Low Gravity Solids ppb	8.46	7.10		<	73.00
6 rpm	8	8		8.00	10.00
NaCl Content % vol	7.5	7.9			
Excess PHPA ppb	1.3	0.70			

Drilled out cement with seawater and circulated a 50 bbl hi-vis gel sweep displaced with seawater and then displaced to NaCl/EZ-MUD/Polymer fluid-no losses. Added sodium nitrate and increased EZ-MUD concentration to 0.7 ppb. Lost approximately 45 bbls over Thule and scalper shakers. Halted polymer addition and then added remainder at 45 mins/sack. Downsized Thule shaker screens to 120 mesh. Dumped volume is hi-vis gel. Built 40 bbls NaCl/EZ-MUD/Polymer pre-mix for volume.

RIG ACTIVITY

Continued testing BOP'S. Made up 8 1/2" bit and BHA and ran in hole. Tagged TOC at 596 m and drilled shoe track Pumped 50 bbl hi-vis gel sweep followed by 50 bbls of seawater and then displaced hole to salt polymer mud. Drilled 4 m new hole to 654 m and carried out LOT to an RMW of 15.1 ppg. Resumed drilling 8 1/2" hole to 746m, circulating samples up to pick core point. POOH to core. Nitrates=400 mg/l

MATERIALS USED			SOLIDS EQUIPMENT		
Product	Used	Cost	Product	Used	Cost
DEXTRID LT - 25 KG. BAG	2	128.38			
EZ MUD DP - 50 LB. SACK	11	1537.36			
PAC-R - 25 KG. BAG	1	179.40			
XCD Polymer - 25 KG. BAG	2	917.94			
barite - 100 LB. BULK	50.000	744.50			
soda ash - 25 KG. BAG	1	17.84			
sodium nitrate - 25 KG. BAG	7	337.75			

Device	Make	Sz/Screen	HR
Shkr #1	Brandt	20	18
Shkr #2	Brandt	10	18
Shkr #3	Brandt	20	18
Shkr #4	Thule	120	18
Shkr #5	Thule	120	18
Shkr #6	Thule	120	18
dSndr		3 x 12	
dSlt #1		16 x 4	

MUD MANAGEMENT		MUD TYPE		RHEOLOGY AND HYDRAULICS		FRACTURE GRADIENT TIME	
Hole	Pits	NACL/EZ-MUD/POLYMER		600 rpm	64 54	Water Depth	54.8
220	484	MUD CONSUMPTION		300 rpm	42 38	Calc. F. Grad	0.0
Active Volume		ADDITIONS	bbl	200 rpm	33 32	Leak Off Test	15.1
704		Oil	0	100 rpm	22 24	RCD	PPG
Reserve	Total	Brine Water	0	6 rpm	8 8	Ceg. Shoe	10.9
395	1099	Drill Water	36	3 rpm	5 5	TD	10.8
Low Grav, vol %	0.9	Sea Water	0	Pressure Units:	paig	Max. Diff. Press	0
ppb	8.46	Whole Mud	0	Press Drop. DP	836		
High Grav, vol %	4.7	Barite	3	Press Drop. BIT	683		
ppb	69.09	Chemicals	1	Press Drop. ANN	94		
ASG	4.02	LOSSES	bbl	Actual Circ. Press	1525		
Drill Cuttings	22	Dumped	53	AV, DP	ft/min 48		
Dilution Rate	0.50	Lost	89	AV, DC	ft/min 475		
Slide Control Eff	60.00	VOL GAIN/LOSS	-102	AV, Riser	ft/min 48		

BAROID REPRESENTATIVE Tony Kowalski / Innes Macleod	OFFICE/HQMS Cheltenham, Vic	TELEPHONE 03 9581 7555	DAILY COST \$A 3863.17	CUMULATIVE COST \$A 43792.64
WAREHOUSE Barry Beach	TELEPHONE 03 5688 1445			

NOTE: ALL COSTS ARE REPORTED IN AUSTRALIA'S DOLLAR
The recommendations made hereon shall not be construed as authorizing the infringement of any valid patent, and are made without assumption of any liability by BAROID DRILLING FLUIDS, INC. or its agents, and are statements of opinion only.

Baroid Australia Pty Ltd
DRILLING MUD REPORT
(Cost Modified)

REPORT NUMBER: 7

Date	15/10/99	Depth	780.0 m [MD]
Spud Date	11/10/99	Present Activity	POOH WITH CORE #2

OPERATOR Cultus Petroleum N.L.	CONTRACTOR Sedco Forex	RIG NUMBER 702
REPORT FOR Ray Kohut / Wally Westman	REPORT FOR L. Macracken / R. Nagle	REGION Victoria
WELL NAME AND NUMBER Baleen-2	FIELD OR BLOCK VIC/RL5	GEOGRAPHIC AREA Bass Strait
		COUNTRY Austral

BIT DATA		DRILLING STRING			CASING		CIRCULATION DATA		
Size 8.5 in.	in.	Pipe OD	ID	Len.	in.	Riser 80.7	Pump Make/Model	Oilwell A1700FT	
Type DBS	CD-73	Pipe OD	ID	Len.	20	Set @ 125.7	Size 6 X 12	Eff. 97.00	V/st 0.102
No. Jets		Pipe OD	ID	Len.	30	Set @ 646.4	rpm 45	bbl/min 4.6	
Jets 32nd inch		Collar OD	ID	Len.	9 5/8	Set @ 646.4	Pump Make/Model	Oilwell A1700FT	
		Collar OD	ID	Len.		Set @	Size 6 X 12	Eff. 97.00	V/st 0.102
		in. OPEN HOLE				Set @	rpm 0	bbl/min 0.0	
Tot Moz Area		Size 12.25	Len. 3.6		Set @	Pump Make/Model	Oilwell A1700FT		
TFA		Size 8.5	Len. 130.0		Set @	Size 6 X 12	Eff. 97.00	V/st 0.102	
		Size	Len.		Set @	rpm 0	bbl/min 0.0		
		Size	Len.		Set @	Tot. Vol./min	192 gpm	4.6 bbl	
		Size	Len.		Set @	SU Time	0	TC Time	98

MUD PROPERTIES			MUD TREATMENTS			
Source	Flowline	Pits, Circ	Program Targets	Essential Program Properties		Nitrates, mg/l: Test 1 = 480, Test 2 = 520 Bled new volume premix into active while circulating prior to coring. Adjusted pH and added XCD-Polymer to maintain 6 rpm reading of 8. 5.7% gas while cutting core-no reduction in mud weight.
Time	20:00	08:00				
FL Temp	Deg F	81	84			
Depth	m	777.0	763.0	P 2 3	650.1 925.1	
Weight	PPG	10.1	10.1		10.0 10.5	
FV @ 81 Deg F	sec/qt	51	52			
FV @ 120 Deg F	cP	22	18			
YP	lbs/100 ft2	25	25			
Gels	lbs/100 ft2	5/6	4/6			
API Filt.	ml/30 min	3.6	3.7		< 6.0	
HTMP @ 250 Deg F	ml/30 min	14.8	15.4	*	< 15.0	
Cake API/HTMP	32nd in	1/2	1/2			
Corr. Solids % by vol		7.1	6.8			
Oil/Water % by vol		0.0/90.5	0.0/90.6			
Sand % by vol		0.5	0.35			
MBT		1.2	0.9			
pH STRIP		8.7	8.8		8.5 9.5	
Alk. Mud (Pm)		0.20	0.20			
Alk. Filtr. (PF/MF)		0.01/0.06	0.02/0.06			
Chlorides mg/l		44000	47000		38000 51000	
Hard. Ca mg/l		160	240			
Low Gravity Solids ppb		33.12	29.94		< 73.00	
6 rpm		8	8		8.00 10.00	
NaCl Content % vol		6.9	7.7			
Excess PHPA ppb		0.9	1.1			

RIG ACTIVITY			
Finished pulling out of hole.			
Made up core barrel and ran back in hole.			
Circulated and dropped ball.			
Cut core #1 from 646-763 m. POOH and recovered core. RIH, circulated and dropped ball.			
Cut core #2 from 763-780 m. POOH with core #2.			

MATERIALS USED			SOLIDS EQUIPMENT		
Product	Used	Cost	Product	Used	Cost
XCD Polymer - 25 KG. BAG	1	458.97			
caustic soda - 25 KG. PAIL	2	104.48			
soda ash - 25 KG. BAG	1	17.84			

Device	Make	Sz/Scrn	HR
Shkr #1	Brandt	20	10
Shkr #2	Brandt	10	10
Shkr #3	Brandt	20	10
Shkr #4	Thule	120	10
Shkr #5	Thule	120	10
Shkr #6	Thule	120	10
dSndr		3 x 12	
dSlt #1		16 x 4	

MUD MANAGEMENT			RHEOLOGY AND HYDRAULICS			FRACTURE GRADIENT		TIME	
MUD VOLUME	MUD TYPE		MUD CONSUMPTION			Water Depth	54.8	DRIG	0.00
Hole 258	Pits 447	NACL/EZ-MUD/POLYMER	600 rpm	69	61	Calc. F. Grad	0.0	CIRC	1.75
Active Volume 705		ADDITIONS	300 rpm	47	43	Leak Off Test	15.1	TRIPS	17.75
Reserve 382	Total 1087	Oil	200 rpm	40	34	XCD	PPG	SERV. RIG	0.00
Low Grav. vol % 3.6		Brine Water	100 rpm	27	24	Ceg. Shoe	10.7	SURVEY	0.00
ppb 33.12		Drill Water	6 rpm	8	8	TD	10.8	FISHING	0.00
High Grav. vol % 3.4		Sea Water	3 rpm	5	5	Max. Diff. Press	0	LOGGING	0.00
ppb 49.98		Whole Mud	Pressure Units:		psig			RUN CSG	0.00
ASG 3.44		Barite	0 Press Drop. DP		0	DEVIATION INFO			
Drill Cuttings 0		Chemicals	0 Press Drop. BIT		0	MD	780.0 m	BACK REAM	0.00
Dilution Rate 0.00		LOSSES	0 Press Drop. ANN		0	TVD	780.0 m	REAMING	0.00
Slide Control Eff 60.00		Dumped	Actual Circ. Press		550	Angle	0.00	TESTING	0.00
		Lost	0 AV, DP	ft/min	0	Direction		OTHER	0.25
		VOL GAIN/LOSS	12 AV, DC	ft/min	65	Horiz. Displ	0.0 m	AVERAGE ROP	0.00
			14 AV, Riser	ft/min	14				
BAROID REPRESENTATIVE	OFFICE/HOME	Cheltenham, Vic	TELEPHONE	03 9581 7555		DAILY COST		CUMULATIVE COST	
Tony Kowalski / Innes Macleod	WAREHOUSE	Barry Beach	TELEPHONE	03 5688 1445		\$A 581.25		\$A 34373.99	

NOTE: ALL COSTS ARE REPORTED IN AUSTRALIA'S DOLLAR

The recommendations made hereon shall not be construed as authorizing the infringement of any valid patent, and are made without assumption of any liability by BAROID DRILLING FLUIDS, INC. or its agents, and are statements of opinion only.

Baroid Australia Pty Ltd
DRILLING MUD REPORT

REPORT NUMBER: 8

Date	16/10/99	Depth	895.0 m [MD]
Spud Date	11/10/99	Present Activity	WIRELINE LOGGING

OPERATOR Cultus Petroleum N.L.	CONTRACTOR Sedco Forex	RIG NUMBER 702
REPORT FOR Ray Kohut / Wally Westman	REPORT FOR L. Macracken / R. Naqle	REGION Victoria
WELL NAME AND NUMBER Baleen-2	FIELD OR BLOCK VIC/RL5	GEOGRAPHIC AREA Bass Strait
		COUNTRY Austral

BIT DATA		in. DRILLING STRING			CASING		CIRCULATION DATA		
Size 8.5	in.	Pipe OD	ID	Len.	in.	in.	Pump Make/Model	Oilwell A1700FT	
Type REMD	HP-43	Pipe OD	ID	Len.	20	Riser 80.7	Size 6 X 12	Eff. 97.00	V/st 0.102
No. Jets		Pipe OD	ID	Len.	30	Set @ 125.7	spm 70	bbl/min 7.1	
Jets 32nd inch		Collar OD	ID	Len.	9 5/8	Set @ 646.4	Pump Make/Model	Oilwell A1700FT	
14	14	14	Collar OD	ID	Len.	Set @	Size 6 X 12	Eff. 97.00	V/st 0.102
in. OPEN HOLE						Set @	spm 70	bbl/min 7.1	
Tot Noz Area		Size 12.25	Len. 3.6		Set @	Pump Make/Model	Oilwell A1700FT		
TVA		Size 8.5	Len. 245.0		Set @	Size 6 X 12	Eff. 97.00	V/st 0.102	
		Size	Len.		Set @	spm 0	bbl/min 0.0		
		Size	Len.		Set @	Tot. Vol./min	599	gpm 14.3	bbl
		Size	Len.		Set @	BU Time 0	TC Time 42'		

MUD PROPERTIES					MUD TREATMENTS				
	Primary	2	3	Program	Essential				
Source	Flowline	Pits	Circ	Targets	Program	Nitrates, mg/l: Test #1=440, #2=400			
Time	13:50	07:45		*-Excep	Properties	Used air pump to transfer "dead" volume from pit #3 to active. Transferred slug pit volume to active.			
FL Temp	Deg F	95	82	P 2 3	650.1 925.1	Mixed 189 bbls new volume as active volume was low and possible downhole losses were anticipated-blend into active system.			
Depth	m	895.0	787.0			Lost 15 bbls in 1/2 hr during fast drilling from 855-870 m.			
Weight	ppg	10.1	10.1		10.0 10.5				
FV @ 79 Deg F	sec/qt	49	53						
FV @ 120 Deg F	cP	18	18						
YP	lbs/100 ft2	27	26						
Gels	lbs/100 ft2	5/8	5/6						
API Filt.	ml/30 min	3.4	3.2		< 6.0				
HTHP @ 250 Deg F	ml/30 min	14.8	15.0		< 15.0				
Cake API/HTHP	32nd in	1/2	1/2						
Corr. Solids % by vol		6.6	6.4						
Oil/Water % by vol		0.0/90.0	0.0/91.0			RIG ACTIVITY			
Sand % by vol		0.65	0.55			Pulled out of hole and recovered core #2. Ran back in hole with a 1/2" bit. Reamed core hole from 646 m to bottom. Drilled to TD at 895 m. Circulated 2 times bottom up (shakers clean) and pulled out of hole.			
MBT		1.1	1.0			Rigged up Schlumberger and running wireline logs at report time.			
pH STRIP		9.0	8.9		8.5 9.5				
Alk. Mud (Pa)		0.47	0.27						
Alk. Filtr. (PE/ME)		0.04/0.09	0.02/0.06						
Chlorides mg/l		46500	47000		38000 51000				
Hard. Ca mg/l		200	180						
Low Gravity Solids ppb		26.48	22.57		< 73.00				
c rpm		8	7		8.00 10.00				
NaCl Content % vol		7.6	7.2						
Excess PHPA ppb		1.0	0.9						

MATERIALS USED

Product	Used	Cost	Product	Used	Cost	SOLIDS EQUIPMENT			
DETRID LT - 25 KG. BAG	8	513.52				Shkr #1	Brandt	20	
PAC-R - 25 KG. BAG	3	538.20				Shkr #2	Brandt	10	14
Sodium Chloride - 1000 KG. B	2.035	882.38				Shkr #3	Brandt	20	14
XCD Polymer - 25 KG. BAG	3	1376.91				Shkr #4	Thule	120	13
barite - 100 LB. BULK	100.000	1489.00				Shkr #5	Thule	120	13
caustic soda - 25 KG. PAIL	2	104.48				Shkr #6	Thule	120	14
soda ash - 25 KG. BAG	1	17.84				dSndr		3 x 12	
sodium nitrate - 25 KG. BAG	1	48.25				dSlit #1		16 x 4	

MUD MANAGEMENT

MUD VOLUME	MUD TYPE	RHEOLOGY AND HYDRAULICS			FRACTURE GRADIENT		TIME		
Hole	Pits	600 rpm	63	62	Water Depth	54.8	DRIG	6.00	
284	601	300 rpm	45	44	Calc. F. Grad	0.0	CIRC	2.00	
Active Volume		200 rpm	37	36	Leak Off Test	15.1	TRIPS	6.75	
885		100 rpm	25	25	ECD	PPG	SERV. RIG	0.00	
Reserve	Total	6 rpm	8	7	Ceg. Shoe	10.8	SURVEY	0.00	
342	1227	3 rpm	5	5	TD	11.1	FISHING	0.00	
Low Grav. vol %	2.9	Pressure Units:	psig		Max. Diff. Press	0	LOGGING	7.00	
ppb	26.48						RUN CSG	0.00	
High Grav. vol %	3.7	Press Drop. DP	0		CORE				
ppb	54.39	Press Drop. BIT	0		BACK REAM				
ASG	3.57	Press Drop. AMN	0		REAMING				
Drill Cuttings	26	Actual Circ. Press	2300		TESTING				
Dilution Rate	0.00	AV, DP	ft/min	0	OTHER				
Slits Control Eff	60.00	AV, DC	ft/min	203	AVERAGE ROP				
		Vol GAIN/LOSS	140	AV, Riser ft/min	45				

BAROID REPRESENTATIVE	OFFICE/HOME	Cheltenham, Vic	TELEPHONE	03 9581 7555	DAILY COST	CUMULATIVE COST	
Tony Kowalski / Innes Macleod	WAREHOUSE	Barry Beach	TELEPHONE	03 5688 1445	\$A	4970.58	\$A 49344.51

NOTE: ALL COSTS ARE REPORTED IN AUSTRALIA'S DOLLAR
The recommendations made hereon shall not be construed as authorizing the infringement of any valid patent, and are made without assumption of any liability by BAROID DRILLING FLUIDS, INC. or its agents, and are statements of opinion only.

Baroid Australia Pty Ltd
DRILLING MUD REPORT

REPORT NUMBER: 9	
Date 17/10/99	Depth 895.0 m [MD]
Spud Date 11/10/99	Present Activity WIRELINE LOGGING

OPERATOR Cultus Petroleum N.L.	CONTRACTOR Sedco Forex	RIG NUMBER 702
REPORT FOR Ray Kohut / Wally Westman	REPORT FOR L. Macracken / R. Nagle	REGION Victoria

WELL NAME AND NUMBER Baleen-2	FIELD OR BLOCK VIC/RL5	GEOGRAPHIC AREA Bass Strait	COUNTRY Austral
----------------------------------	---------------------------	--------------------------------	--------------------

BIT DATA				DRILLING STRING				CASING				CIRCULATION DATA				
Size in.	Pipe OD	ID	Len.	in.	ID	Len.	in.	Riser	80.7	Pump Make/Model	Oilwell A1700PT	Size 6 X 12	Eff.	97.00	V/st	0.102
Type	Pipe OD	ID	Len.	30	Set @	125.7	30	Set @	0	rpm	0	bbbl/min	0	0.0		
No. Jets	Pipe OD	ID	Len.	9 5/8	Set @	646.4		Set @		Pump Make/Model	Oilwell A1700PT	Size 6 X 12	Eff.	97.00	V/st	0.102
Jets 32nd inch	Collar OD	ID	Len.		Set @			Set @		rpm	0	bbbl/min	0	0.0		
	Collar OD	ID	Len.		Set @			Set @		Pump Make/Model	Oilwell A1700PT	Size 6 X 12	Eff.	97.00	V/st	0.102
				OPEN HOLE												
Tot Moz Area	Size	12.25	Len.	3.6	Set @			Set @		rpm	0	bbbl/min	0	0.0		
TFA	Size	8.5	Len.	245.0	Set @			Set @		Pump Make/Model	Oilwell A1700PT	Size 6 X 12	Eff.	97.00	V/st	0.102
	Size		Len.		Set @			Set @		rpm	0	bbbl/min	0	0.0		
	Size		Len.		Set @			Set @		Tot. Vol./min	0	gpm	0.0	bbbl		
	Size		Len.		Set @			Set @		BU Time	0	TC Time	0			

MUD PROPERTIES		Primary	2	3	MUD TREATMENTS	
Source	Pits, Unscr				Program Targets	Essential Program Properties
Time	10:00				*-Excep	
FL Temp	Deg F	32			P 2 3	650.1 925.1
Depth	m	895.0				10.0 10.5
Weight	ppg	10.1				
FV @ 68 Deg F	sec/qt	50				
FV @ 120 Deg F	cP	17				
YP	lbs/100 ft ²	25				
Gels	lbs/100 ft ²	5/7				
API Filtr.	ml/30 min	3.6				
HTHP @ 482 Deg F	ml/30 min	15.4				< 6.0
Cake API/HTHP	32nd in	1/2				< 15.0
Corr.Solids % by vol		6.2				
Oil/Water % by vol		0.0/91.2				
Sand % by vol		0.50				
NBT		1.0				
pH STRIP		9.0				8.5 9.5
Alk. Mud (Pm)		0.38				
Alk. Filtr. (P/MF)		0.03/0.07				
Chlorides mg/l		46500				38000 51000
Hard. Ca mg/l		190				
Low Gravity Solids ppb		19.11				< 73.00
6 rpm		7				8.00 10.00
NaCl Content % vol		7.6				
Excess PHPA ppb		1.0				

MUD TREATMENTS

Nitrates, mg/l: 400

2 sacks calcium chloride to be used in mix water for P & A cement plugs.

1 can BARACIDE and 1 pail caustic soda to be used to inhibit mud to be left in casing when P & A.

20 mt NaCl to be dumped overboard as per instructions.

The above chemical usage will be charged to non-drilling operations.

58 bbls dumped from pit #4 and slug pit.

RIG ACTIVITY

Continued wireline logging.

MATERIALS USED

Product	Used	Cost	Product	Used	Cost	SOLIDS EQUIPMENT		
BARACIDE - 25 KG. CAN	1	521.89				Device	Make	Sz/Scrn HR
Sodium Chloride - 1000 KG. B	20.000	8672.00				Shkr #1	Brandt	20
calcium chloride - 25 KG. BA	2	35.06				Shkr #2	Brandt	10
caustic soda - 25 KG. PAIL	1	52.24				Shkr #3	Brandt	20
						Shkr #4	Thule	120
						Shkr #5	Thule	120
						Shkr #6	Thule	120
						dSndr		3 x 12
						dSlt #1		16 x 4

MUD MANAGEMENT		MUD TYPE		RHEOLOGY AND HYDRAULICS		FRACTURE GRADIENT		TIME	
MUD VOLUME bbl	MUD TYPE	NACL/EE-MUD/POLYMER		600 rpm	59	Water Depth	\$4.8	DRIG	0.00
Hole	Pits			300 rpm	42	Calc. F. Grad	0.0	CIRC	0.00
284	594			200 rpm	34	Leak Off Test	15.1	TRIPS	0.00
Active Volume				100 rpm	24	BCD	PPG	SERV. RIG	0.00
878				6 rpm	7	Ceg. Shoe	0.0	SURVEY	0.00
Reserve	Total			3 rpm	5	TD	0.0	FISHING	0.00
284	1162			Pressure Units:	paig	Max. Diff. Press	0	LOGGING	24.00
Low Grav, vol %	2.1			Press Drop. DP	0			RUN CSG	0.00
ppb	19.11			Press Drop. BIT	0			CORE	0.00
High Grav, vol %	4.1			Press Drop. AMM	0			BACK REAM	0.00
ppb	60.27			Actual Circ. Press	0	DEVIATION INFO			
ASG	3.74			AV, DP	ft/min	MD	895.0 m	REAMING	0.00
Drill Cuttings	0			AV, DC	ft/min	TVD	895.0 m	TESTING	0.00
Dilution Rate	0.00			-66 AV, Riser	ft/min	Angle	0.00	OTHER	0.00
Slide Control Eff	0.00					Direction		AVERAGE ROP	0.00
						Horiz. Displ	0.0 m		

BAROID REPRESENTATIVE Tony Kowalski / Innes Macleod	OFFICE/PHONE Cheltenham, Vic	TELEPHONE 03 9581 7555	DAILY COST \$A	CUMULATIVE COST \$A 56625.70
	WAREHOUSE Baitty Beach	TELEPHONE 03 8688 1445		

NOTE: ALL COSTS ARE REPORTED IN AUSTRALIA'S DOLLAR

The recommendations made hereon shall not be construed as authorizing the infringement of any valid patent, and are made without assumption of any liability by BAROID DRILLING FLUIDS, INC. or its agents, and are statements of opinion only.

Baroid Australia Pty Ltd
DRILLING MUD REPORT

REPORT NUMBER: 10

Date	Depth
18/10/99	895.0 m [MD]
Spud Date	Present Activity
11/10/99	PLUG & ABANDON

OPERATOR Cultus Petroleum N.L.	CONTRACTOR Sedco Forex	RIG NUMBER 702
REPORT FOR Ray Kohut / Wally Westman	REPORT FOR L. Macracken / R. Nagle	REGION Victoria
WELL NAME AND NUMBER Baleen-2	FIELD OR BLOCK VIC/RL5	GEOGRAPHIC AREA Bass Strait
		COUNTRY Austral

BIT DATA		DRILLING STRING			CASING		CIRCULATION DATA		
Size in.	Pipe OD	ID	Len.	in.	in.	Pump Make/Model	Oilwell A1700PT	Size	6 X 12
Type	Pipe OD	ID	Len.	20	Riser	80.7	Eff.	97.00	V/st
No. Jets	Pipe OD	ID	Len.	30	Set @	125.7	spm	0	bbl/min
Jets 32nd inch	Collar OD	ID	Len.	9 5/8	Set @	646.4	Pump Make/Model	Oilwell A1700PT	
	Collar OD	ID	Len.		Set @		Size	6 X 12	Eff.
					Set @		spm	0	bbl/min
	in. OPEN HOLE				Set @				
TOC Moz Area	Size	12.25	Len.	3.6	Set @		Pump Make/Model	Oilwell A1700PT	
TVA	Size	8.5	Len.	245.0	Set @		Size	6 X 12	Eff.
	Size		Len.		Set @		spm	0	bbl/min
	Size		Len.		Set @		Tot. Vol./min	0	gpm
	Size		Len.		Set @			0.0	bbl
	Size		Len.		Set @		BU Time	0	TC Time
								0	0

MUD PROPERTIES					MUD TREATMENTS				
	Primary	2	3						
Source	Pits, Uncon			Program					
Time	16:00			Targets					
Fl Temp	Deg F	32		*-Excep					
Depth	m	895.0		P 2 3	650.1	925.1			
Weight	ppg	10.1			10.0	10.5			
FV @ 60	Deg F sec/qt	52							
FV @ 120	Deg F cP	18							
YP	lbs/100 ft2	26							
Gels	lbs/100 ft2	5/7							
API Filt.	ml/30 min	3.8			<	6.0			
HTHP @ 32	Deg F ml/30 min	0.0			<	15.0			
Cake API/HTHP	32nd in	1/0							
Corr.Solids % by vol		0.0							
Oil/Water % by vol		0.0/0.0							
Sand % by vol									
NBT		0.0							
pH STRIP		9.5			8.5	9.5			
Alk. Mud (Pm)		0.28							
Alk. Filtr. (PE/ME)		0.40/1.00							
Chlorides mg/l		45000			38000	51000			
Hard. Ca mg/l		320							
Low Gravity Solids ppb		0.00			<	73.00			
c rpm		8			8.00	10.00			
NaCl Content	% vol	7.4							
Excess PHPA	ppb	1.0							

Carried out analysis of fluids recovered from wireline sampling.
Nitrates, mg/l: 352
Added previously charged BARACIDE and caustic soda to mud to be left in casing above #2 cement plug.
Previously charged calcium chloride used in mix water for #3 cement plug.
20 mt (5 x 4 mt) bulk NaCl still to be dumped.

MATERIALS USED

RIG ACTIVITY
Continued wireline logging.
Rigged down, picked up tubing and ran in Circulated bottoms up and set cement plug #1 from 890-790 m. Pulled to 760 m and circulated bottoms up-no cement to surface. Set cement plug #2 from 760-660 m and pulled to 550 m and circulated bottoms up -no cement. Pulled out of hole and laid out tubulars. Ran in and tagged TOC #2 cat plug at 580 m. Ran gauge ring and set bridge plug at 180 m. Disp riser to s/w. Cat plug #3 175-125 m. Reverse circ out cement and then convert.

MATERIALS USED				SOLIDS EQUIPMENT			
NO INVENTORY USED ON THIS REPORT				Device	Make	Sz/Scrn	HR
				Shkr #1	Brandt	20	
				Shkr #2	Brandt	10	
				Shkr #3	Brandt	20	
				Shkr #4	Thule	120	2
				Shkr #5	Thule	120	2
				Shkr #6	Thule	120	2
				dSndr		3 x 12	
				dSlt #1		16 x 4	

MUD MANAGEMENT				RHEOLOGY AND HYDRAULICS				FRACTURE GRADIENT TIME				
MUD VOLUME		MUD TYPE										
Hole	Pits	NACL/SE-MUD/POLYMER										
284	-284			600 rpm	62	Water Depth		54.8	DRLO		0.00	
Active Volume		MUD CONSUMPTION		300 rpm	44	Calc. F. Grad		0.0	CIRC		2.00	
0		ADDITIONS		200 rpm	35	Leak Off Test		15.1	TRIPS		12.00	
Reserve	Total	Oil	0	100 rpm	23	ECD		PPG	SERV. RIG		0.00	
878	878	Brine Water	0	6 rpm	8	Ceg. Shoe		0.0	SURVEY		0.00	
Low Grav, vol %	0.0	Drill Water	0	3 rpm	5	TD		0.0	FISHING		0.00	
ppb	0.00	Sea Water	0	Pressure Units:		Max. Diff. Press		0	LOGGING		5.00	
High Grav, vol %	0.0	Whole Mud	0	Press Drop, DP	0							
ppb	0.00	Barite	0	Press Drop, BIT	0							
ASG		Chemicals	0	Press Drop, AMN	0							
Drill Cuttings	0	LOSSES	bbl	Actual Circ. Press	0							
Dilution Rate	0.00	Dumped	0	AV, DP	ft/min	0						
Slide Control Eff	0.00	Lost	284	AV, DC	ft/min	0						
		VOL GAIN/LOSS	-284	AV, Riser	ft/min	0						

BAROID REPRESENTATIVE Tony Kowalski / Innes Macleod	OFFICE/HOME WAREHOUSE	Cheltenham, Vic Barry Beach	TELEPHONE 03 9581 7555 03 5686 1445	DAILY COST \$A	CUMULATIVE COST \$A 58625.70
--	--------------------------	--------------------------------	---	-------------------	---------------------------------

NOTE: ALL COSTS ARE REPORTED IN AUSTRALIA'S DOLLAR
The recommendations made hereon shall not be construed as authorizing the infringement of any valid patent, and are made without assumption of any liability by BAROID DRILLING FLUIDS, INC. or its agents, and are statements of opinion only.

SEDCO 702

Baleen 2

**END OF WELL
REPORT**



Cement Job Summaries

Field	: VIC/RL5	Measured Depth	: 125.7 m
Rig	: Sedco 702	Vertical Depth	: 125.7 m
Job Date	: 11/10/99	Casing Size	: 30"
Well no.	: Baleen 2	Cement Type	: Adelaide Brighton
Job Type	: Surface Casing	Cement Class	: G

Well Data :-

BHST (DegF)	BHCT (DegF)	Hole Size (inches)	Mud Type / Weight	OGOC (Metres)	OOWC (Metres)	Deviation (degs)	TOC (metres MD)
61	61	36"	Seawater				75
			Gel Sweeps				Mud line

Casing Data :-

Centralisers (programme)	No Centralisers
Shoe Size / Arrangement	20" Shoe, 20" x 30" Crossover, 30" 235 ppf casing
Perforations	N/A

Cement Data :-

Stage	Water / Density (ppg)	Additives (Gals/10bbls) or (Gals/sx)		Thick. time (hrs:mins) BHCT time	Fluid Loss (@BHCT) (cc/30mins)	Free Water (%)	Compressive strength (psi @ Time)	Rheologies (F) 3 / 6 , 100 / 200, 300 / 600 RPM	
Single	Drill	1	Calcium Chloride	2:28	NR	0.16	50 @ 4:55		
	15.8	0.5	NF-5				500 @ 10:43		
							1444 @ 24 hrs		

Cement Job :-

Pre job	Casing Move't Circulation	Reciprocate casing during circulation and cement job Circulate hole clean with Seawater / Gel sweeps prior to cement job
Cement Job	Flush / Spacer Cement Displacement	80 bbl Sea water, 20 bbl Fresh water, Bottom Plug 108 bbl (522 sx) 'G', Drop Top Plug Displace with 313 bbl mud
Post job	Plug Pressure test	Bump plug with 2000 psi, Bled back 2.5 bbl. Floats held. N/A

Cement Logs :-

CBL-USIT not run.
CBL :
USIT :

Job Comments : Top of cement tagged at 120m.

Cement Job Summaries

Field	: VIC/RL5	Measured Depth	: 646.4 m
Rig	: Sedco 702	Vertical Depth	: 646.4 m
Job Date	: 13/10/99	Casing Size	: 9-5/8"
Well no.	: Baleen 2	Cement Type	: Adelaide Brighton
Job Type	: Intermediate Casing	Cement Class	:G

Well Data :-

BHST (DegF)	BHCT (DegF)	Hole Size (inches)	Mud Type / Weight	OGOC (Metres)	OOWC (Metres)	Deviation (degs)	TOC (metres MD)
105	92	12-1/4 "	Seawater				75
			Gel Sweeps				Mud line

Casing Data :-

Centralisers (programme)	1 st , 2 nd , 3 rd , center joint on stop collars, 4 next 4 collars, next 4 over next casing collars.
Shoe Size / Arrangement	Float shoe, 1 jt 9-5/8 " 47 ppf casing, float collar
Perforations	N/A

Cement Data :-

Stage	Water / Density (ppg)	Additives (Gals/10bbbls) or (Gals/sx)	Thick. time (hrs:mins) BHCT time	Fluid Loss (@BHCT) (cc/30mins)	Free Water (%)	Compressive strength (psi @ Time)	Rheologies (F) 3 / 6 , 100 / 200, 300 / 600 RPM	
Lead	Drill	14.6	Econolite	5:02	NR	0.8	50 @ 6:14	92 F
		12.5	NF-5				500 @ 18:30	31 / 23
							632 @ 24 hrs	20 / 17
								11 / 8
Tail	Sea	0.5	NF-5	2:38	NR	0.56	50 @ 3:40	92 F
		15.9					500 @ 7:10	177/141
							2751 @24 hrs	119/97
								33 / 22

Cement Job :-

Pre job	Casing Move't Circulation	No movement during job. Circulate hole clean with Seawater prior to cement job
Cement Job	Flush / Spacer Cement Displacement	Bottom Plug, 20 bbl Fresh water spacer 188 bbl (479 sx) Lead, 47 bbl (227 sx) Tail Drop Top Plug Displace with 130.3 bbl seawater (128.5 bbl theoretical)
Post job	Plug Pressure test	Plug did not bump. 375 psi backpressure N/A

Cement Logs :-

CBL-USIT not run.
CBL :
USIT :

Job Comments : Cement was tagged 26 m high (~6.25 bbl under displaced).

HALLIBURTON CEMENTING LABORATORY REPORT

CUSTOMER: Cultus

CUSTOMER REP:

REPORT NO: R179/S#702/B#2LOCATION: Sedco 702LAB TECH: Claudio DiazWELL NAME: Baleen 2JOB DESC: 9 5/8" – TailDATE: 7 October 1999

TEST NUMBER:	**One	Two	Three	Four
Well Data				
Depth (ft/m)	2133ft / 650m			
BHST (F)	105F			
BHCT (F)	92F			
Static Pressure (psi)	1247			
Squeeze Pressure (psi)	-			
Mud Weight (lb/gal)	8.55			
Slurry Data				
Cement Type	G			
Mixing Water	Sea			
Density (lb/gal)	15.9			
Water Requirement (gal/sk)	5.15			
Fluid Requirement (gal/sk)	5.15			
Yield (cuft/sk)	1.16			
Cement Additives				
HALAD 413L (gal/10bbl)				
SCR-100L (gal/10bbl)				
HALAD 322LXP (gal/10bbl)				
GasCon-469 (gal/10bbl)				
HR – 6L (gal/10bbl)				
PHG (%) (BWOW)				
CaCl ₂ (%) (BWOC)				
Econolite L (gal/10bbl)				
NF - 5 (gal/10bbl)	0.5			
Test Results				
Thickening time (hr : min)	2:38			
API Free Water (%)	0.56			
API Fluid Loss (cc / 30min)	NR			
Comp Strength (psi @ hrs)	2751 psi @ 24 hrs			
Fluid Rheologies				
Temperature (F)	92F			
600 rpm	177			
300 rpm	141			
200 rpm	119			
100 rpm	97			
006 rpm	33			
003 rpm	22			

NOTICE This report was prepared by and is the property of Halliburton. The data reported, intended for the private information of the above party, is limited to the sample(s) described, accordingly, any user of this report agrees that Halliburton shall not be liable for any loss or damage, regardless of cause, including any act or omission of Halliburton, resulting from the use of the data reported herein, and Halliburton makes no warranties expressed or implied, whether of fitness for a particular purpose, merchantability or otherwise as to the accuracy of the data reported.

** Recommended Slurry



PROJECT NO.: R179 #4702/Baleen #2
 DATE: 7.10.99
 PRESSURE: @ 1400 PSI
 TEMPERATURE: @ 92°F

958" - TAIL
 ULTRASONIC
 CEMENT ANALYZER
 HALLIBURTON SERVICES

INITIAL SET: 50 @ 3:40
 STRENGTH 1: 500 @ ~~8:59~~
 STRENGTH 2: 19999
 CURR. STR.: 2751 @ 23:59

COMPRESSIVE STRENGTH (psi)

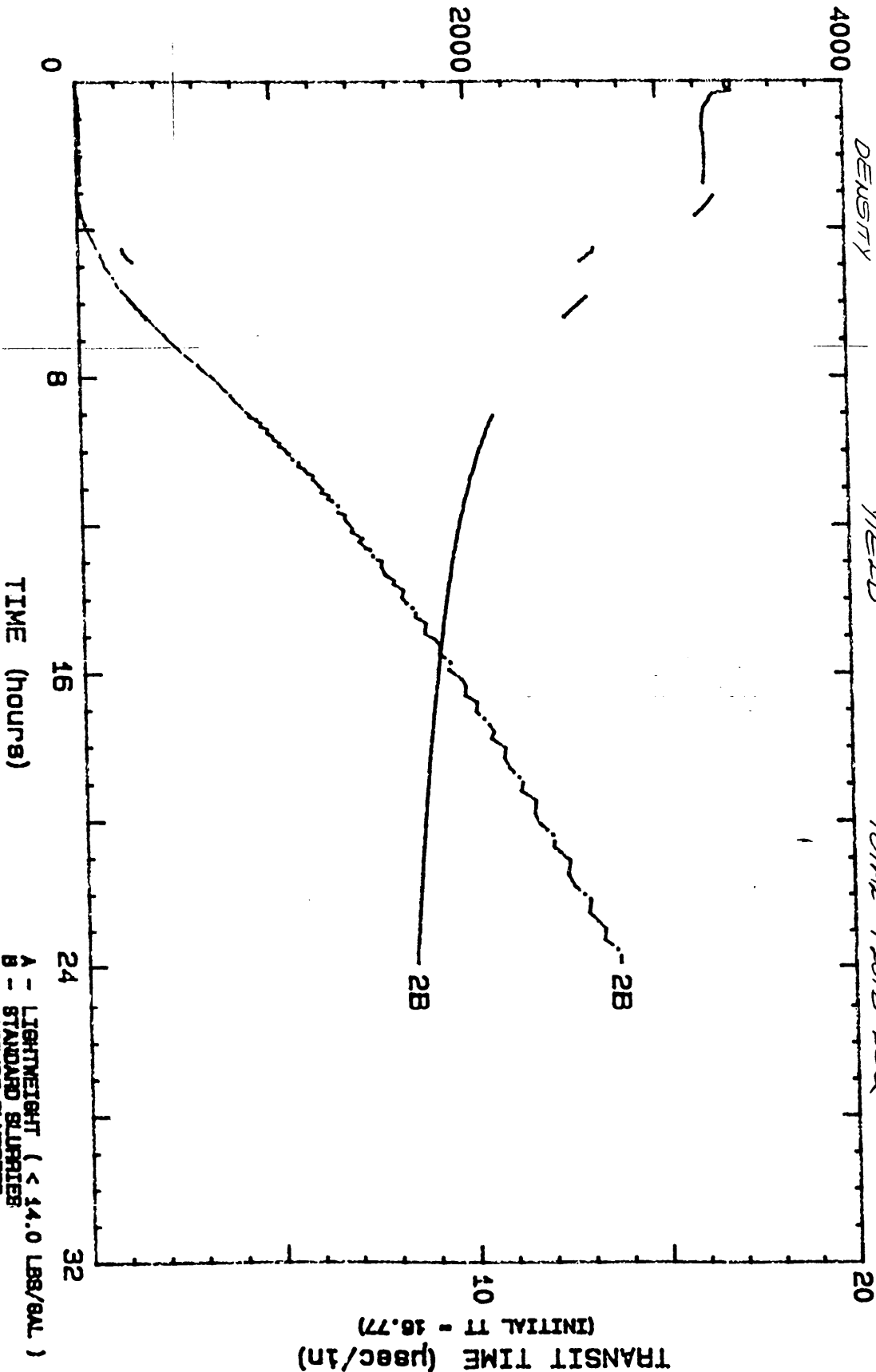

A - LIGHTWEIGHT (< 14.0 LBS/GAL)
 B - STANDARD SLURRIES
 C - DENSE SLURRIES

HALLIBURTON CEMENTING LABORATORY REPORT

CUSTOMER: Cultus

CUSTOMER REP:

REPORT NO: R178/S#702/B#2LOCATION: Sedco 702LAB TECH: Claudio DiazWELL NAME: Baleen 2JOB DESC: 9 5/8" – LeadDATE: 7 October 1999

TEST NUMBER:	**One	Two	Three	Four
Well Data				
Depth (ft/m)	2133ft / 650m			
BHST (F)	105F			
BHCT (F)	92F			
Static Pressure (psi)	1247			
Squeeze Pressure (psi)	-			
Mud Weight (lb/gal)	8.55			
Slurry Data				
Cement Type	G			
Mixing Water	Sea			
Density (lb/gal)	12.5			
Water Requirement (gal/sk)	12.54			
Fluid Requirement (gal/sk)	12.99			
Yield (cuft/sk)	2.21			
Cement Additives				
HALAD 413L (gal/10bbl)				
SCR-100L (gal/10bbl)				
HALAD 322LXP (gal/10bbl)				
GasCon-469 (gal/10bbl)				
HR – 6L (gal/10bbl)				
PHG (%) (BWOW)				
CaCl ₂ (%) (BWOC)				
Econolite L (gal/10bbl)	14.6			
NF - 5 (gal/10bbl)	0.5			
Test Results				
Thickening time (hr : min)	5:02			
API Free Water (%)	0.8			
API Fluid Loss (cc / 30min)	NR			
Comp Strength (psi @ hrs)	632 psi @ 24 hrs			
Fluid Rheologies				
Temperature (F)	92F			
600 rpm	31			
300 rpm	23			
200 rpm	20			
100 rpm	17			
006 rpm	11			
003 rpm	8			

NOTICE This report was prepared by and is the property of Halliburton. The data reported, intended for the private information of the above party, is limited to the sample(s) described, accordingly, any user of this report agrees that Halliburton shall not be liable for any loss or damage, regardless of cause, including any act or omission of Halliburton, resulting from the use of the data reported herein, and Halliburton makes no warranties expressed or implied, whether of fitness for a particular purpose, merchantability or otherwise as to the accuracy of the data reported.

** Recommended Slurry



PROJECT NO.: R178/SH 702/Baleen #2
 DATE: 7.10.99
 PRESSURE: @ 1200 PSI
 TEMPERATURE: @ 92 F

(9387-LEAD)
 ULTRASONIC
 CEMENT ANALYZER
 HALLIBURTON SERVICES

INITIAL SET: 50 @ 6:14
 STRENGTH 1: 500 @ 18:30
 STRENGTH 2: 19999
 CURR. STR.: 632 @ 24:19

CEMENT: ABC 15" 14.6 gal/100lb ECOROLITE L SEAMASTER
12.5 lb/gal 2.21 ft³/sk 12.54 gal/sk 12.99 gal/sk
 DENSITY 11.0 11.0 11.0 11.0
 YIELD 5.71 5.71 5.71 5.71
 TOTAL FLUID REQ.

COMPRESSIVE STRENGTH (psi)

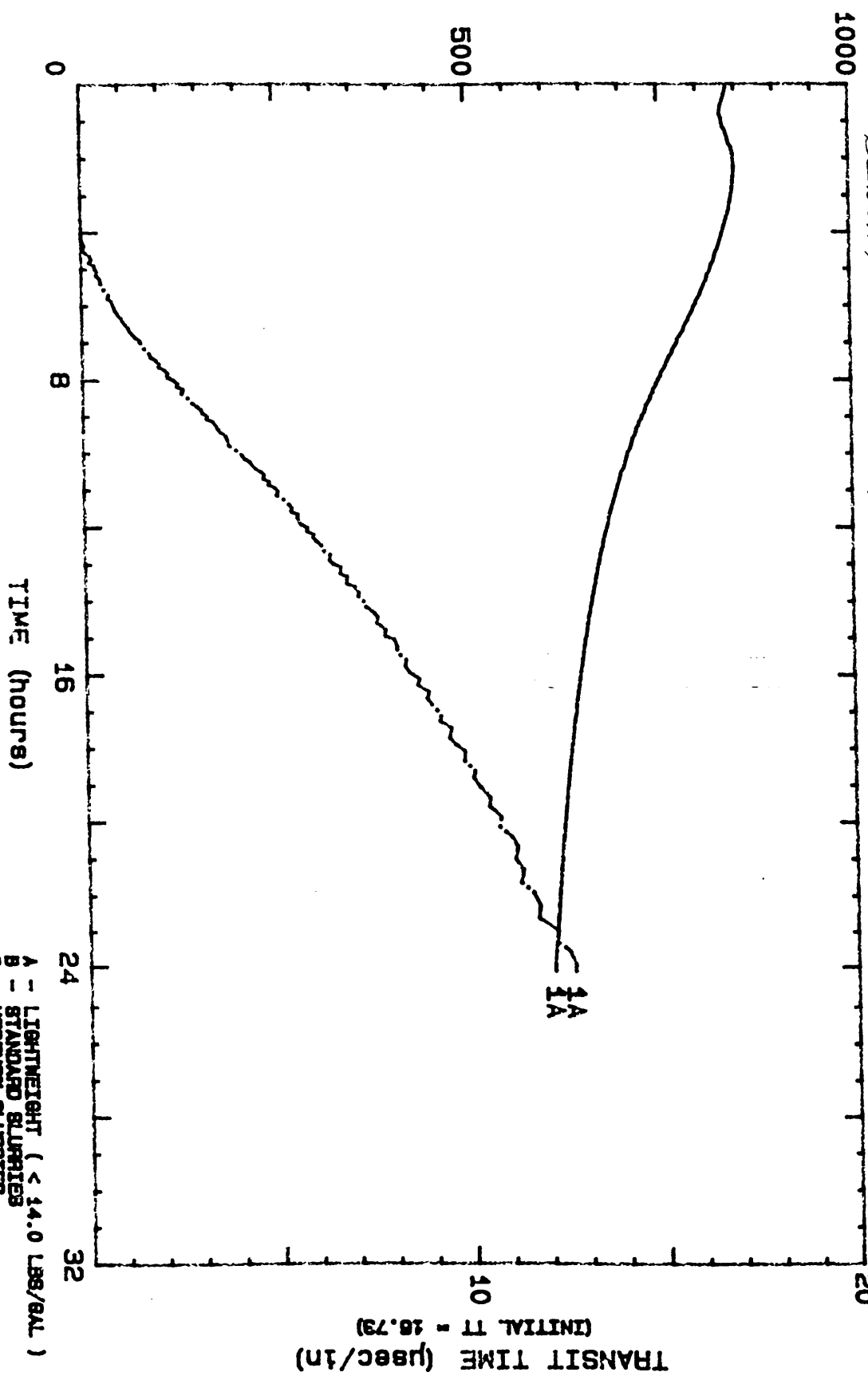

A - LIGHTWEIGHT (< 14.0 LBS/GAL)
 B - STANDARD SLURRIES
 C - DENSE SLURRIES

HALLIBURTON CEMENTING LABORATORY REPORT

CUSTOMER: Cultus

CUSTOMER REP:

REPORT NO: R177/S#702/B#2LOCATION: Sedco 702LAB TECH: Claudio DiazWELL NAME: Baleen 2JOB DESC: 30"DATE: 5 October 1999

TEST NUMBER:	**One	Two	Three	Four
Well Data				
Depth (ft/m)	410ft / 125m			
BHST (F)	61F			
BHCT (F)	80F			
Static Pressure (psi)	432			
Squeeze Pressure (psi)	-			
Mud Weight (lb/gal)	8.55			
Slurry Data				
Cement Type	G			
Mixing Water	Sea			
Density (lb/gal)	15.9			
Water Requirement (gal/sk)	5.15			
Fluid Requirement (gal/sk)	5.15			
Yield (cuft/sk)	1.16			
Cement Additives				
HALAD 413L (gal/10bbl)				
SCR-100L (gal/10bbl)				
HALAD 322LXP (gal/10bbl)				
GasCon-469 (gal/10bbl)				
HR - 6L (gal/10bbl)				
PHG (%) (BWOW)				
CaCl ₂ (%) (BWOC)	1			
Econolite L (gal/10bbl)				
NF - 5 (gal/10bbl)	0.5			
Test Results				
Thickening time (hr : min)	2:28			
API Free Water (%)	0.16			
API Fluid Loss (cc / 30min)	NR			
Comp Strength (psi @ hrs)	1444 psi @ 24 hrs			
Fluid Rheologies				
Temperature (F)	NR			
600 rpm				
300 rpm				
200 rpm				
100 rpm				
006 rpm				
003 rpm				

NOTICE This report was prepared by and is the property of Halliburton. The data reported, intended for the private information of the above party, is limited to the sample(s) described, accordingly, any user of this report agrees that Halliburton shall not be liable for any loss or damage, regardless of cause, including any act or omission of Halliburton, resulting from the use of the data reported herein, and Halliburton makes no warranties expressed or implied, whether of fitness for a particular purpose, merchantability or otherwise as to the accuracy of the data reported.

** Recommended Slurry



PROJECT NO.: R17 / S# #02 / B#2
 DATE: 5.10.99
 PRESSURE: @ 400 PSI
 TEMPERATURE: @ Room TEMP.

(301)
 ULTRASONIC
 CEMENT ANALYZER
 HALLIBURTON SERVICES

INITIAL SET: 50 @ 4:55
 STRENGTH 1: 500 @ 10:43
 STRENGTH 2: 19999
 CURR. STR.: 1444 @ 23:59

CEMENT: ABC 11.5" cur + 1% (Bmc) Cccl₂ + 5.15 gal/sk + 5.15 gal/sk
15.9 lb/gal + 1.15 fe₃/sk + S.M. RES
 DENSITY YIELD TOTAL FLUID RES

COMPRESSIVE STRENGTH (psi)

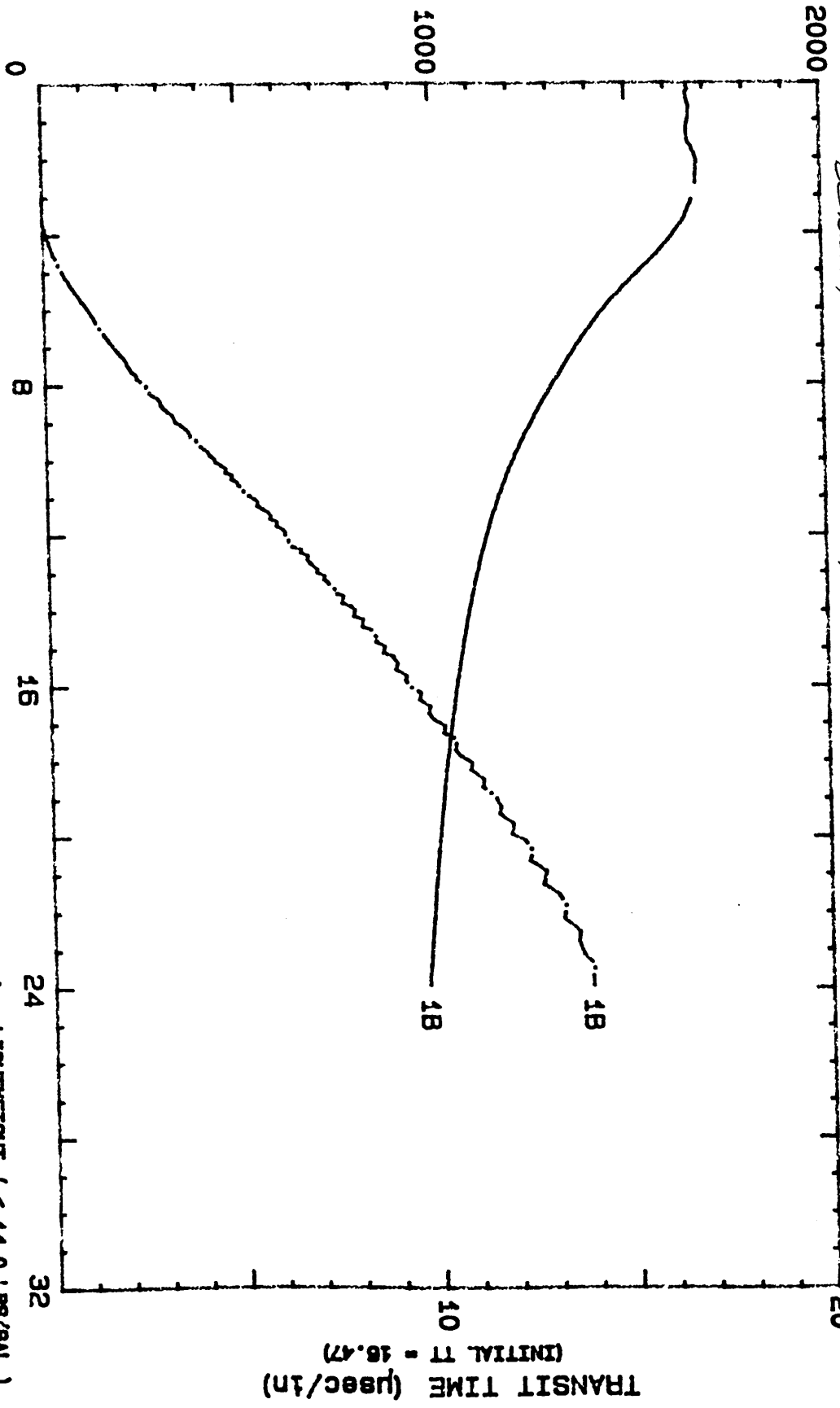

A - LIGHTWEIGHT (< 14.0 LBS/GAL)
 B - STANDARD SLURRIES
 C - HEAVY SLURRIES

Cultus Petroleum
 Basin Oil NL
 Baleen 2
 October 1999



BHA Summary Table

BHA #1	BHA #2	BHA #3	BHA #4	BHA #5	BHA #6
Drill Tophole Seabed - 126m WOB: 5 MT RPM: 70 Pump Rate: 1000 gpm	Drill out Shoe track	Drill 12 1/4" Hole 126 - 650m WOB: 10 MT RPM: 130 Pump Rate: 1030 gpm	Drill to Coring Point 650m - 746m WOB: 10 - 15 MT RPM: 70 - 110 Pump Rate: 634 gpm	Core Guard Formation 746 - 780m (2 runs) WOB: 5 MT RPM: 70 Pump Rate: 190 gpm	Drill to TD 780 - 895m WOB: 15-20 MT RPM: 90 Pump Rate: 450 gpm
26" Y11 Bit (111 w/ 3x 24 nozzles) Crossover 36" DSJ Custom 4 H/O (111 w/ 3x 20 nozzles) Float Sub 3x 9 1/2" Drill Collars Crossover 3x 8 1/4" Drill Collars Crossover 15x 5" HWDP	17 1/2" MSDSSHOC Bit (137 w/ 3x 24 nozzles) Float Sub 9x 8 1/4" Drill Collars Crossover 15x 5" HWDP	12 1/4" DS40H PDC bit 12 1/4" NB Stab Crossover 8" Anderdrift 12 1/4" String Stab 8" NMDC 12 1/4" String Stab 10x 8 1/4" Drill Collar Crossover 15x 5" HWDP	8 1/2" MHT13G bit (137 w/ 3 x 18 nozzles) Bit Sub 2 x 6 1/4" Drill Collars Crossover 4" IF x 4 1/2" IF 8 1/2" String Stab Crossover 4 1/2" IF x 4" IF 10 x 6 1/4" Drill Collars Crossover 4" IF x 4 1/2" IF 6 1/4" Jars (Dailey) Crossover 4 1/2" IF x 4" IF 3 x 6 1/4" Drill Collars Crossover 4 1/2" IF x 4" IF 15x 5" HWDP	CD73 Corehead 8 15/32 Stab 8m Core Barrel 8 15/32 Stab 8m Core Barrel 8 15/32 Stab Crossover to 4 1/2" IF Safety Joint Crossover 4 1/2" IF x 4" IF 9 x 6 1/4" Drill Collars Crossover 4" IF x 4 1/2" IF 6 1/4" Jars (Dailey) Crossover 4 1/2" IF x 4" IF 3 x 6 1/4" Drill Collars Circulating Sub Crossover 4 1/2" IF x 4" IF 1x 5" HWDP Dart Sub 14x 5" HWDP	8 1/2" EHP43ADH (437 w/ 3x 14 nozzles) 8 1/2" NB Stab 4.5m Pony NMDC 8 1/2" String Stab NMDC 8 1/2" String Stab Crossover 4 1/2" IF x 4" IF 9 x 6 1/4" Drill Collars Crossover 4" IF x 4 1/2" IF 6 1/4" Jars (Dailey) Crossover 4 1/2" IF x 4" IF 3 x 6 1/4" Drill Collars Crossover 4 1/2" IF x 4" IF 15x 5" HWDP



INTEROFFICE MEMORANDUM

DATE: 28 Oct '99
TO: Chris Way
FROM: Willem Boon
SUBJECT: Baleen #2 Drilling Operations – Lessons Learnt

Wellhead

20" shoe below the 30 conductor was drilled out with separate 17 1/2" bit and BHA. As the 30" can not be swedge down to 13 3/8" directly the use of a second crossover from 20" to 13 3/8" could be considered.

The 20" extension below the 18 3/4" housing comprised a welded swage to the 9 5/8" casing. For the development well the 20" x 9 5/8" crossover swedge should be supplied as a separate item with a 1/4 turn or stabbed connector to ensure safe handling of the wellhead. However, the connection will need to be gas tight as it will be an integral part of the 9 5/8" production casing.

Casing

The 9 5/8" casing was set at 650m RT approx. 96m above the top reservoir. With improved confidence of picking the top reservoir at the development well location the 12 1/4" hole section can and should be drilled to 50m or less above the top reservoir. This will allow permanent downhole gauges (if required) to be installed closer to the top reservoir.

Mud

NaCl salt was used instead of KCl to inhibit the claystone without compromising the log and core analysis. For the development wells the mud system should be reverted to KCl.

The use of bulker bins for the salt improved the offshore handling of the salt and reduced the number of containers required for shipment. Due to the lack of container the contingency salt was also loaded out in the bins and the excess salt had to be disposed off offshore at the end of the well. For the development wells excess salt should be shipped in big bags and containers.

The supply of bulk bentonite from Geelong and Welshpool involved transfers from multiple truck loads direct to the boats. Access to bulk facilities for bentonite would significantly improve the supply of bentonite to the rig. As a contingency guar gum or an equivalent gel that can be mixed with seawater should be mobilised.

Cement

Returns were observed during cementing of 30" casing. There were no clear indication when retrieving the 30" housing during the abandonment that the casing was cemented to surface. For the development wells confirmation will be required to cement the conductor to surface to support the axial and lateral loads generated by the subsea tree and flowlines.

As the 9 5/8" casing is run below the 18 3/4" wellhead a top up job of the 20" x 9 5/8" with the current set up is not possible in order to improve the structural integrity of the housing and wellhead system.

Drilling

The make up of the tophole and 12 1/4" BHA and the 30" housing and wellhead with running tools during the rig move remove the handling and preparation of these larger pieces of equipment of the critical path. This saved approx. 24 hrs rig time of the planned time estimate at the start of the programme.

A PDC bit (DS40) successfully drilled the 12 1/4" hole section. With controlled parameters drilled the section riserless the bit still achieved an average of 126 m/hr and the bit was pulled with a 1-1 bit grading.

8 1/2" hole section was drilled in two section. A rock bit (MHT13) was used to drill to the coring point at controlled. An insert bit (EHP43) was used to drill the section to TD. The ROP performance was reasonable. Review of the mud log and electric log data should be review to establish whether PDC can be utilised for the development wells. As no coring is planned for the development wells it is reservoir section should be drilled in one bit run with improved ROP.

Logging

Gas sampling was not achieved from the Gurnard formation. During MDT run #1 the pad seal was continually lost, possible as a result of a combination of high draw down and friable reservoir sands. For MDT run #3 and #4 a standard probe was used, but on both occasion the tool was flooded with sand.

The MDT logs should be reviewed to establish to what drawdown the reservoir sands were exposed to during the sampling.

Also, during project FEED the acquired log data should be utilised for RMA (Rock Mechanical Algorithm) analysis. The analysis will qualify the stability and sanding potential of the Gurnard reservoir sands.

Logistics

The two logistics supervisors played an important part in the success of the Baleen 2 drilling operations.

Baleen -2 Well

1. **Reporting systems:** ensure all office and field computers and printers have been checked out and a sample report generated on a reliable phone system similar to the one to be used offshore. They should be upgraded to include windows 98. Ensure there is a reliable email provider in place and a similar system in place for the well site geologist. Do not use the westing house 100 system.
2. **Office pack:** prepare an office pack and send out early along with all manuals, time permitting, a list to be generated.
3. **Surface Hole:** Use a pony dc between bit and hole opener when using the 20/30" shoe combination. This gives more support at the bottom and requires less cement when 200% excess is required.
4. **Conductor:** Use a 3 rather than 4 joints of 30" conductor if possible unless a valid reason for 4.
5. **Hi Vis sweeps:** surface hole, plan to have at least 50 sacks of guar gum on site for use as hi vis pills rather than all gel sweeps or other material that can be mixed in seawater.
6. **Cement on 30":** use 2 % cacl 2 during cementing of 30", run the stinger at least 8 m from the shoe, then displace to 3 m of the shoe.
7. **Wellhead joint to smaller size casing:** hard to handle with the left hand thread running tool installed: suggest that a squinch joint or ¼ turn connecter be used rather than a short threaded joint to enable ease of handling with the 183/4" wellhead. Also note that any spacer or crossover joint should be at least 6 m long for ease of handling with the rig equipment.
8. **Plug did not bump:** using the measured volume from the pumping unit tank, take random measurements on casing ID to assist in displacement and plug bumping during cement jobs.
9. **Long abandonment:** review all abandonment plans and PSLA on how exactly things should be done, also review rigs capability to handle tools easily. Try and have 20 joints of 31/2" dp on site with correct handling tools rather than 27/8". (this is not a requirement if in 121/4" hole size)
10. **Casing Cutting:** cutting time 3 hours and 20 minutes and cut on an angle as a mule shoe: suggest that some sort of stabiliser be used to centre the 20" casing inside the 30" to assist in the cutting on abandonment.
11. **Incidents:** review vessels handling gear prior to rig move: see incident report from the Pacific Challenger.
12. **Surveys:** Run the Andergauge tool each well to reduce survey times and reduce risks of stuck pipe. Verify tool strengths for position in the BHA to be most effective and still allow MSS to be run.
13. **Mud:** Have the mud supply company supply 4mt bulk bins for salt or KCL, this reduces loss, is safer and reduces handling of the big bags.
NOTE: Bulk handling of mud and cement with trucks results in a 15% loss of material.
rjk

908058 216

INTEROFFICE MEMORANDUM

To: Chris Way,

Cc: Willem Boon, Ray Kohut, Mark Adamson

From: Gordon Nicholl

File : Cultus IOM 005 Baleen 2 Lessons Learned 22 October 1999

RE: Baleen #2 Drilling Operations – Comments

The following comments are based on observations from the Baleen #2 operation. Several of these observations crop up due to the short duration of the planning phase and limited time available for equipment mobilization. This note includes points raised by Ray and Wally from the rig end.

1. DQ Wellhead Equipment

- The 30" string was run with four joints below the seabed. Seabed conditions were not known at time of planning. The seabed appeared to have good integrity and reducing this to three joints should be considered in future wells.
- The 30" was swaged to a 20" shoe joint (8m). It has been suggested that the 26" bit be run on a pony DC below the 36" hole opener to provide a 26" pocket for the full length of the 20" shoe joint. This would reduce the cement volumes and provide a more stable base than 20" in 36". Ledging did not appear to be a problem.
- Cement was 1% CaCl₂ in SW. Running 2% CaCl₂ could be considered. Cement was slow to reach good compressive strength resulting in lost rig time.
- 18-3/4" Wellhead housing was supplied with a 20" 1" wt. extension joint below the wellhead and above the swage to 9-5/8". The base of the 20" joint should have four short centralization fins installed to centralize the 20" in the 30" while cutting. These need to be positioned low to be clear of the cutting tool.
- Installation of the RT/WH/Extension Joint/Swage to the 9-5/8" surface string needs to be further evaluated. Weight of the assembly and RH make up of the casing cross over make this operation prone to galling in the top casing connection. One option is to cross over up to 20" and use a 1/4 turn connector or squench connector although additional rig up would be required to M/U a 20" 1/4 turn connector. Exact M/U procedure from last casing joint to running string on DP needs evaluation to determine the best option.

10/27/99 9:37 AM

1 of 5

own

303058 217

2. Bulk Materials Loadout

The bulk loadout was done from Geelong onto the Pacific Challenger using Toll Energy Logistics. The bentonite loaded was based on 30 ppb gel on sweeps and using the base 10 ppg mud pre-mixed for the 8-1/2" hole section as a kill mud if required. The contingency was reduced on this basis and attempts were made to source guar as a viscosifier to supplement PHB.

Due to the logistics involved in replacing the NaCl/PHPA/PAC mud for the 8-1/2" hole section if it was used as a shallow gas kill mud the decision was made to prepare a bentonite/barite kill mud. Coupled with reduced bentonite due to transfer losses, the bentonite supply was marginal.

Suggest that given time guar gum be mobilized and/or additional bentonite be loaded out. An additional 660 sks, 30MT was loaded from the Welshpool but was not required.

Barite was not loaded out based on the rig inventory. The rig inventory was found to be in error by ~ 900 sks, 41 MT after the Statement of Facts. An additional 30MT was loaded out of Welshpool on boat #3.

- Confirmation of the bulks on handover is required using both P tank weight and physical sounding as was done in this case. On short wells with longs logistics lead time for bulk this is very important. Early confirmation is required.

Salt Bins

The drilling fluids contractor has 6 MT bulk bins that load out up to 5.5 MT of product. These were used and loaded with 4 MT NaCl due to possible handling restrictions at Welshpool jetty.

- Load out primary product required in bins plus 30% contingency. Load out any additional product in 1.5MT bags in baskets. Excess salt (20 MT) loaded out in bins was dumped as it could not be restocked and the next operator required KCl.

3. Rig Move Draft

The move was done at 80 – 85 ft drilling draft. Tow speed was 2.5kn average. Weather was good throughout move. Fuel consumption was 27.5 m3 per vessel, 12,000 BHP, 110MT. Tow length was 195 miles or 78 hrs.

- Towing at this draft allowed preparations for drilling to continue. BHA's and spud mud was mixed on tow, drill pipe was left in the derrick, all well equipment and casing was onboard for move. The 30" string was picked up and hung off in moon pool while finalizing anchor operations.
- Anchoring at deep draft has the anchors run below sea-level. Three anchors were re-run after failing to set and one chaser pendent was damaged. This may have been due to the anchor being fouled off the bolster as visual observation is not possible.

903058 218

- The incident investigation on the Pacific Challenger raised the point that picking up the tow bridle at deep draft placed the AHSV close to rig cross members when picking up the bridle and that the tow bridle was too short. This may or may not have been a contributing factor to the incident but does highlight the need to ensure that the rig to vessel communication in pre-move planning is effective.
 - The two work boats from Swire Pacific were both using different methods and equipment to handle the tow bridles, one resulting in a Near Miss incident. Further investigation is on going. One recommendation from the operator side is to get complete deck inventories when signing up the Charter Party. This will facilitate better information between various contractors.
4. The 12-1/4" surface hole section was drilled with an 8" Anderdrift tool. This tool worked well and based on the number of surveys required between 125 and 650mRT was good value compared to Totco surveys. Inclination was under 1/2° and was backed up with a magnetic single shot at casing point. No further surveys were taken. The Dipmeter data was used in the 8-1/2" hole section.
 5. The DS40 PDC bit averaged 46 m/hr including connections. The 12-1/4" hole section was drilled riserless and ROP was achieved with minimal weight on bit. Higher ROP's were possible but given the lack of riser in the top section and limited gel on board if hole cleaning became an issue, WOB and ROP was held back.
 6. 9-5/8" casing was run without difficulty. Wellhead weight on the 9-5/8" LTC connection was noted above. The SSR plug was noted to release after the DP dart landed but was 6 bbl out on displacement at 650mRT. Differential pressure was 375psi indicating good cement top and the plug was not bumped. Casing ID should be caliper checked to determine the average ID and this ID considered in displacement calculations. In long TVD jobs balloon effects due to displacement pressure should also be considered.
 7. BOP connector and fail safe tests were done against a test plug. The casing was then tested before drilling the shoe track out. The leakoff test was taken to 1.8 SG FIT. The integrity of all casing strings set into the Lower Gippsland/Upper Lakes Entrance and been good in all Patricia/Baleen wells to date. Kick tolerance is therefore not considered an issue below the 9-5/8".
 8. No hole problems were noted in the Lake Entrance above the Gurnard Fm although the Lake Entrance was possibly eroded at this location more than normal. Pushing the 9-5/8" casing point closer to the Gurnard Fm does not achieve any advantage and increases risk of encountering the Gurnard gas column without primary or secondary well control. The reservoir pressure is higher than seawater and the section is drilled without riser. A move off drill was run and 10.5 ppg kill mud was available. The casing point was 55 to 85m above the Gurnard based on the offset data which placed the Top Gurnard at -30/Prognosis/+10m TVD.

903058 219

9. The 8-1/2" hole section was control drilled from 650 to 746mRT looking for core point. The Depth vs Days curve shows that the time spent looking for the core point was nearly breakeven to drilling slightly above the most probable core point and coring on depth. The 1-3-5 MT bit did not drill as fast as a PDC. There was discussion that the pyrite bed in the base of the Gurnard could scrub a PDC bit although the offset wells were drilled with older generation tooth bits through this section and did not suffer excessive wear. Drilling this section to TD with a fairly heavy set PDC would achieve higher ROP in the Lake Entrance mudstone.
10. Coring was with a CD73 face discharge bit into aluminum sleeves. Flow rates were low at 175 gpm but core ROP was high. Core #1 jammed after 17m with 100% recovery, speculated to have jammed on interface to a siderite band. The second core cut 18.5m with 88.5% recovery. Gurnard Fm was shown to be weak, based on formation collapse on MDT sample attempts.
11. The well was drilled to TD with a TCI bit at reasonable ROP but again future development wells should consider PDC usage from the shoe to TD if intermediate core evaluation is not planned.
12. Hole caliper was generally good with filter cake build up over permeable zones. API FL was 4 cc, HTHP was 16 cc. Overbalance was 203 psi at 746mRT based on 10.1 ppg mud and 1080 psi reservoir pressure. Planning was done on 1090 psi at 705mRT, the upper prognosed top or 124 psi. Further reduction in mud weight is not recommended based on the shallow depth and possible H₂S content.
13. NaCl was used rather than KCl. This was done for the NGT/GR. If formation evaluation is not including core and NGT logging use of KCl is recommended.
14. The MDT programme included a multi-sampler tool. Samples were not successful. Problems occurred with breakdown of the formation around the seal. A report on the MDT was requested from Schlumberger.
 - Need to review the MDT pressure response and drawdown placed on the formation while sampling and while pre-testing.
 - The first probe was a large diameter screened "snorkel" inside a large diameter pad. Sand production was not reported although the seal was continually lost.
 - The second run used a conventional probe and sand was pumped up through the tool and into the buffer chamber. The same result occurred on run #3. Apparently sampling pressures were problematic but successful. Moving fluids with higher drawdown induced sand failure.
 - Was the high drawdown a function of fluid blockage and possible clay swelling in the pores that may be assisted by K ion in mud? Was the drawdown excessive and if so was it different to the pressure survey points? Would a lower volume MDT pump be worthwhile? Was the reservoir immediately exposed to the atmospheric pressure of the buffer chamber in the Multisampler Up/Dwn pump configuration

903058 220

rather than the In/Out configuration of the OFA/MDT where discharge is to the annulus at hydrostatic pressure? Hopefully the Schlumberger report will touch on some of these issues.

15. The Logistics personnel were excellent and the success short duration of this project was partially due to using a team of personnel who had previously worked together.

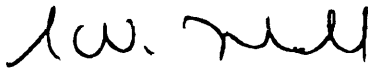

Gordon Nicholl
Drilling Superintendent

Cultus IOM 005 Baleen 2 Lessons Learned 22 October 1999

908058 222

903058 223

HYDROGRAPHIC SURVEYS PTY. LTD.

SERVICES IN THE OCEAN SCIENCES

A.C.N. 001 325 186

ENGINEERING-HYDROGRAPHIC-OCEANOGRAPHIC-ENVIRONMENTAL-GEOPHYSICAL INVESTIGATIONS



21 LYNWOOD STREET, BLAKEHURST, NSW, 2221, AUSTRALIA

TEL: +61 2 95467536

FX: +61 2 95464768

MOBILE: 0412113921

MOBILE FAX: 0412216607

E-MAIL: syzygy@zip.com.au

**VICTORIA
RIGMOVE OF THE DRILLING
RIG SEDCO 702
BALEEN #2
Vic/RL5
for
CULTUS PETROLEUM**

**REPORT H540R1
OCTOBER 1999**

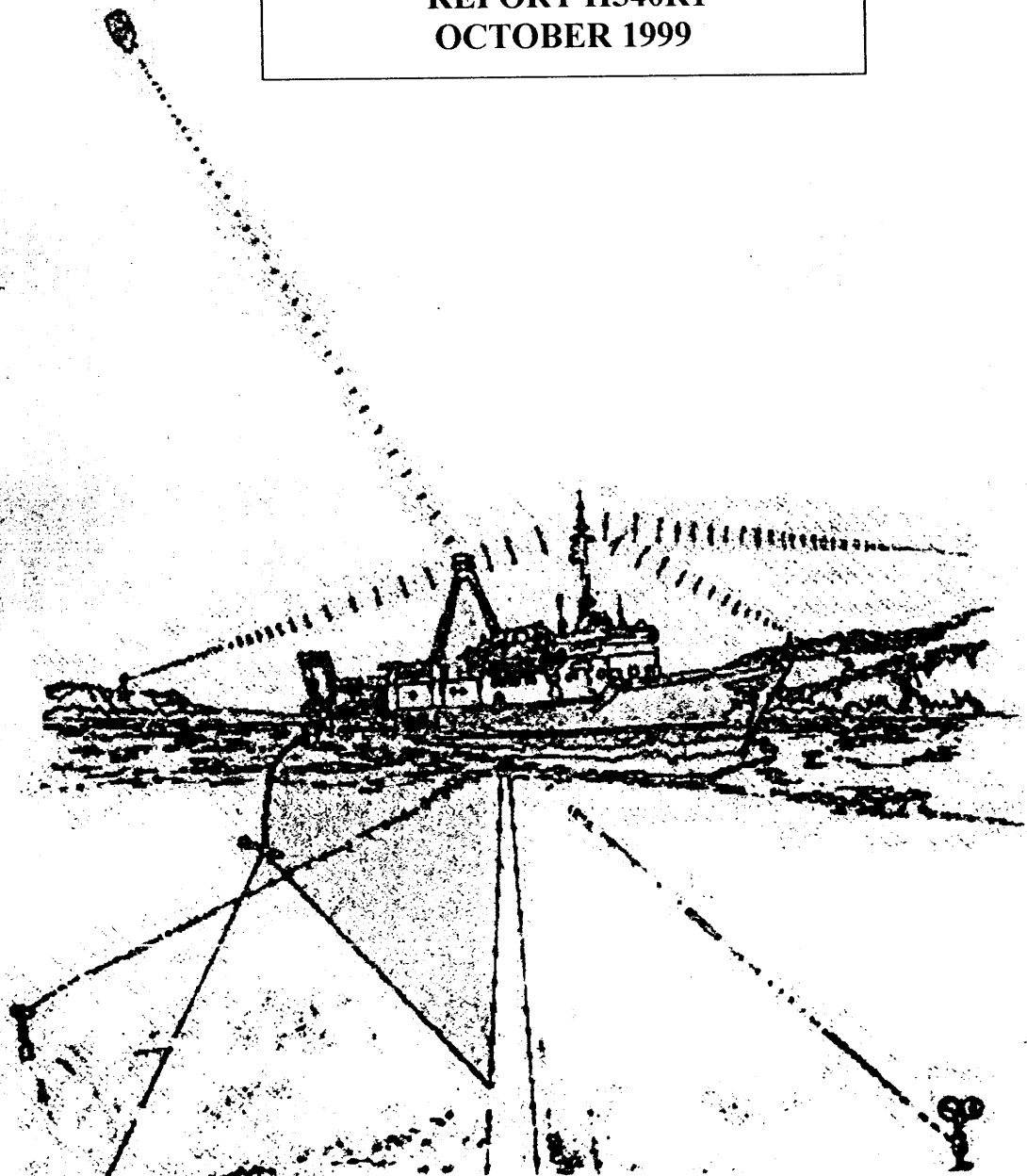

VICTORIA
RIGMOVE OF THE DRILLING RIG
SEDCO 702
TO
BALEEN #2
Vic/RL5
FOR
CULTUS PETROLEUM
REPORT H540R1
OCTOBER 1999

HYDROGRAPHIC SURVEYS PTY. LTD.
21 Lynwood Street, BLAKEHURST, NSW, 2221.
Ph: 61-2-95467536 Fx: 61-2-95464768
Mob: 0412113921 e-Mail: syzygy@zip.com.au

Contents

1.0 INTRODUCTION	3
2.0 PROJECT SUMMARY	3
2.1 COORDINATE SYSTEM	4
2.2 DATUM TRANSFORMATION.....	4
2.3 WELL LOCATION INFORMATION.....	5
3.0 MOBILISATION	6
4.0 OPERATIONS	6
5.0 EQUIPMENT	7
5.1 EQUIPMENT PERFORMANCE	7
5.2 EQUIPMENT SUITABILITY	7
6.0 HEALTH SAFETY AND ENVIRONMENT.....	7
7.0 PERSONNEL PERFORMANCE.....	7
8.0 CONCLUSIONS AND RECOMMENDATIONS.....	8
9.0 TOWING VESSELS, CURRENTS, WEATHER.....	8
10.0 RACAL REPORT	8

APPENDICIES

APPENDIX A-	DAILY RECORD SHEET (RACAL SURVEY)
APPENDIX B-	GNS SYSTEM DATA PRINTOUTS (RACAL SURVEY)

1.0 INTRODUCTION

The following report details the rig move of the drilling rig "SEDCO 702" from Globex Barramundi 1 to the Baleen 2 location in permit VIC/RL5, Bass Strait, Victoria.

Racal Survey Australia Pty Ltd (Racal) were contracted to supply positioning services and Hydrographic Surveys Pty Ltd (HS) were contracted to provided offshore QC services for CULTUS Petroleum.

Both Racal service personnel was on board the 'SEDCO 702' from 4th October, during the move off from Globex Barramundi 1 location. HS personnel were mobilised to the rig on the morning of the 8th October, 1999, as it was enroute to location. The rig was located at the Baleen 2 location at 0135hrs on 11th October, 1999.

A final fix was observed at the Baleen 2 location on 11th October, 1999 and the survey team was demobilised from the rig the same day.

2.0 PROJECT SUMMARY

2.1 COORDINATE SYSTEM

The following coordinate system was used:

Datum:	Australian Geodetic Datum 1966
Spheroid:	Australian National
Eccentricity:	0.006694542
Semi-major Axis:	6378160.00
Projection:	Australian Map Grid
False Eastings:	500 000m
False Northings:	10 000 000m
Origin of Latitude:	0°
Central Meridian:	147° East (Zone 55)
Scale factor at CM:	0.9996

2.2 DATUM TRANSFORMATION

The following seven parameter shift was used to convert coordinates from WGS 84 to AGD 66

DX	=	+123.314m
DY	=	+47.223m
DZ	=	-136.594m
rx	=	0.264"
ry	=	0.322"
rz	=	0.270"
Scale	=	1.384 ppm

2.3 WELL LOCATION INFORMATION

Baleen-2 Final DGPS Drill Stem Position

Datum: AGD 66
Latitude: 38° 01' 55.76" South
Longitude: 148° 24' 37.55" East

AMG Zone 55 (CM 147° East)

Eastings: 623 781.41m
Northings: 5 789 663.90m

Final heading: 206.4° (true)

This final location is a distance of 1.1 m on a bearing of 326° from the proposed Baleen 2 location.

Intended Baleen 2 Location

Datum: AGD 66
 Latitude: 38° 01' 55.79" South
 Longitude: 148° 24' 37.57" East

AMG Zone 55 (CM 147° East)

Eastings: 623 782m
 Northings: 5 789 663m

Intended heading: 210° (true)

3.0 MOBILISATION

The following mobilisation and demobilisation dates apply:

CULTUS Survey Rep	Bill Edmonds	5 th October to 11 th October 1999
Racal Personnel	Chris Hakkennes	4 th October to 11 th October 1999
Racal Personnel	Troy Langley	4 th October to 11 th October 1999

Racal positioning equipment was mobilised onto the drilling rig on the 5th October, prior to leaving the Globex Barramundi 1 location. All setup parameters, coordinates and position output were checked by the HS (CULTUS) survey representative.

A gyro calibration was calculated after a sun observation at 1755hrs on 6th October 1999.

4.0 OPERATIONS

Mr.C.Hakkennes (Racal) was mobilised to Essendon on 4th October, and Mr.T.Langley (Racal) was mobilised to Essendon from Perth on the same day. Mr.W.Edmonds HS (CULTUS) survey representative was mobilised to Melbourne on the 5th October, for mobilisation on the following morning. Due to operational delays, Mr.W.Edmonds was not sent to the rig until the morning of the 8th October. Survey equipment was set-up and commissioned on the 5th October .

All calculations for the co-ordinate transformation and waypoints were completed and checked upon arrival onboard the rig by HS personnel on 8th October 1999, as the rig was enroute to the Baleen 2 location.

The rig approached the intended location on a bearing of 232° and the #7 anchor was on the bottom at 1150hrs on 10th October 1999. Positioning of the rig continued until 2320hrs on 11th October, when pre-tensioning of all anchors commenced. A final fix was observed between the hours of 0200 and 0240 on 11th October.

The survey team was demobilised from the rig on 11th October. Racal Survey equipment was boxed up and stored on the rig for the next proposed move.

5.0 EQUIPMENT

5.1 EQUIPMENT PERFORMANCE

Power loss within the bridge radio room caused minor loss of fix positions whilst the rig was enroute to location. Skyfix positioning data was also lost for a short time on the afternoon of the 10th October, this was due to Racal Singapore re-setting all receivers.

The radar on the bridge was not operable and could not be used for tracking the anchor drop positions from the rig.

No serious delays could be attributed to equipment performance .

5.2 EQUIPMENT SUITABILITY

The equipment used during this survey programme was suitable for the survey purpose.

All equipment supplied by the contractor met the required specifications.

6.0 HEALTH SAFETY AND ENVIRONMENT

The compliance with safety procedures was maintained during this survey. Personnel displayed a good attitude toward safety procedures and used the required PPE during all survey operations.

The HS survey rep and Racal personnel attended required safety meetings and drills.

7.0 PERSONNEL PERFORMANCE

Personnel worked safely and efficiently throughout this project.

8.0 CONCLUSIONS AND RECOMMENDATIONS

It is recommended that all communications related to positioning should continue to state what coordinate system or datum the coordinates refer to, e.g. WGS84, AGD66.

If possible, a site survey of the proposed drilling location should be made available.

The survey contractor demonstrated their ability to perform all necessary operations to complete the rig move in a safe and efficient manner and would be recommended for similar projects in the future.

9.0 TOWING VESSELS, CURRENTS, WEATHER

A slower than expected towing speed of 1.5 to 2.5 knots was maintained during the transit, partially due to the prevailing winds and currents. Both vessels performed well during the rigmove.

The weather remained fine and mild during the duration of the move.

10.0 RACAL REPORT

Not received at this time.

Hydrographic Surveys Pty. Ltd.



G. W. Hills

APPENDIX 1.

Date: 5/10/94 Client: CULTUS Job No.: 2930 AS Vessel: SEARCHER Location: BALEEN 2

PAGE 2 OF

Equipment	Op	
SkyFix		✓
LandStar		✓
Gyro		✓
PCGNS		✓
MultiFix II		✓
GRREP		✓
SkyTrac		

Equipment	Op	
Deso Echo Sounder		
Sidescan		
Boomer		
Heave Co.		
STD-12		
ENSIN		

Racal Personnel
T. ALLEN
Client Personnel
R. HANBY

WX	Sea State	Swell	Wind Dir.
0000			
0600			
1200			
1800			

DIARY OF OPERATIONS

TIME	Time Zone = UTC+ 10 E.S.T.
04:00	TL & LM. MEASURED OFFSETS FOR GPS ANTENNAE
05:20	#5 P.C.P. PASSED TO PACIFIC CHALLENGER
06:30	#1 P.C.P. PASSED TO PACIFIC SHOGUN.
07:55	PACIFIC CHALLENGER AT ANCHOR
09:00	PACIFIC SHOGUN AT ANCHOR
09:00	WAITING FOR CONFIRMATION THAT CASSE IS LATCHED ON DUE TO VIBRATION
09:46	PERMISSION TO PULL SECONDARY ANCHORS
10:50	#1 P.C.P. PACKED
11:00	#5 P.C.P. PACKED
11:15	#5 P.C.P. PASSED TO PACIFIC SHOGUN
11:40	PACIFIC SHOGUN AT ANCHOR #8
11:42	#4 P.C.P. PASSED TO PACIFIC CHALLENGER
11:55	#5 COMMENCED HEAVING IN.
12:15	PACIFIC CHALLENGER AT ANCHOR 4
12:28	#4 AT ROLLER + COMMENCED HEAVING IN #4
13:50	SHOT DOWN IN ANCHOR OPERATIONS AS THIS HULL WAS LIFTED OFF HEAVY
	(SYSTEMS WITH THE OUTLET OF THE (KING KIL STILL ATTACHED TO THE HULL)
14:45	#4 RECOMMENCED HEAVING IN.
15:15	#5 RECOMMENCED HEAVING IN.
15:22	#5 PACKED
15:35	#4 PACKED
15:40	STANDING BY FOR PERMISSION TO PULL PRIMARY ANCHORS
19:05	HELICOPTER ON DECK WITH MAINTENANCE GEAR
19:47	HELICOPTER DEPARTED
20:00	STARTED MESSING GEAR
23:00	ALL CABLES, UTENSILS + EQUIPMENT INSTALLED OPERATIONAL

Forms are to be completed daily in duplicate on all vessels. Each form should be countersigned by the Clients Representative, the original being retained on board until the next crew change or at the end of job, whichever is the earlier, when they should be returned to the PERTH office.

Signature

Well Corporation REPRESENTATIVE

WHITE : Accounts Department
 BLUE : Operations Department
 YELLOW : Client Representative

Signature

W. Edwards CLIENT REPRESENTATIVE



RACAL SURVEY AUSTRALIA LIMITED
DAILY RECORD SHEET

908058 234

Date: *5/10/99* Client: *CUBUS* Job No.: *2930 AB* Vessel: *SARAL 702* Location: *BALDWIN*

PAGE 3 OF

Equipment	Op	
SkyFix		✓
LandStar		✓
Gyro		✓
PCGNS		✓
MultiFix II		✓
GRREP		✓
SkyTrac		

Equipment	Op	
Deso Echo Sounder		
Sidescan		
Boomer		
Heave Co.		
STD-12		
ENSIN		

Racal Personnel
<i>T. LAUREN</i>
<i>C. HARRISON</i>
Client Personnel
<i>R. KAHN</i>

WX	Sea State	Swell	Wind Dir.
0000			
0600			
1200			
1800			

DIARY OF OPERATIONS

TIME	Time Zone = UTC+
	<i>- ALL SYSTEM PARAMETERS CHECKED -</i>
<i>23:45</i>	<i>CHECK FIX STARTED</i>
<i>23:52</i>	<i>CHECK FIX STOPPED SIG 1.89m ON ARRIVAL OF 342.1 FROM BALDWIN 1</i>

Forms are to be completed daily in duplicate on all vessels. Each form should be countersigned by the Clients Representative, the original being retained on board until the next crew change or at the end of job, whichever is the earlier, when they should be returned to the PERTH office.

Signature *[Signature]* Well Completion Recorder
 Signature *[Signature]* Client Representative

WHITE : Accounts Department
 BLUE : Operations Department
 YELLOW : Client Representative

W. Edwards
 Client Representative



RACAL SURVEY AUSTRALIA LIMITED
DAILY RECORD SHEET

Date: 6/11/74 Client: CURTUS Job No.: 2070 03 Vessel: SEAGULL Location: BASEL 2

PAGE 4 OF

Equipment	Op	
SkyFix		✓
LandStar		✓
Gyro		✓
PCGNS		✓
MultiFix II		✓
GRREP		✓
SkyTrac		

Equipment	Op	
Deso Echo Sounder		
Sidescan		
Boomer		
Heave Co.		
STD-12		
ENSIN		

Racal Personnel
T. LAMBERT
C. HANCOCK
Client Personnel
R. KAHN

WX	Sea State	Swell	Wind Dir.
0000			
0600			
1200			
1800			

DIARY OF OPERATIONS

TIME	Time Zone = UTC+
06:15	INITIATED SYSTEMS DUMP + RECHECKED PARAMETERS
06:30	SET GAS COMPASS TO 2-SD-T (4000)
07:30	STARTED SUN SHOTS
08:00	FURNISHED SUN SHOTS (SUN TO LEGAL TO THE SKY) NEED TO REPEAT
09:45	FIXE + ABANDON SHIP DRILL
	- STILL ON STANBY STILL CONNECTED TO HOLE -
10:30	TRACK GUIDANCE LINES CALCULATED + ENTERED INTO GAS COMPASS
12:00	TRACK GUIDANCE LINES FOR DT 5 + DT 100 IN LINES CALCULATED
14:00	ENTERED DRAG POSITIONS OF DT'S @ BASEL 2 (CALCULATED) + ENTERED INTO SYSTEM.
17:00	SYSTEM DISK UPDATED
17:55	COMMENCED 2nd SET OF SUN SHOTS FOR GYRO CALIBRATION.
18:29	PERMISSION TO START ALL ANCHORS (CASING FINALLY CUT)
18:23	#6 P.C.P. PASSED TO PACIFIC CHALLENGER
18:52	#2 P.C.P. PASSED TO PACIFIC SHOGUN.
20:00	CALCULATED GYRO (0-07-0.4) AND ENTERED INTO GAS
20:32	DT 2 @ ROLLER OF PACIFIC SHOGUN + HEADLINE IN
20:45	DT 6 @ ROLLER OF PACIFIC CHALLENGER (REINFORCED CHAIN)
21:05	DT 6 COMMENCED HEADLINE IN.
21:50	DT 2 TACKLED AND P.C.P. PASSED TO REG
22:00	DT 6 TACKLED AND P.C.P. PASSED TO REG
22:34	#3 P.C.P. PASSED TO PACIFIC CHALLENGER
23:03	PACIFIC SHOGUN CONNECTED TO PORT TAIL BRIDLE
23:26	DT 3 @ ROLLER + HEADLINE IN.

Forms are to be completed daily in duplicate on all vessels. Each form should be countersigned by the Clients Representative, the original being retained on board until the next crew change or at the end of job, whichever is the earlier, when they should be returned to the PERTH office.

Signature [Signature]
Well Completion Reporter

WHITE : Accounts Department
BLUE : Operations Department
YELLOW : Clients Representative

Signature [Signature]
CLIENTS REPRESENTATIVE



RACAL SURVEY AUSTRALIA LIMITED

DAILY RECORD SHEET

Date: 7/16/99 Client: CURTIS Job No.: 2975 53 Vessel: SEIKO 702 Location: BALLEN 2

PAGE 5 OF

Equipment	Op	
SkyFix		✓
LandStar		✓
Gyro		✓
PCGNS		✓
MultiFix II		✓
GRREP		✓
SkyTrac		

Equipment	Op	
Deso Echo Sounder		
Sidescan		
Boomer		
Heave Co.		
STD-12		
ENSIN		

Racal Personnel
<u>T. LANGLEY</u>
<u>C. HARKINS</u>
Client Personnel
<u>R. KANST</u>

WX	Sea State	Swell	Wind Dir.
0000			
0600			
1200			
1800			

DIARY OF OPERATIONS

TIME	Time Zone = UTC+
00:40	↓ 3 RACKED
01:05	COMMENCED HEAVING IN ON ↓ 7
01:10	STOPPED HEAVING ON ↓ 7
01:20	PACIFIC CHALLENGER CONNECTED TO STD TEL BRIDGE
01:35	RECOMMENCED HEAVING IN ON ↓ 7
02:30	↓ 7 RACKED
02:30	VESSEL ON TOW.
02:36	1 km OFF LOCATION FIX N: 213 E: 392402 N: 5609128
04:00	φ 39° 39' 6" S / 145° 48' 8" E
08:00	φ 39° 39' 0" S / 146° 02' 0" E
12:00	φ 39° 38' 0" S / 146° 14' 6" E
13:45	BALLEN 2 WELL LOCATION HAS BEEN MOVED 750m TO THE EAST TO E=623.782 N=5,789.65 φ 39° 01' 55" 79 S / 148° 24' 31" 57 E
14:15	BALLEN 2 NEW LOCATION. EDITORIAL AUTO-GS WAVE NETS + T.C. 1503 ALL ADDED TO RESPECT NEW LOCATION.
16:00	φ 39° 37' 0" S / 146° 27' 0" E
20:00	φ 39° 36' S / 146° 39' E.

Forms are to be completed daily in duplicate on all vessels. Each form should be countersigned by the Clients Representative, the original being retained on board until the next crew change or at the end of job, whichever is the earlier, when they should be returned to the PERTH office.

Signature Y.P.
Well Completion Recorder

- WHITE : Accounts Department
- BLUE : Operations Department
- YELLOW : Client Representative

Signature W. Edmund
CLIENTS REPRESENTATIVE



RACAL SURVEY AUSTRALIA LIMITED

DAILY RECORD SHEET

908058 237

Date: 8/10/99 Client: CURTOS Job No.: 2930 AB Vessel: SIDERON Location: SALMON

Equipment	Op
SkyFix	/
LandStar	/
Gyro	/
PCGNS	/
MultiFix II	/
GRREP	/
SkyTrac	

Equipment	Op
Deso Echo Sounder	
Sidescan	
Boomer	
Heave Co.	
STD-12	
ENSIN	

Racal Personnel
<u>T. LAURIEY</u>
<u>C. HANCOCK</u>
Client Personnel
<u>J. LANEY</u>
<u>S. SHAW</u>

WX	Sea State	Swell	Wind Dir.
0000			
0600			
1200			
1800			

DIARY OF OPERATIONS

TIME	Time Zone = UTC+
06:00	<u>39° 35' S 146° 50' E</u>
07:00	<u>39° 26.3 S 147° 02.6 E</u>
08:00	<u>39° 32' S 147° 12' E</u>
11:30	<u>SURVEY CHIEF REP LAUNDED HIS LOG WITH RECORDS</u>
12:00	<u>39° 38.1 S 147° 21.1 E</u>
13:00	<u>RETURNED SYSTEMS RAMP + GYRO CALC + HANDED TO CHIEF REP</u>
14:00	<u>39° 15' S 147° 42' E</u>
21:00	<u>39° 05' S 147° 42' E</u>
21:05	<u>POWER FAILURE ALL NAV CLEAR DOWN.</u>
22:10	<u>SYSTEM BACK UP + RUNNING</u>
23:00	<u>POWER FAILURE ALL NAV CLEAR DOWN.</u>
23:16	<u>SYSTEM BACK UP + RUNNING</u>

Forms are to be completed daily in duplicate on all vessels. Each form should be countersigned by the Clients Representative, the original being retained on board until the next crew change or at the end of job, whichever is the earlier, when they should be returned to the PERTH office.

Signature [Signature]
Well Completion Recorder

WHITE : Accounts Department
 BLUE : Operations Department
 YELLOW : Client Representative

Signature [Signature]
CLIENT REPRESENTATIVE



RACAL SURVEY AUSTRALIA LIMITED
DAILY RECORD SHEET

Date: 9/14/99 Client: CULTUS Job No.: 2930 AS Vessel: SEXY 702 Location: BALLEN 2

PAGE 7 OF

Equipment	Op
SkyFix	✓
LandStar	✓
Gyro	✓
PCGNS	✓
MultiFix II	✓
GRREP	✓
SkyTrac	

Equipment	Op
Deso Echo Sounder	
Sidescan	
Boomer	
Heave Co.	
STD-12	
ENSIN	

Racal Personnel
T. LANGLEN
C. HANCOCK
Client Personnel
R. HANCOCK
D. SIMON

WX	Sea State	Swell	Wind Dir.
0000			
0600			
1200			
1800			

DIARY OF OPERATIONS

TIME	Time Zone = UTC+
00:01	$39^{\circ} 02' 55''$ S / $147^{\circ} 51' 5''$ E
00:06	ANOTHER POWER FAILURE
04:00	$38^{\circ} 56' S$ / $148^{\circ} 05' 6''$ E
07:21	SYSTEM UP + RUNNING
08:00	$38^{\circ} 50' 15''$ S / $148^{\circ} 14' 5''$ E
11:00	$38^{\circ} 46' 75''$ S / $148^{\circ} 22' 1''$ E
12:00	$38^{\circ} 41' 25''$ S / $148^{\circ} 32' 2''$ E
18:00	$38^{\circ} 35' 55''$ S / $148^{\circ} 38' 0''$ E

Forms are to be completed daily in duplicate on all vessels. Each form should be countersigned by the Clients Representative, the original being retained on board until the next crew change or at the end of job, whichever is the earlier, when they should be returned to the PERTH office.

Signature [Handwritten Signature]
 Well Completion Engineer

WHITE : Accounts Department
 BLUE : Operations Department
 YELLOW : Client Representative

Signature [Handwritten Signature]
 Client Representative



RACAL SURVEY AUSTRALIA LIMITED
DAILY RECORD SHEET

Date: 14/1/79 Client: CUIUS Job No.: 275 B3 Vessel: SERRA Location: BALISEL 2

Table with columns: Equipment, Op, Status. Rows include SkyFix, LandStar, Gyro, PCGNS, MultiFix II, GRREP, SkyTrac.

Table with columns: Equipment, Op, Status. Rows include Deso Echo Sounder, Sidescan, Boomer, Heave Co., STD-12, ENSIN.

Table with columns: Rascal Personnel, Client Personnel. Lists names of crew members.

Table with columns: WX, Sea State, Swell, Wind Dir. Rows for times 0000, 0600, 1200, 1800.

DIARY OF OPERATIONS

Large table for diary of operations with columns for TIME and Time Zone = UTC+. Contains detailed log of operations from 00:00 to 19:32.

Forms are to be completed daily in duplicate on all vessels. Each form should be countersigned by the Clients Representative, the original being retained on board until the next crew change or at the end of job, whichever is the earlier, when they should be returned to the PERTH office.

Signature Well Completion Engineer

WHITE : Accounts Department
BLUE : Operations Department
YELLOW : Clients Representative

Signature W. Edwards
CLIENT REPRESENTATIVE



RACAL SURVEY AUSTRALIA LIMITED
DAILY RECORD SHEET

908058 240

Date: 10.10.99 Client: CULIUS Job No.: 2930 A3 Vessel: Sedco 702 Location: BALEEN-2

Equipment	Op	
SkyFix	✓	
LandStar	✓	
Gyro	✓	
PCGNS	✓	
MultiFix II	✓	
GRREP	✓	
SkyTrac		

Equipment	Op	
Deso Echo Sounder		
Sidescan		
Boomer		
Heave Co.		
STD-12		
ENSIN		

Racal Personnel
T. LANGLEY
C. HAKKENES
Client Personnel
R. KAHUR
B. EDMONDS

WX	Sea State	Swell	Wind Dir.
0000			
0600			
1200			
1800			

DIARY OF OPERATIONS

TIME	Time Zone = UTC+
21:00	↓ 8 OTB Fix 522 (P. SHOCUN)
21:12	↓ 4 OTB Fix 526 (P. CHALLOKON)
	- U23 STARTED TO SEED MUDS TO BE 22- RUN -
23:07	↓ 3 OTB (2nd TIME) FIX 542
23:44	START OF PRELUSION OF U2 + U6
23:59	U2 + U6 PASS TENSION.

Forms are to be completed daily in duplicate on all vessels. Each form should be countersigned by the Clients Representative, the original being retained on board until the next crew change or at the end of job, whichever is the earlier, when they should be returned to the PERTH office.

Signature [Signature] SURVEYOR/ENGINEER

WHITE : Accounts Department
BLUE : Operations Department
YELLOW : Clients Representative

Signature [Signature] CLIENT REPRESENTATIVE



RACAL SURVEY AUSTRALIA LIMITED

DAILY RECORD SHEET

Date: 11/1/99 Client: CUTEUS Job No.: 2970 AS Vessel: SWYKOSTON Location: BALLEN 2

Equipment	Op	
SkyFix	/	
LandStar	/	
Gyro	/	
PCGNS	/	
MultiFix II	/	
GRREP	/	
SkyTrac		

Equipment	Op	
Deso Echo Sounder		
Sidescan		
Boomer		
Heave Co.		
STD-12		
ENSIN		

Racal Personnel
T. LANGLEY
C. WALKER

WX	Sea State	Swell	Wind Dir.
0000			
0600			
1200			
1800			

DIARY OF OPERATIONS

TIME	Time Zone = UTC+
08:00	START OF PRETENSION (350 KPS)
08:20	PASS PRETENSION.
08:42	START OF PRETENSION.
09:00	PASS PRETENSION.
09:05	START OF PRETENSION.
09:14	PASS PRETENSION.
09:20	START TO MOVE REG OVER 45m @ 29K
09:35	STOPPED HEAVE CO.
	L1 @ 142° L=2432
	L2 @ 157° L=2390
	L3 @ 232° L=2442
	L4 @ 271° L=2308
	L5 @ 322° L=2360
	L6 @ OUT L=2790
	L7 @ 052° L=2193
	L8 @ 097° L=2411
09:51	STARTED FINAL FIX.
09:59	FINAL FIX STOPPED (350 KPS)
	SAVED ALL SYSTEM DATA - PRINTED SCREENS AND
	REG LOG @ 32K FINAL INTENDED LOCATED.
10:00	FINAL FIX REPORT + SCREENS PRESENTED TO CLIENT REP
10:00	STARTED DEMOS
11:00	FINISHED DEMOS 13x BUS 2D CUTAWAY (002) HELIX DATA
14:30	PREPARED REG.

Forms are to be completed daily in duplicate on all vessels. Each form should be countersigned by the Clients Representative, the original being retained on board until the next crew change or at the end of job, whichever is the earlier, when they should be returned to the PERTH office.

Signature [Signature]
Well Completion Planner

- WHITE : Accounts Department
- BLUE : Operations Department
- YELLOW : Clients Representative

Signature [Signature]
VIC/PL 5 Balcon 2
CLIENT REPRESENTATIVE

APPENDIX 2.

HYDROGRAPHIC SURVEYS PTY. LTD.

SERVICES IN THE OCEAN SCIENCES

A.C.N. 001 325 186

ENGINEERING-HYDROGRAPHIC-OCEANOGRAPHIC-ENVIRONMENTAL-GEOPHYSICAL INVESTIGATIONS

21 LYNWOOD STREET, BLAKEHURST, NSW, 2221, AUSTRALIA

TEL: +61 2 95467536

FX: +61 2 95464768

MOBILE: 0412113921

MOBILE FAX: 0412216607

E-MAIL: syzygy@zip.com.au

**NOTIFICATION OF FINAL RIG POSITION**

TO; Gordon Nicholl CULTUS Drilling Superintendent (02 9418 1504)
 CC; Vaughan Till CULTUS Senior Geophysicist
 Ray Kohut Drilling Supervisor
 FROM; Bill Edmonds Surveyor
 DATE; 11 October, 1999 3:13

FINAL DRILLSTEM COORDINATES COMPUTED BY DGPS

NAME OF LOCATION; BALEEN 2
 RIG NAME; SEDCO 702 PERMIT NAME; Vic/RL5
 LATITUDE; 38°01'55.76" South
 LONGITUDE; 148°24'37.55" East
 EASTINGS; 623 781.41 m
 NORTHINGS; 5 789 663.90 m
 FINAL RIG HEADING; 206.4° True

This is a distance of 1.08m on a bearing of 326 degrees FROM the proposed location.

PROPOSED LOCATION

LATITUDE; 38°01'55.79" LONGITUDE; 148°24'37.57"
 EASTING; 623 782 m NORTHING; 5 789 663 m
 PROPOSED RIG HEADING; 210° WATER DEPTH (approx); 59m
 DATUM; ANS AGD 66 CENTRAL MERIDIAN; 147° ZONE; 55 EAST

Survey
02:51:28 11 Oct 1999

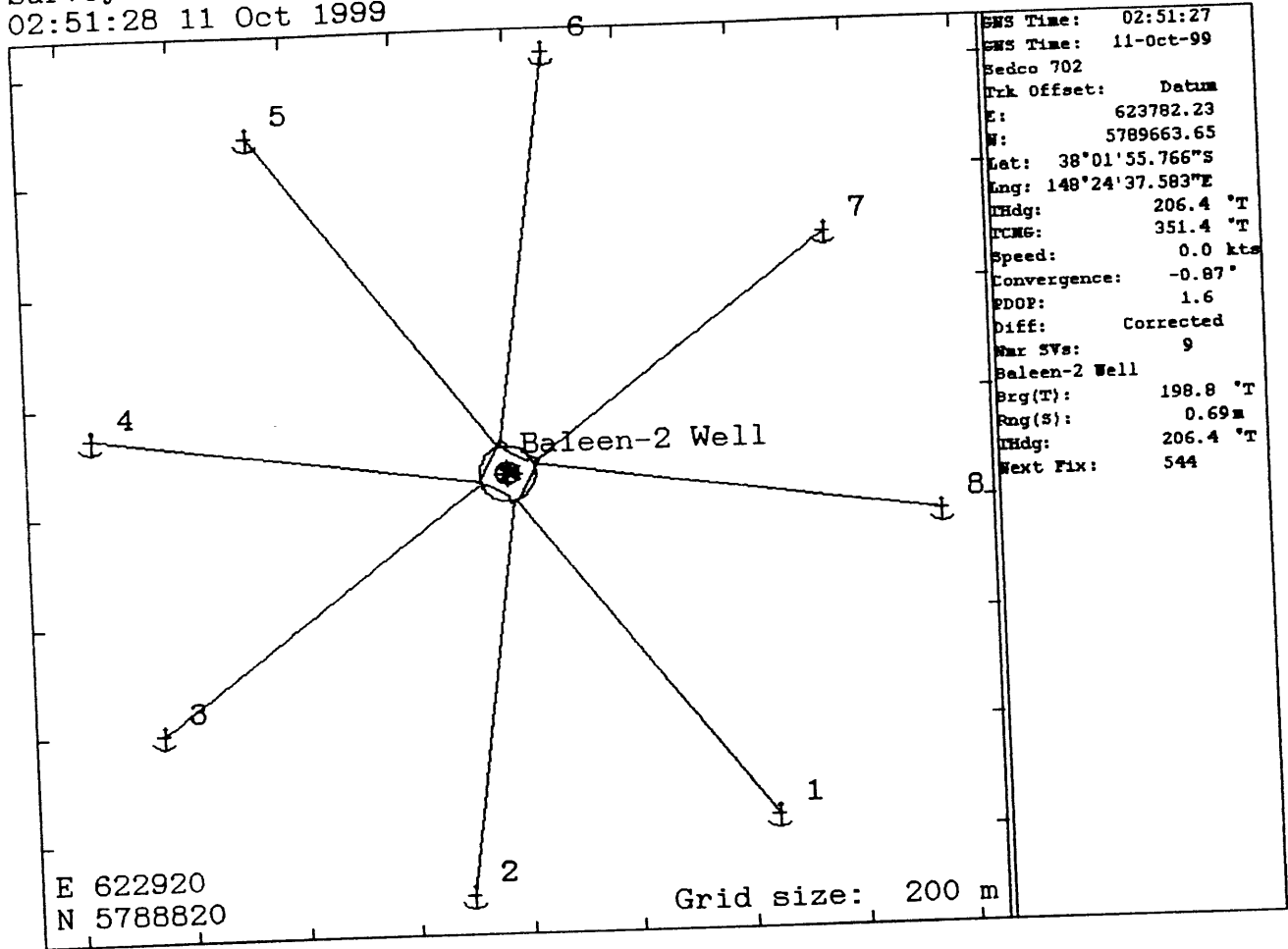

02:54:40 11 Oct 1999

Sedco 702
Fairleads Actual 1
Brg(T): 141.9 °T
Rng(S): 2429.44ft
Fairleads Actual 2
Brg(T): 187.0 °T
Rng(S): 2389.67ft
Fairleads Actual 3
Brg(T): 232.0 °T
Rng(S): 2412.59ft
Fairleads Actual 4
Brg(T): 277.0 °T
Rng(S): 2308.20ft
Fairleads Actual 5
Brg(T): 322.0 °T
Rng(S): 2358.79ft
Fairleads Actual 6
Brg(T): 7.0 °T
Rng(S): 2358.54ft
Fairleads Actual 7
Brg(T): 52.0 °T
Rng(S): 2192.39ft
Fairleads Actual 8
Brg(T): 97.0 °T
Rng(S): 2410.12ft

RACAL Racial Survey Group Ltd
FINAL POSITION FIX – DIFFERENTIAL GPS

Job: Survey
 Job Number: 2930A3
 Racial Surveyor: Troy Langley
 Client: Cultus Petroleum
 Client Representative: R.Kahut

Sampling started: 11 Oct 1999 01:58:00
 Sampling end: 11 Oct 1999 02:39:28

Sedco 702

Intended datum location

Datum: AGD66
 Latitude: 38°01'55.787"S Longitude: 148°24'37.574"E
 Projection: AMG Zone 55
 Easting: 623782.00 Northing: 5789663.00

Final Antenna Position (R1 Racial UKOOA):

Sample size: 249 fixes used out of a total of 250.

Antenna offset
 X: 1.90m Y: 35.80m Z: 0.00m
 Range: 35.85m Rel Brg from datum to antenna: 3.0°

Datum: WGS 84 Spheroidal Ht: 28.31m
 Latitude: 38°01'51.254"S Longitude: 148°24'41.369"E
 Datum: AGD66 Spheroidal Ht: 35.29m
 Latitude: 38°01'56.779"S Longitude: 148°24'36.845"E
 Projection: AMG Zone 55 Spheroidal Ht: 35.29m
 Easting: 623763.77 Northing: 5789632.69

Standard deviations

Long or E: 0.31m
 Lat or N: 0.26m
 Height: 0.79m
 Position: 0.41m

Final Datum Position

Datum: AGD66 Spheroidal Ht: 35.29m
 Latitude: 38°01'55.758"S Longitude: 148°24'37.549"E
 Projection: AMG Zone 55 Spheroidal Ht: 35.29m
 Easting: 623781.41 Northing: 5789663.90

Mean corrected heading: 206.4°T
 SD heading: 0.0°T
 Intended heading: 210.0°T
 Difference from intended: -3.6°

Final Datum Position is 1.08m on a bearing of 326.0°T (326.9°G) from the intended location.

GNS II CONFIGURATION FILE C:\CultusBaleen2\CultusBaleen2.gns

JOB DETAILS

Job Number : 2930A3
 Job Description : Survey
 Company : Racal Survey Group Ltd
 Client : Cultus Petroleum

WORKING SPHEROID

AGD66
 Semi-major : 6378160.000 m
 e Squared : 0.006694541855

WORKING PROJECTION

AMG Zone 55
 Lat of Origin : 00°00'00.000"N
 Long of Origin : 147°00'00.000"E
 False Easting : 500000.00
 False Northing : 10000000.00
 Scale Factor : 0.999600
 Units : Metres

GPS TRANSFORMATION

From : WGS 84
 Semi-major : 6378137.000 m
 e Squared : 0.006694380067
 To : AGD66
 Dx : 123.314 m
 Dy : 47.223 m
 Dz : -136.594 m
 Rot x : 0.2640 secs
 Rot y : 0.3220 secs
 Rot z : 0.2700 secs
 Scale : 1.3840 ppm

WAYPOINTS

Baleen-2 Well	E: 623782.00	N: 5789663.00	Ht: 0.00 m	Tol1: 20.00 m	Tol2:
Barramundi	E: 391413.90	N: 5609012.80	Ht: 0.00 m	Tol1: 0.00 m	Tol2:10
Blackback	E: 635083.02	N: 5732929.69	Ht: 0.00 m	Tol1: 0.00 m	Tol2:50
Wp1	E: 471391.60	N: 5613794.43	Ht: 0.00 m		
WP2	E: 613571.97	N: 5701815.09	Ht: 0.00 m		
WP3	E: 645808.83	N: 5723490.75	Ht: 0.00 m		
WP4	E: 642076.21	N: 5758710.00	Ht: 0.00 m		
WP5	E: 635874.46	N: 5780091.16	Ht: 0.00 m		
WP6	E: 627324.32	N: 5794103.13	Ht: 0.00 m		
WP7	E: 628494.27	N: 5793211.56	Ht: 0.00 m		

TRACK GUIDANCE

anch 6
 SOL E: 623889.90 N: 5790557.30

EOL E: 623773.00 N: 5789712.50 K1

Verified by: (sign) _____ (print) _____

01:54 11-Oct-99

GNS II CONFIGURATION FILE C:\CultusBaleen2\CultusBaleen2.gns

Anch 7
 SOL E: 624364.31 N: 5790083.37 EOL E: 623829.80 N: 5789678.68 KJ
 run in 7
 SOL E: 635874.50 N: 5780091.10 KP: 0.000 EOL E: 630886.00 N: 5792587.00 KJ
 SOC E: 630886.00 N: 5792587.00 KP: 13.457 EOC E: 628481.00 N: 5793216.00 KJ
 CC E: 629386.41 N: 5791765.56 Radius: 1709.83 m
 SOL E: 628481.00 N: 5793216.00 KP: 16.241 EOL E: 623829.00 N: 5789679.00 KJ

MOBILES

Sedco 702 (semi-sub rig)

Shape: Sedco702

SOL:-

X: 0.00 m Y: 35.00 m
 X: -22.90 m Y: 35.00 m
 X: -30.50 m Y: 45.70 m
 X: -38.10 m Y: 35.00 m
 X: -38.10 m Y: -45.70 m
 X: -22.90 m Y: -45.70 m
 X: -22.90 m Y: -35.00 m
 X: 22.90 m Y: -35.00 m
 X: 22.90 m Y: -45.70 m
 X: 38.10 m Y: -45.70 m
 X: 38.10 m Y: 35.00 m
 X: 30.50 m Y: 45.70 m
 X: 22.90 m Y: 35.00 m
 X: 0.00 m Y: 35.00 m

Offsets:-

Datum	X: 0.00 m	Y: 0.00 m	Z: 0.00 m	Rng: 0.00 m	Brg: 35.85 m
gps1	X: 1.90 m	Y: 35.80 m	Z: 0.00 m	Rng: 50.33 m	Brg: 50.33 m
Winch 7	X: -33.00 m	Y: -38.00 m	Z: 0.00 m	Rng: 50.33 m	Brg: 50.33 m
Winch 6	X: 33.00 m	Y: -38.00 m	Z: 0.00 m	Rng: 50.33 m	Brg: 50.33 m

Tracking Point : Datum
 Pitch and Roll Centre: Datum

Selected Sources:-

Primary Position : R1 Racal UKOOA
 Primary Heading : S1 SGB 1000S
 Primary Height : Datum Displacement
 Pitch and Roll : Manual
 Soundings : Manual
 Speed : Position Filter
 Course Made Good : Posn Filter CMG

Equipment:-

R1 Racal UKOOA

Verified by: (sign) _____ (print) _____

01:54 11-Oct-99

GNS II CONFIGURATION FILE C:\CultusBaleen2\CultusBaleen2.gns

Status: ON Interface: COM3
 Ant: gps1 X: 1.90 m Y: 35.80 m Z: 0.00 m Rng: 35.85 m
 Apply Pitch and Roll: Off Stale Time: 5.0 s Posn SD: 3.0 m Ht SD: 1.0 m

S1 SGB 1000S
 Status: ON Interface: COM7
 C-O: -0.4 degs Stale Time: 5.0 s SD: 0.1 degs

ANCHORS

Sedco 702

Fairleads:-								
Fairlead 1	X: -35.00 m	Y: 35.00 m	Z: 0.00 m	Rng: 49.50 m	Brg: 31			
Fairlead 2	X: -33.00 m	Y: 38.00 m	Z: 0.00 m	Rng: 50.33 m	Brg: 31			
Fairlead 3	X: 33.00 m	Y: 38.00 m	Z: 0.00 m	Rng: 50.33 m	Brg: 31			
Fairlead 4	X: 35.00 m	Y: 35.00 m	Z: 0.00 m	Rng: 49.50 m	Brg: 31			
Fairlead 5	X: 35.00 m	Y: -35.00 m	Z: 0.00 m	Rng: 49.50 m	Brg: 11			
Fairlead 6	X: 33.00 m	Y: -38.00 m	Z: 0.00 m	Rng: 50.33 m	Brg: 11			
Fairlead 7	X: -33.00 m	Y: -38.00 m	Z: 0.00 m	Rng: 50.33 m	Brg: 21			
Fairlead 8	X: -35.00 m	Y: -35.00 m	Z: 0.00 m	Rng: 49.50 m	Brg: 21			

Main Intended Positions:-

Anchor 1	E: 624244.75	N: 5789026.58	Dep: 0.00 m	Tol: 0.00 m
Anchor 2	E: 623694.46	N: 5788893.21	Dep: 0.00 m	Tol: 0.00 m
Anchor 3	E: 623149.25	N: 5789201.08	Dep: 0.00 m	Tol: 0.00 m
Anchor 4	E: 623038.21	N: 5789744.44	Dep: 0.00 m	Tol: 0.00 m
Anchor 5	E: 623333.06	N: 5790283.60	Dep: 0.00 m	Tol: 0.00 m
Anchor 6	E: 623868.84	N: 5790424.30	Dep: 0.00 m	Tol: 0.00 m
Anchor 7	E: 624361.79	N: 5790085.05	Dep: 0.00 m	Tol: 0.00 m
Anchor 8	E: 624556.81	N: 5789577.73	Dep: 0.00 m	Tol: 0.00 m

Main Actual Positions:-

Anchor 1	E: 624244.75	N: 5789026.58	Dep: 0.00 m	Tol: 0.00 m
Anchor 2	E: 623694.46	N: 5788893.20	Dep: 0.00 m	Tol: 0.00 m
Anchor 3	E: 623149.25	N: 5789201.07	Dep: 0.00 m	Tol: 0.00 m
Anchor 4	E: 623038.20	N: 5789744.40	Dep: 0.00 m	Tol: 0.00 m
Anchor 5	E: 623333.10	N: 5790283.60	Dep: 0.00 m	Tol: 0.00 m
Anchor 6	E: 623868.84	N: 5790424.30	Dep: 0.00 m	Tol: 0.00 m
Anchor 7	E: 624361.80	N: 5790085.05	Dep: 0.00 m	Tol: 0.00 m
Anchor 8	E: 624556.80	N: 5789577.70	Dep: 0.00 m	Tol: 0.00 m

Verified by: (sign) _____ (print) _____

348 e 9-Oct-1999 13:19:09 Logging: ON

702 Offset Datum X: 0.00m Y: 0.00m
E: 622695.14 N: 5709516.87 Ht(S): 34.46m Lat: 38°45'15.809"S Lng: 148°24'43.318"E
E: 622721.92 N: 5709540.69
E: 622644.92 N: 5709513.61
E: 622691.32 N: 5709466.69

T Corr: -0.4 Spd: 2.5kts Pitch: ???* Roll: ???* Heave: ???m Sounding: ???m
Rng: 27009.49m Brq: 58.8*G

Line: Sedco --Seq 3
Datum UK00A (Tracking) Datum E: 622695.14 N: 5709516.87 Ht(S): 34.46m
anna Lat: 38°45'09.507"S Lng: 148°24'48.978"E Ht: 25.50m
ordinate Conversions:
ng the WGS 84 to AGD66 transformation

38°27'18.709"S	147°04'37.121"E	0.000	WGS 84
-4197984.637	2718191.414	-3945135.971	WGS 84
-4197857.416	2718242.845	-3945288.057	AGD66
38°27'24.180"S	147°04'32.489"E	10.080	AGD66

(HODDINOTTS 1.5.)

-ordinate Conversions:			AGD66
38°01'55.790"S	148°24'37.570"E	0.000	ANG Zone 55
E 623781.910	N 5789662.914	0.000	

(BACGEN 2 PROPOSED)

SPADE (v4.2) Copyright (c) 1991 Michael R. Craymer
2930A3-2nd

Date : 6 Oct 1999
Method : Solar Hour Angle
Latitude (D.MMSSs) : -39.3937
Longitude West (D.MMSSs) : -145.4407
Watch Corr: UT-Watch (H.MMSSs) : 0.00000
Error in Latitude (arcsec) : 5.0
Error in Timing (sec of time) : 0.5
Output Filename : BALEEN2

Set No.	Average Watch Time (HH.MMSSs)	Average Horz.Ang (DD.MMSSs)	Azimuth Star (DD.MMSSs)	Azimuth RO (HH.MMSSs)
1	7.5900	56.5200	267.0950	210.1750
0.0005				
2	8.0000	56.4200	267.0018	210.1818
0.0005				
3	8.0030	56.3600	266.5532	210.1932
0.0005				
4	8.0130	56.5000	266.4559	209.5559
0.0005				
5	8.0200	56.1700	266.4113	210.2413
0.0005				
6	8.0230	56.2800	266.3626	210.0826
0.0005				
7	8.0300	56.0600	266.3140	210.2540
0.0005				
8	8.0330	56.1200	266.2654	210.1454
0.0005				
9	8.0400	56.0700	266.2207	210.1507
0.0005				
10	8.0430	56.0400	266.1721	210.1321
0.0005				

Average Azimuth

Set No.	Azimuth RO (DD.MMSSs)	Error (DD.MMSSs)
1	210.1750	0.0005
2	210.1818	0.0005
3	210.1932	0.0005
4	209.5559	0.0005
5	210.2413	0.0005
6	210.0826	0.0005
7	210.2540	0.0005

8	210.1454	0.0005
9	210.1507	0.0005
10	210.1321	0.0005

Average Azimuth RO : 210.1520

2nd Gyro Calibration #2930A3 Cultus Petroleum Sedco 702 6 Oct 1999

Gyro

Time	Observations	Computed Azimuth	Observed Grid	Convergence	TRUE	C-0
17:59:00	1	210.30	209.9	0.81	210.71	-0.4
18:00:00	2	210.31	209.9	0.81	210.71	-0.4
18:00:30	3	210.33	209.9	0.81	210.71	-0.4
18:01:30	4	209.93	209.9	0.81	210.5	-0.6
18:02:00	5	210.40	209.9	0.81	210.71	-0.3
18:02:30	6	210.14	209.9	0.81	210.71	-0.6
18:03:00	7	210.43	210.0	0.81	210.81	-0.4
18:03:30	8	210.25	209.8	0.81	210.61	-0.4
18:04:00	9	210.25	209.7	0.81	210.51	-0.3
18:04:30	10	210.22	209.8	0.81	210.61	-0.4
Average=						-0.4



CULTUS PETROLEUM NL

**POSITIONING REPORT
OF THE DRILLING RIG SEDCO 702**

LOCATION : **BALEEN-2**
PERMIT : **VIC/RL5**
DATE : **4 – 11 OCTOBER 1999**
REPORT REF : **2930A3**

		Page No.
Location map		
1.	INTRODUCTION	4
2.	SUMMARY	6
	2.1 Requirements	6
	2.2 Summary of Events	7
3.	FINAL RIG POSITION	8
	3.1 Final Differential GPS Position	8
	3.2 Anchor Positions	9
4.	GEODETIC PARAMETERS	10
	4.1 Datums	10
	4.2 Projection	10
	4.3 Datum Transformation	10
	4.4 Geoid Spheroid Separation	11
5.	EQUIPMENT CHECKS AND CALIBRATIONS	12
	5.1 Check Fix at Barramundi-1	12
	5.2 Gyro Calibration	13
6.	GLOBAL POSITIONING SYSTEM (GPS)	14
	6.1 System Description	14
	6.2 GPS Observations	15
	6.3 Differential GPS (DGPS)	16
	6.4 SkyFix/SkyFix Spot Differential Link	17
	6.5 Trimble Series 4000 GPS Receiver	18
	6.6 MultiFix II	19
7.	SAFETY	24
8.	PERSONNEL AND EQUIPMENT	25
	8.1 Personnel	25
	8.2 Equipment	26
9.	DISTRIBUTION	27

- 
- A - OFFSET DIAGRAM – SEDCO 702
 - B - DIFFERENTIAL GPS FINAL FIX PRINTOUTS
 - C - SYSTEM DATA PRINTOUTS
 - D - DIFFERENTIAL GPS CHECK FIX AT BARRAMUNDI-1
 - E - GYRO CALIBRATION
 - F - GRAPHIC DUMPS ON FINAL LOCATION
 - G - DAILY LOG SHEETS

GENERAL LOCATION DIAGRAM

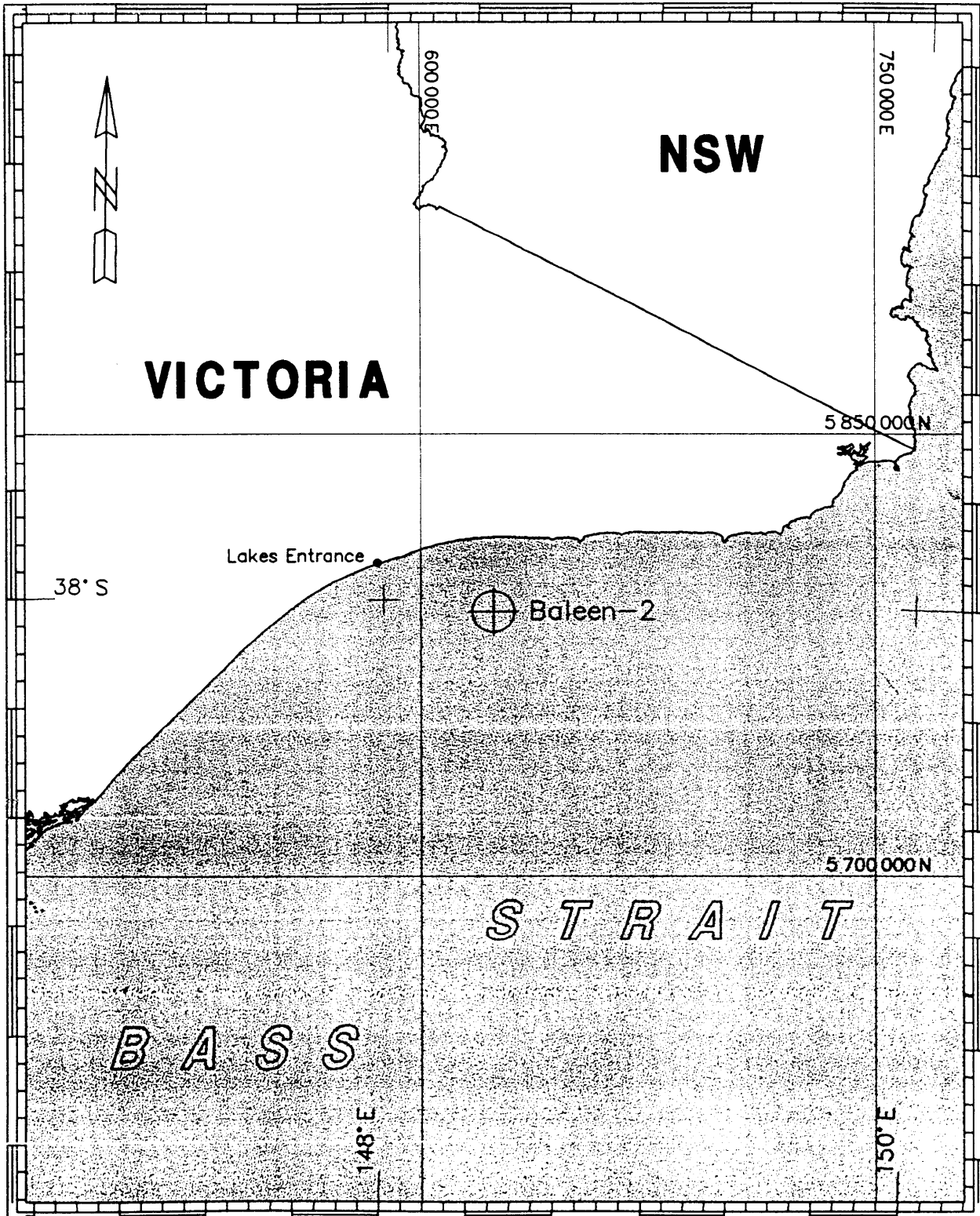

Coastline data is © Commonwealth of Australia, AUSLIG 1998. All rights reserved.

1. INTRODUCTION

This report details the services provided by Racal Survey Australia Limited (Racal), during positioning of the semi-submersible drilling rig, Sedco 702, at the Baleen-2 location in Bass Strait, for Cultus Petroleum NL (Cultus).

Racal Personnel T. Langley and C. Hakkennes were mobilised to the Sedco 702 from Perth and Victoria respectively on 4 October 1999 arriving onboard the rig at 1421. The rig was located at the Barramundi-1 location.

Positioning of the Sedco 702 at the Baleen-2 location was provided by Racal's SkyFix/SkyFix Spot Differential GPS (DGPS), interfaced to Racal's Multi Reference Station Software, MultiFix II.

Anchor recovery at the Barramundi-1 location commenced at 0830 on 5 October 1999. Anchor operations were suspended at 1540, when the secondary anchors were racked, due to the rig's inability to detach from the well. Anchor operations recommenced at 1829 on 6 October 1999, after the well casing was finally cut. The last anchor was racked at 0230 on 7 October 1999 and the tow commenced at 0230.

Anchor deployment commenced at the Baleen-2 location with the number 7 anchor being lowered to the seabed while the rig was towed onto the location at 1150 on 10 October 1999. The anchor deployment operation was completed at 2307 on 10 October 1999.

Tensioning of anchor chains and ballasting was completed and the position was accepted by the Client Representative at 0159 on 11 October 1999.

The co-ordinates of the intended Baleen-2 location were provided by Cultus as follows

Intended Baleen-2 Location

Datum AGD 66

Latitude : 38° 01' 55.79" South
Longitude : 148° 24' 37.57" East

AMG Zone 55 C.M. 147° East

Easting : 623 782m
Northing : 5 789 663m

Differential GPS Position Baleen-2

The Differential GPS position of the drillstem of the Sedco 702 was computed from data observed between 0158 and 0239 on 11 October 1999. The final computed Differential GPS position of the drillstem was as follows:

Datum: AGD 66

Latitude : 38° 01' 55.758" South
Longitude : 148° 24' 37.549" East

Projection: AMG Zone 55 C.M. 147° East

Easting : 623 781.41m
Northing : 5 789 663.90m

The Differential GPS position of the drillstem is 1.08 metres on a bearing of 326.0° (T) from the intended Baleen-2 location.

Final Rig Heading : 206.4° (T)

2. SUMMARY

2.1 REQUIREMENTS

Racal Survey Australia Limited were contracted by Cultus Petroleum NL to provide personnel and positioning equipment consisting of Racal's SkyFix/SkyFix Spot Differential GPS for the rig move of the Sedco 702 from the Barramundi-1 location to the Baleen-2 location. Racal's GNS II software was used to provide online navigation of the drilling rig and the final drillstem position.

The requirements were as follows:

- (a) All equipment, personnel and services necessary to position the semi-submersible drilling rig Sedco 702 at the Baleen-2 location.
- (b) A navigation position check at the existing Barramundi-1 location prior to departure for the Baleen-2 location.
- (c) The calibration of the survey gyrocompass, to determine the computed minus observed value.
- (d) The determination of the final drillstem position over the Baleen-2 location by a Multiple Reference Station Differential GPS final fix.
- (e) The provision of a comprehensive Positioning Report containing the final location values.

2.2 SUMMARY OF EVENTS

Racal Personnel T. Langley and C. Hakkennes travelled to Melbourne from Perth and Benalla respectively on 4 October 1999 and arrived onboard the Sedco 702 at 1421. At 1440 T. Langley and C. Hakkennes undertook the rig induction.

At 1600 a pre rig move meeting was attended by T. Langley and C. Hakkennes. No possible problems were identified with the move.

On 5 October 1999 at 0830, anchor recovery commenced at the Barramundi 1 location. Anchor operations were suspended at 1540 after the secondary anchors were racked (No's 1,4,5,8) due to problems in detaching from the well.

Racal's positioning equipment arrived onboard the Sedco 702 at 1905 on 5 October 1999. Mobilisation began at 2000 with all cables and navigation equipment being operational by 2300. The system parameters were printed and checked. A check fix was started at 2345 and stopped at 2352. The rig of 1.89 metres at a bearing of 342.1° from the Barramundi 1 well location.

At 0730 on 6 October 1999, sun shots were observed for the gyro calibration. However, as the sun was too high in the sky, another set needed to be performed. At 0945 a fire and abandonment drill was held and attended by all personnel. At 1400 all the intended anchor drop positions and track guidance lines were calculated and entered into the GNSII computer. At 1755 a second set of sun shots were performed and at 2000 a C-O of -0.41° was entered into GNSII.

Anchor handling operations recommenced at 1829 after the rig was detached from the well. All anchors were racked at 0230 on 7 October 1999 and the tow commenced at 0230. The tow boats were the Pacific Commander and the Pacific Shogun.

During the tow from the Barramundi-1 location to the Baleen-2 location, the position of the Sedco 702 was recorded at 30min intervals.

On 8 October 1999, at 1130, the Client Survey Representative W. Edmonds arrived on the rig.

At 0900 on 10 October 1999, the systems parameters were rechecked prior to arrival at location. At 1000 another abandon rig drill was held and this was attended by all personnel.

At 1015 the rig started to run in on anchor 7. Anchor 7 was dropped at 1150, with the last anchor being dropped at 2112. Anchors 2, 3 and 6 required re running due to them slipping. Pre-tensioning of anchors commenced at 2344 and was finished at 0114 on 11 October 1999. At 0135 the rig was winched towards the well location and at 0159 the rig's position was accepted by the Client Representative.

The final Differential GPS fix at the Baleen-2 location was observed between 0159 and 0239 on 11 October 1999 with the rig being 1.08 metres at a bearing of 326 degrees from intended well location.

Demobilisation of the navigation equipment commenced at 0800 and was completed by 1100. T. Langley and C. Hakkennes then departed the rig at 1430.

3. FINAL RIG POSITION

3.1 FINAL DIFFERENTIAL GPS POSITION

The Sedco 702 was positioned over the Baleen-2 location on 10 October 1999.

A Differential GPS final fix of the Sedco 702 was computed using the SkyFix/SkyFix Spot Differential GPS. Between 0158 and 0239 on 11 October 1999, 250 sample positions taken at 10 second intervals were observed.

The computed antenna position was as follows:

Datum: WGS 84

Latitude	:	38° 01' 51.254" South	(S.D. 0.31m)
Longitude	:	148° 24' 41.369" East	(S.D. 0.26m)
Spheroidal Height	:	28.31m	(S.D. 0.79m)

Transforming the above WGS 84 co-ordinates to AGD 66 using the parameters in section 4, gives the following co-ordinates:

Datum: AGD 66

Latitude	:	38° 01' 56.779" South
Longitude	:	148° 24' 36.845" East
Spheroidal Height	:	35.29m

By applying a distance of 35.85m on a bearing of 29.4° (T) from the antenna position the following drillstem co-ordinates were calculated:

Datum: AGD 66

Latitude	:	38° 01' 55.758" South
Longitude	:	148° 24' 37.549" East

Projection: AMG Zone 55 C.M. 147° East

Easting	:	623 781.41m
Northing	:	5 789 663.90m

This position is 1.08 metres on a bearing of 326.0° (T) from the intended Baleen-2 location.

Final Rig Heading : 206.4° (T)

3.2 ANCHOR POSITIONS

The table below lists the anchor deployment positions:

Datum: AGD 66 Projection: AMG Zone 55, C.M. 147° East

Main Anchors	Deployment	
	Easting (m)	Northing (m)
Anchor 1	624 244.75	5 789 026.58
Anchor 2	623 694.46	5 788 893.20
Anchor 3	623 149.25	5 789 201.07
Anchor 4	623 038.20	5 789 744.40
Anchor 5	623 333.10	5 790 283.60
Anchor 6	623 868.84	5 790 424.30
Anchor 7	624 372.70	5 790 088.20
Anchor 8	624 556.80	5 789 577.70

4. GEODETIC PARAMETERS

Co-ordinates shown in this report are referenced to Australian Geodetic Datum 1966 (AGD 66).

The Global Positioning System (GPS) is referenced to the World Geodetic System 1984 (WGS 84).

4.1 DATUMS

Datum	:	Australian Geodetic Datum 1966
Spheroid	:	Australian National
Semi-major Axis (a)	:	6 378 160.000m
Semi-minor Axis (b)	:	6 356 774.719m
Eccentricity Squared (e^2)	:	0.006 694 542
Flattening ($1/f$)	:	298.25

Datum	:	World Geodetic System 1984
Spheroid	:	WGS 84
Semi-major Axis (a)	:	6 378 137.000m
Semi-minor Axis (b)	:	6 356 752.3142m
Eccentricity Squared (e^2)	:	0.006 694 380
Flattening ($1/f$)	:	298.257 223 563

4.2 PROJECTION

Projection	:	Universal Transverse Mercator
AMG Zone	:	55
Central Meridian (C.M.)	:	147° East
Scale factor on the C.M.	:	0.9996
False Easting	:	500 000m
False Northing	:	10 000 000m
Latitude of Origin	:	0° (Equator)
Unit of Measure	:	International Metre

4.3 DATUM TRANSFORMATION

The following 7-parameter datum transformation was used to convert WGS 84 co-ordinates to AGD 66 co-ordinates:

Dx	=	+123.314m
Dy	=	+ 47.223m
Dz	=	- 136.594m
Rx	=	+ 0.264"
Ry	=	+ 0.322"
Rz	=	+ 0.270"
Scale (K)	=	+ 1.384

Note: The sign conventions used in Racal software in the datum transformations were derived as follows:

GNS Survey Software:

The convention applied is that used by the US Department of Defence and by Higgins (Transformation from WGS 84 to AGD 66 - An interim solution), where a positive rotation about the Z axis is anti-clockwise movement of the X and Y axes (when viewed from the North Pole looking towards the centre of the Earth).

These values were adopted by the Inter-Governmental Advisory Committee on Surveying and Mapping Standards for Control Surveys in May 1990.

4.4 GEOID SPHEROID SEPARATION

The Geoid Spheroid (WGS 84) Separation (N) at the Baleen-2 location is +6.752 metres. This is derived from the OSU91A model.

5. EQUIPMENT CHECKS AND CALIBRATIONS

5.1 CHECK FIX AT BARRAMUNDI-1

A Differential GPS check fix at the Barramundi-1 location was computed using SkyFix/SkyFix Spot Differential GPS. Between 2145 and 2152 on 5 October 1999, 50 sample positions taken at 10 second intervals were observed.

The published co-ordinates of Barramundi-1 are as follows:

Datum: AGD 66

Latitude : 39° 39' 42.01" South
Longitude : 145° 44' 02.87" East

Projection: AMG Zone 55 C.M. 147° East

Easting : 391 413.9m
Northing : 5 609 012.8m

The computed Differential GPS check fix co-ordinates of the drillstem was as follows:

Datum: AGD 66

Latitude : 39° 39' 41.930" South
Longitude : 145° 44' 02.912" East

Projection: AMG Zone 55 C.M. 147° East

Easting : 391 413.29m
Northing : 5 609 014.59m

The Differential GPS check fix co-ordinates of the drillstem is 1.89 metres on a bearing of 342.1° (T) from the published co-ordinates of the Barramundi-1 location.

5.2 GYRO CALIBRATION

The S.G. Brown 1000S survey gyro installed on the Sedco 702 was calibrated at 1755 on 6 October 1999 at the Barramundi-2 location. The calibration was performed by observing the angle from the centreline of the Sedco 702 to the sun, using a marine sextant, to determine the Calculated Heading (C). The Observed (O) gyro reading was recorded simultaneously. A correction (C-O) of -0.41° was calculated and entered into the navigation computer.

See Appendix E for the Gyro Calibration Observations.

6. GLOBAL POSITIONING SYSTEM (GPS)

6.1 SYSTEM DESCRIPTION

The NAVSTAR GPS (Navigational Satellite Timing and Ranging Global Positioning System) is an USA Military all weather, space-based positioning system that transmits signals from a constellation of satellites orbiting the Earth. It is capable of providing suitably equipped users world-wide with accurate three dimensional positions on, or near, the Earth's surface. The accuracy of these determined positions can vary from a few millimetres to 100 metres depending on the method of data acquisition and processing. System design consists of three integrated parts: the Ground Control Segment, the Space Segment and the User Segment.

The operational space segment consists of 24 production satellites and 3 active spares; the term Space Vehicle (SV) is used as a synonym for satellite. The satellites are in high orbits, at approximately 20,200km, having an orbit period of 12 hours. They are arranged in 6 orbital planes, inclined at 55 degrees with near circular orbits. The configuration provides complete 4 satellite (3D) coverage world-wide.

6.2 GPS OBSERVATIONS

There are two important types of GPS observations (observables):

Pseudo-range and Carrier phase.

Carrier phase is sometimes also referred to as carrier beat phase. Pseudo-range techniques are generally used for navigation e.g. Racal's MultiFix. In high-precision baseline surveying the carrier phase is used. Although the (undifferenced) phase can be used directly, it has become common practice, at least in surveying applications, to process certain linear combinations of the original carrier phase observations (double differences and triple differences).

Pseudo-ranges

The Pseudo-range is a measure of the distance between the satellite and the receiver at the epochs of transmission and reception of the signals. The transit time of the signals is measured by comparing (correlating) identical pseudo-random noise (PRN) codes generated by the satellite and by the receiver. A code-tracking loop within the receiver shifts the internal replica of the PRN code in time until maximum correlation occurs. The codes generated at the receiver are derived from the receiver's own clock, and the codes of the satellite transmissions are generated by the satellite system of clocks. It follows that unavoidable timing errors in both the satellite and the receiver clock will cause the measured quantity (Pseudo-range) to differ from the geometric distance.

In offshore applications, where instantaneous positions are required, Pseudo-range is the preferred observable. Given the satellite ephemeris (i.e. the position of the satellite at the epoch of transmission), there are seven unknowns: two clock errors, three receiver co-ordinates and the ionospheric and tropospheric delays. The effect of the satellite clock error is negligible for the typical navigation solution, particularly considering that the time errors are indistinguishable from the ionospheric and tropospheric delays. The satellite clocks are constantly monitored and synchronised with GPS time as maintained by the control centre. Actual offsets of the satellite clocks are approximated by polynomials in time and transmitted as part of the navigation message to the user for the correction of the measured Pseudo-ranges. The ionospheric and tropospheric delays can be computed on the basis of ionospheric and tropospheric models, thus there are four unknowns left X, Y, Z and receiver clock error. These can be determined from four Pseudo-ranges measured simultaneously to four GPS satellites.

Carrier Phase

The phase observable is the difference between the phase of the carrier signal of the satellite, measured at the receiver, and the phase of the local oscillator within the receiver at the epoch of measurement. This can be regarded as a biased range measurement of the satellite-receiver distance with the integer number of carrier waves being unknown. The wavelength of the L1 carrier is about 19cm. Because of the fraction of the carrier phase is measured, the term "interferometry" is often used to describe carrier phase techniques.

6.3 DIFFERENTIAL GPS (DGPS)

As the GPS is primarily a USA Defence system, the navigation accuracy to the civil user is degraded to about 100 metres standard deviation (Standard Position Service -SPS), as specified in the USA 1990 Federal Radio Navigation Plan. The means by which the USA Military degrade GPS is with the use of Selective Availability (SA) to control the accuracy of Pseudo-range measurements. Essentially, the user is given a false Pseudo-range for each satellite so that the resulting measurement is in error by a controlled amount.

Differential GPS is a means by which the civil user can overcome Selective Availability. It requires a receiver be located at a precisely known point from which Pseudo-range corrections for each satellite can be determined and monitored. These Pseudo-range corrections are then communicated by means of a telecommunications link to users at unknown locations. The Differential GPS technique has proven to be particularly effective and can improve the accuracy figure to 5 metres or better with or without Selective Availability activated. In the relative mode, most of the important systematic errors common to the known station and at the unknown location cancel out to improve the accuracy of the computed position.

6.4 SKYFIX/SKYFIX SPOT DIFFERENTIAL LINK

Racal Survey Australia Limited introduced its SkyFix Differential GPS System in Australia in February 1991, using the Inmarsat Pacific and Indian Ocean marine communications satellites as the differential data broadcast link. Extensive performance trials and projects undertaken to date have shown SkyFix to meet the best industry expectations in terms of quality of service and accuracy.

Satellite communications systems, particularly at the Inmarsat L-band frequencies of 1.5 GHz are reliable and free of the interference associated with the crowded MF/HF bands. This high data integrity gives users confidence that the corrections will be continuously received without interference.

The SkyFix Australian network comprises of reference stations at Dampier, Broome, Perth, Adelaide, Melbourne, Sydney, Cairns and Darwin.

The SkyFix Spot Differential GPS System was launched in Australia in October 1994, using the OPTUS high powered focused communications satellite as the differential data broadcast link. Extensive performance trials and projects undertaken to date have shown SkyFix Spot to meet the industry expectations in terms of quality of service and accuracy.

The SkyFix Spot system has a link capacity of 1200 bits per second, similar to the SkyFix system but because it is only transmitting corrections from the Australian network an update rate of better than five seconds is achieved.

The OPTUS satellite uses the L-band frequencies of 1.5586 GHz which are very reliable and free of interference avoiding data loss associated with the crowded MF/HF bands.

The SkyFix Spot network comprises of reference stations at Dampier, Broome, Perth, Adelaide, Melbourne, Cairns, Darwin and also Ujung Pandang and Jakarta in Indonesia, and Auckland, New Zealand.

The differential corrections generated at each reference station are brought via landline links, to the data hub and control centre in Singapore; where the system is monitored for performance and quality. From there, a composite message containing full RTCM 104 version 2 formatted data from all reference stations is sent via dual redundant links to Satellite Earth Stations at Sentosa Island, Singapore, O.T.C. Perth, and the earth station at Lockridge, Perth, Western Australia, for uplink and broadcast over the Inmarsat Pacific and Indian Ocean Region satellites and OPTUS satellite.

The SkyFix/SkyFix Spot system includes a 24 hour monitoring facility to ensure the validity of data received at the control centre from the Differential GPS reference stations, and that the same data are received over the SkyFix/SkyFix Spot satellite data links.

6.5 TRIMBLE SERIES 4000 GPS RECEIVER

The Trimble Series 4000 GPS receiver is designed for moderate precision static and dynamic positioning applications. The GPS receiver provides time and three-dimensional station co-ordinates at a once-per-second update rate.

The receiver receives the civilian coded signal (C/A) from the GPS NAVSTAR satellites. The receiver automatically acquires and simultaneously tracks GPS satellites and precisely measures carrier and code phase and computes position and velocity.

Latitude, longitude and height values are output on the World Geodetic System (WGS 84) Earth-centred, Earth-fixed co-ordinate system.

The receiver is designed to measure the following observables:

- Coarse/Acquisition (C/A) code Pseudo-ranges
- Rate of change of Pseudo-range
- Integrated Carrier

C/A code correlation techniques measure the propagation time of the signal from the satellite to the antenna. Latitude, longitude, height and time can be determined from measurements made from at least 4 satellites, by a process similar to triangulation.

To determine speed and heading, the receiver calculates the rate of change of Range (the range-rate) by measuring the Doppler shift of the carrier.

It is capable of receiving and processing differential corrections from other reference sources using the standard format of the Radio Technical Commission for Maritime Services, Special Committee 104 (RTCM sc.-104), Version 1.0 or 2.0 protocols.

The Trimble Series 4000 GPS Receiver has several options available, including internal data logging memory, event marker logging etc. and therefore may be used alone or as part of a more extensive navigation system.

6.6 MULTIFIX II

System Overview

MultiFix 2 is a differential GPS program, designed to give the user a positioning system incorporating the control features essential for analysis of quality of real time data.

The program can use Differential GPS corrections calculated at up to 15 reference stations onshore and transmitted to the Cultuse user, either on or offshore, via the Inmarsat/OPTUS satellites or radio link. The received data is filtered and assessed as to its quality before being used in the computation of the solutions. Statistics employed are based upon UKOOA recommendations.

Up to six independent positioning solutions can be calculated, each one using data from up to 15 differential reference stations. Computed positions formed by any one of these solutions can be output to external navigation systems, giving the user a positioning system with inbuilt quality control. Before data is output, quality indicators for each solution are computed and may be included depending on selected data format.

The software is designed to work as a stand-alone system, and also in conjunction with software packages such as GNS, Racal's rig move, surveying, and seismic application software.

Quality Control Features

- MultiFix assess the validity of incoming differential correction data, sent as an RTCM-104 Messages.
- The incoming corrections and other observables are filtered.
- Differential corrections are used to compute up to six solutions.
- Each solution can be based on data from different combinations of differential reference stations, using different satellite constellations, to avoid reliance on one particular set up.
- Integrity checks are performed on received and computed data, with an issue of warnings as appropriate.
- Raw and computed data can be logged for analysis and replay.
- MultiFix outputs any of the solution positions it computes, along with its associated QC information.
- Statistical measures for internal and external reliability are based on UKOOA recommendations:
 - W-Test for outliers carried out for each position fix.
 - F-Test for unit variance carried out for each position fix.
 - When no more outliers are identified in any fix, precision and reliability measures will be calculated:
 - Precision: a posteriori error ellipse;
 - Reliability: external reliability (positional MDE using a power of test of 80%).

Position Control

Geodetic Data

The required geodetic parameters are entered for the datum and spheroid. The default data is for WGS-84.

DGPS Links

a. Reference Stations

The name and ident number of all differential correction reference stations are input. The reference stations used on this project were:- Darwin, Dampier, Broome, Perth.

b. Differential Links

- Various Links can be selected, with the Link Name and Link ID entered
- Reference stations to be used (from those set up under 'Reference Stations') can then be selected
- The data format can also be selected

Solution Set Up

The user can edit to select the type of data (RAW DATA or POSITION) to be used from the receiver, and whether height aiding in ON or OFF for each solution. If selected as OFF, then the positioning mode for that a solution will be 3D. On this project, height aiding was selected, with a manually entered standard deviation for the height of 5m.

- **Trimble Direct Injection Position**

It is possible to include a Trimble direct injection differential positions as one of the solutions.

Ref. Stns for Solution

For each solution the stations and links are defined.

To achieve this the user enters for each solution the link to be used and the reference station names. Up to eight stations can be included in each solution.

On this project the solutions for SkyFix Spot and SkyFix differential links were set up as follows:-

1. SkyFix: Melbourne, Sydney, Adelaide, Wellington
SkyFix Spot: Melbourne, Adelaide, Cairns, Wellington
2. SkyFix: Melbourne, Sydney, Adelaide
SkyFix Spot: Melbourne, Adelaide, Cairns
3. SkyFix: Melbourne, Sydney
SkyFix Spot: Melbourne, Adelaide
4. SkyFix: Melbourne
SkyFix Spot: Melbourne
5. SkyFix: Sydney
SkyFix Spot: Adelaide
6. GPS (Stand Alone)

Solution 1 using the SkyFix and SkyFix Spot links was selected as the accepted solution.

GPS Weighting Parameters

This option sets the weighting parameters for all of the solutions to be used. The default values, as below, are considered optimum.

- Elevation Mask (°) 10
- Elevation Delta (°) 5
- Tropo Correlation Distance (km) 50
- Iono Correlation Distance (km) 1000
- 2892 Ephem Correlation Distance (km) 20000
- SA Acceleration SD (m/s²) .008

Note: For the final fix of position, the elevation mask was set as 10°

QC Parameters

In this option the Quality Control parameters for all the solutions are set. The figures in yellow can be changed, and those in dark cyan cannot be changed, such as the criteria for the F-Test and W-Test.

- **Solution Rejection Criteria**

These can be set to ON or OFF dependant on whether the user wants the solutions to be stopped when cut off levels have been reached.

- **Positioning QC Thresholds**

Here the cut off levels for various values, as used in conjunction with the Solution Rejection Criteria are entered. If the rejection criteria is switched off, then the values on line will be displayed as red to indicate that these levels have been reached and passed.

- **Filter QC**

This section controls the code carrier filter. The pseudo-range SD is dependant on the type of GPS receiver being used. Each type generates a specific amount of internal noise, which the filter must recognise in order to function properly. The values to be entered for each GPS receiver type are as follows:

Trimble 4000 series DL	4m
Trimble 4000 series DLII	3m
Trimble 4000 series DS	1m
Trimble 4000 series SSE	0.5m

Event Control

Logging

From this option, the logging can be switched on or off.

This option decides the default state of logging when going on-line for the first time, or after a power failure. If ON is selected, then the logging is automatically initiated when going on-line. If OFF is selected then logging is defaulted to OFF when going on-line.

The Log Path displayed on this screen is selectable from the System Configuration, Location of Files option. The path can be altered so that, for example, data logged for seismic lines can be logged to different directories.

A message will be displayed when the hard disk is full and logging has been disabled.

Data Output to Digiboard Ports

Data can either be output in DeltaNav format, DeltaNav QC format, NMEA 0183 GPGGA format, NMEA 0183 GPGLL format or Racal UKOOA format. The default format is Racal UKOOA format.

Monitoring of Data

Two fundamental types of monitoring quality control are available in the software. They are as follows:

- **Code Carrier Filter**
 This facility checks on the quality of incoming pseudo-ranges, comparing what is seen coming in to what would be expected, in order to derive the amount of noise on the signal due to, for example, multipath, the GPS receivers interval noise, or the delay caused by ionospheric refraction.
- **A Priori and A Posteriori Statistics**
 The A Priori values are calculated before computation of a solution and are based on satellite geometry and predicted measurement accuracy.

The A Posteriori values are calculated once the solution has been computed, and are based upon residuals of the solution.

The A Priori values give a measure of the theoretical accuracy of the solution, as modelled by the Users QC weighting criteria. The A Posteriori results are calculated from the incoming data and are a measure of any errors or noise not taken into account in the modelling. Taken together these two sets of results can indicate the quality of the solution.

Any excessive noise can be detected via the filter graphs. The 2D and 3D error graphs will indicate how good the position was expected to be and how good it was seen to be. The error rising as the quality falls. The unit variance will then indicate how well the data compared with the model and what trend it is following.

Identification of Problems

Problems with the quality can be identified within the program, using two main graphical displays:

- Code Carrier Filter graphs
- A Priori and A Posteriori graphs

Code Carrier

There are two fundamental observables obtained from a GPS receiver, the code and the carrier. The code, or pseudo-range, is derived from the time required to match up the incoming code from the satellite with the code in the receiver. The carrier is the signal this code is modulated onto. If the signal suffers from multipath then the code and carrier are affected in opposite directions. The code carrier filter within the program detects these conditions by continually subtracting one from the other, the divergence indicating multipath.

The filter graphs will indicate any cycle slips that have occurred and display the state of the raw data coming in. The filter places a value on the amount of multipath it observes in the data it receives. If this value fluctuates wildly or stays at a persistently high level it may be that the GPS antenna in use is situated in an area prone to multipath and should be moved.

The filter also assesses the amount of ionospheric delay it observes on the incoming data and places a value on this, displaying the value graphically.

A Priori and A Posteriori QC Measures

A Priori statistics are a measure of expected position accuracy given current satellite geometry and model weighting criteria.

For example, the 2D and 3D error graphs indicate what level of precision is to be expected from the position computed given the present satellite geometry.

The A Posteriori values are a measure of the position quality actually achieved using the received data. For example, the RMS value indicates how well or otherwise the position lines closed - an observed rather than predicted value.

Marginal Detectable Error

The user must note that a large MDE does not necessarily reflect bad observations, it merely informs the user that internal reliability of the process is not good for that observation. The MDE Value is the smallest bias that can be detected by the test with an 80% probability.

7. SAFETY

Racal Personnel attended a rig induction at 1440 on 4 October 1999 and a safety briefing on the Sedco 702 at 1900 on 10 October 1999.

Racal Personnel attended all muster drills which were conducted.

Racal Personnel acted at all times in accordance with the statutory and company guidelines. No unsafe incidents occurred during the duration of this project.

8. PERSONNEL AND EQUIPMENT

8.1 PERSONNEL

The following personnel were employed on this project:

FOR: RACAL SURVEY AUSTRALIA LIMITED

Mr Troy Langley : Surveyor
Mr Chris Hakkennes : Engineer

FOR: CULTUS PETROLEUM NL

Mr Bill Edmonds : Client Representative

8.2 EQUIPMENT

The following equipment was used on this project:

Item

DGPS System

2 x Trimble 4000DS GPS Receivers
c/w Antennae, power supplies, cables etc.
1 x SkyFix Rig Portable
1 x SkyFix Rotator Controller
2 x Downconverters
3 x SkyFix Spot/SkyFix Receivers
2 x SkyFix Spot Whip Antennae

Computing System

2 x Compaq Pentiums 2
1 x Compaq Portable 486/66
2 x Epson LX 800 Printers

Gyro

1 x SG Brown Gyro
c/w Gyro PSU

Miscellaneous

5 x 24v Power Supply Units
c/w Power Stabiliser

9. DISTRIBUTION

Copies of this report are distributed as follows:

Cultus Petroleum NL
Attn: Mr Chris Way

: 1 preliminary copy
: 3 final copies

Racal Survey Australia Limited

: 1 copy



Troy Langley
Surveyor

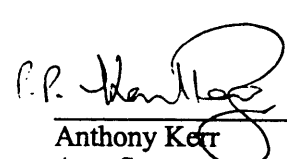

Anthony Kerr
Area Surveyor

APPENDIX A

OFFSET DIAGRAM - SEDCO 702

SEDCO 702 - OFFSET DIAGRAM

(NOT TO SCALE)

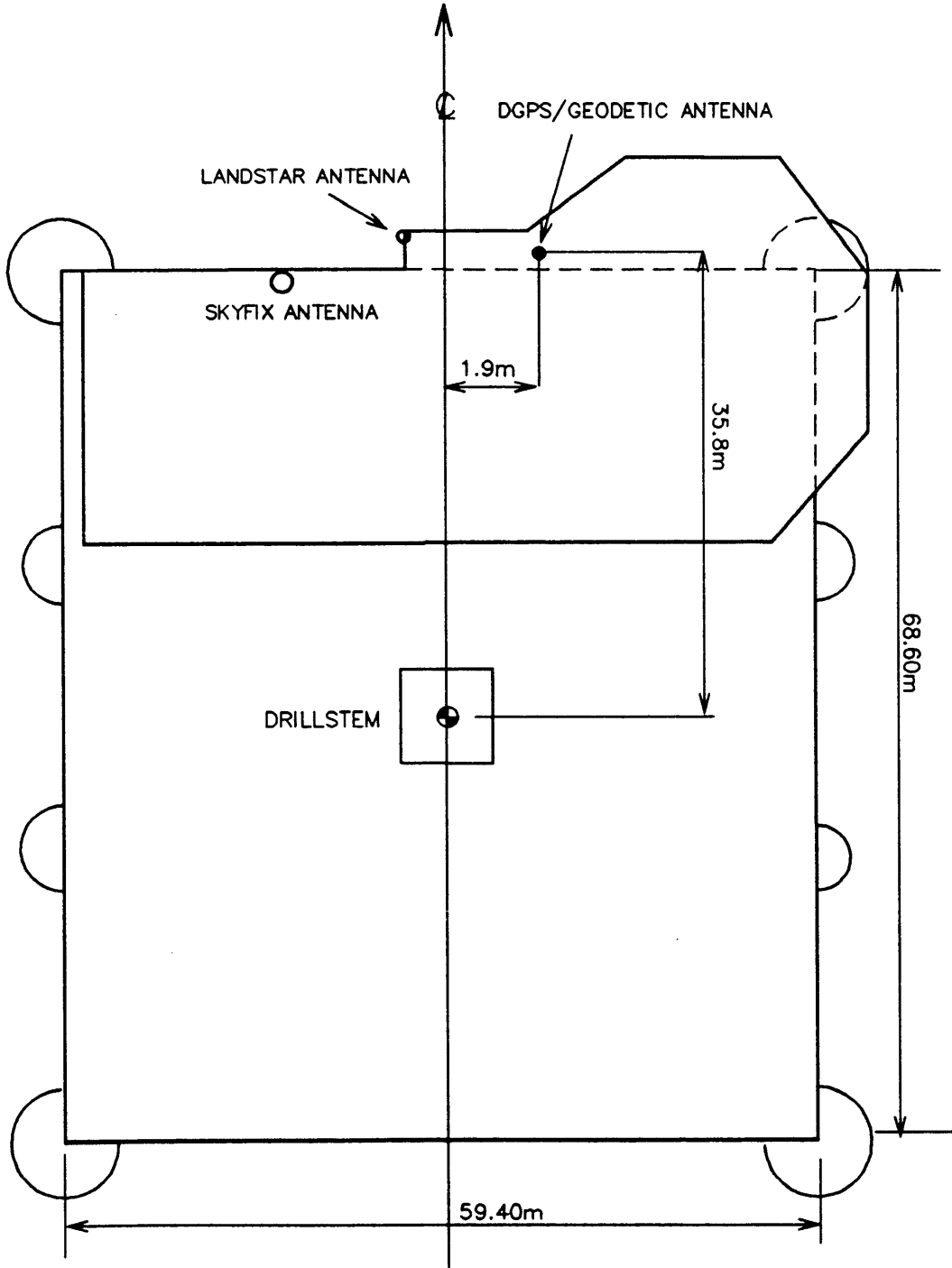

APPENDIX B

DIFFERENTIAL GPS FINAL FIX PRINTOUTS



Racal Survey Group Ltd

FINAL POSITION FIX – DIFFERENTIAL GPS

Job: Survey
 Job Number: 2930A3
 Racal Surveyor: Troy Langley
 Client: Cultus Petroleum
 Client Representative: R.Kahut

Sampling started: 11 Oct 1999 01:58:00
 Sampling end: 11 Oct 1999 02:39:28

Sedco 702**Intended datum location**

Datum: AGD66
 Latitude: 38°01'55.787"S Longitude: 148°24'37.574"E
 Projection: AMG Zone 55
 Easting: 623782.00 Northing: 5789663.00

Final Antenna Position (R1 Racal UKOOA):

Sample size: 249 fixes used out of a total of 250.

Antenna offset

X: 1.90m Y: 35.80m Z: 0.00m
 Range: 35.85m Rel Brg from datum to antenna: 3.0°

Datum: WGS 84
 Latitude: 38°01'51.254"S Longitude: 148°24'41.369"E Spheroidal Ht: 28.31m
 Datum: AGD66
 Latitude: 38°01'56.779"S Longitude: 148°24'36.845"E Spheroidal Ht: 35.29m
 Projection: AMG Zone 55
 Easting: 623763.77 Northing: 5789632.69 Spheroidal Ht: 35.29m

Standard deviations

Long or E: 0.31m
 Lat or N: 0.26m
 Height: 0.79m
 Position: 0.41m

Final Datum Position

Datum: AGD66
 Latitude: 38°01'55.758"S Longitude: 148°24'37.549"E Spheroidal Ht: 35.29m
 Projection: AMG Zone 55
 Easting: 623781.41 Northing: 5789663.90 Spheroidal Ht: 35.29m

Mean corrected heading: 206.4°T
 SD heading: 0.0°T
 Intended heading: 210.0°T
 Difference from intended: -3.6°

Final Datum Position is 1.08m on a bearing of 326.0°T (326.9°G) from the intended location.

Raw Data

Sedco 702

Position Data

Antenna (R1 Racal UKOOA):

Datum: WGS 84

<u>Time</u>	<u>Latitude</u>	<u>Longitude</u>	<u>Spheroidal Ht</u>	<u>Resid</u>
11-Oct-1999 01:58:23	38°01'51.253"S	148°24'41.384"E	28.60m	0.36m
11-Oct-1999 01:58:30	38°01'51.253"S	148°24'41.390"E	28.60m	0.51m
11-Oct-1999 01:58:40	38°01'51.250"S	148°24'41.374"E	28.40m	0.17m
11-Oct-1999 01:58:50	38°01'51.250"S	148°24'41.383"E	28.60m	0.36m
11-Oct-1999 01:59:00	38°01'51.259"S	148°24'41.387"E	28.30m	0.46m
11-Oct-1999 01:59:10	38°01'51.252"S	148°24'41.374"E	28.00m	0.13m
11-Oct-1999 01:59:20	38°01'51.247"S	148°24'41.371"E	28.60m	0.22m
11-Oct-1999 01:59:30	38°01'51.252"S	148°24'41.386"E	28.10m	0.41m
11-Oct-1999 01:59:40	38°01'51.255"S	148°24'41.381"E	28.30m	0.29m
11-Oct-1999 01:59:50	38°01'51.253"S	148°24'41.369"E	28.30m	0.03m
11-Oct-1999 02:00:00	38°01'51.247"S	148°24'41.371"E	28.30m	0.22m
11-Oct-1999 02:00:10	38°01'51.256"S	148°24'41.378"E	28.40m	0.22m
11-Oct-1999 02:00:20	38°01'51.255"S	148°24'41.375"E	28.30m	0.14m
11-Oct-1999 02:00:30	38°01'51.250"S	148°24'41.375"E	28.60m	0.19m
11-Oct-1999 02:00:40	38°01'51.253"S	148°24'41.372"E	28.70m	0.07m
11-Oct-1999 02:00:50	38°01'51.256"S	148°24'41.381"E	28.20m	0.29m
11-Oct-1999 02:01:00	38°01'51.271"S	148°24'41.384"E	27.60m	0.64m
11-Oct-1999 02:01:10	38°01'51.261"S	148°24'41.365"E	28.90m	0.24m
11-Oct-1999 02:01:20	38°01'51.253"S	148°24'41.362"E	28.90m	0.18m
11-Oct-1999 02:01:30	38°01'51.262"S	148°24'41.354"E	29.10m	0.45m
11-Oct-1999 02:01:40	38°01'51.264"S	148°24'41.357"E	29.70m	0.43m
11-Oct-1999 02:01:50	38°01'51.271"S	148°24'41.354"E	29.70m	0.64m
11-Oct-1999 02:02:00	38°01'51.268"S	148°24'41.347"E	29.90m	0.69m
11-Oct-1999 02:02:10	38°01'51.270"S	148°24'41.350"E	29.40m	0.68m
11-Oct-1999 02:02:20	38°01'51.271"S	148°24'41.348"E	29.50m	0.74m
11-Oct-1999 02:02:30	38°01'51.265"S	148°24'41.353"E	29.50m	0.52m
11-Oct-1999 02:02:40	38°01'51.264"S	148°24'41.348"E	29.20m	0.60m
11-Oct-1999 02:02:50	38°01'51.262"S	148°24'41.350"E	29.70m	0.53m
11-Oct-1999 02:03:00	38°01'51.265"S	148°24'41.350"E	29.70m	0.58m
11-Oct-1999 02:03:10	38°01'51.265"S	148°24'41.347"E	30.00m	0.64m
11-Oct-1999 02:03:20	38°01'51.262"S	148°24'41.344"E	29.60m	0.66m
11-Oct-1999 02:03:30	38°01'51.259"S	148°24'41.347"E	29.80m	0.56m
11-Oct-1999 02:03:40	38°01'51.264"S	148°24'41.362"E	29.10m	0.36m
11-Oct-1999 02:03:50	38°01'51.270"S	148°24'41.356"E	29.10m	0.59m
11-Oct-1999 02:04:00	38°01'51.265"S	148°24'41.354"E	29.20m	0.50m
11-Oct-1999 02:04:10	38°01'51.259"S	148°24'41.357"E	28.90m	0.34m
11-Oct-1999 02:04:20	38°01'51.262"S	148°24'41.362"E	28.70m	0.30m
11-Oct-1999 02:04:30	38°01'51.265"S	148°24'41.365"E	29.00m	0.36m
11-Oct-1999 02:04:40	38°01'51.262"S	148°24'41.357"E	29.20m	0.39m
11-Oct-1999 02:04:50	38°01'51.268"S	148°24'41.363"E	28.90m	0.46m
11-Oct-1999 02:05:00	38°01'51.264"S	148°24'41.371"E	28.50m	0.31m
11-Oct-1999 02:05:10	38°01'51.270"S	148°24'41.365"E	29.20m	0.50m
11-Oct-1999 02:05:20	38°01'51.265"S	148°24'41.368"E	28.80m	0.34m
11-Oct-1999 02:05:30	38°01'51.267"S	148°24'41.371"E	28.60m	0.40m
11-Oct-1999 02:05:40	38°01'51.268"S	148°24'41.369"E	29.00m	0.43m
11-Oct-1999 02:05:50	38°01'51.274"S	148°24'41.366"E	29.30m	0.62m
11-Oct-1999 02:06:00	38°01'51.267"S	148°24'41.374"E	29.20m	0.42m

11-Oct-1999 02:06:10 38°01'51.267"S148°24'41.368"E	29.50m	0.40m
11-Oct-1999 02:06:20 38°01'51.267"S148°24'41.366"E	29.30m	0.41m
11-Oct-1999 02:06:30 38°01'51.265"S148°24'41.375"E	29.20m	0.37m
11-Oct-1999 02:06:40 38°01'51.270"S148°24'41.381"E	29.80m	0.57m
11-Oct-1999 02:06:50 38°01'51.268"S148°24'41.377"E	29.30m	0.47m
11-Oct-1999 02:07:00 38°01'51.276"S148°24'41.380"E	29.40m	0.73m
11-Oct-1999 02:07:10 38°01'51.274"S148°24'41.384"E	29.20m	0.71m
11-Oct-1999 02:07:20 38°01'51.268"S148°24'41.374"E	29.40m	0.45m
11-Oct-1999 02:07:30 38°01'51.271"S148°24'41.380"E	29.30m	0.59m
11-Oct-1999 02:07:40 38°01'51.276"S148°24'41.387"E	29.50m	0.80m
11-Oct-1999 02:07:50 38°01'51.274"S148°24'41.386"E	29.50m	0.74m
11-Oct-1999 02:08:00 38°01'51.273"S148°24'41.381"E	29.20m	0.65m
11-Oct-1999 02:08:10 38°01'51.259"S148°24'41.375"E	29.20m	0.21m
11-Oct-1999 02:08:20 38°01'51.258"S148°24'41.383"E	28.90m	0.36m
11-Oct-1999 02:08:30 38°01'51.255"S148°24'41.387"E	28.50m	0.43m
11-Oct-1999 02:08:40 38°01'51.250"S148°24'41.378"E	28.20m	0.25m
11-Oct-1999 02:08:50 38°01'51.253"S148°24'41.381"E	28.20m	0.29m
11-Oct-1999 02:09:00 38°01'51.243"S148°24'41.383"E	28.30m	0.48m
11-Oct-1999 02:09:10 38°01'51.234"S148°24'41.377"E	28.00m	0.64m
11-Oct-1999 02:09:20 38°01'51.228"S148°24'41.375"E	28.00m	0.81m
11-Oct-1999 02:09:30 38°01'51.232"S148°24'41.368"E	27.80m	0.68m
11-Oct-1999 02:09:40 38°01'51.231"S148°24'41.375"E	27.70m	0.72m
11-Oct-1999 02:09:50 38°01'51.231"S148°24'41.377"E	27.70m	0.73m
11-Oct-1999 02:10:00 38°01'51.235"S148°24'41.366"E	27.70m	0.59m
11-Oct-1999 02:10:20 38°01'51.228"S148°24'41.363"E	27.90m	0.82m
11-Oct-1999 02:10:30 38°01'51.232"S148°24'41.362"E	27.80m	0.70m
11-Oct-1999 02:10:40 38°01'51.231"S148°24'41.368"E	27.60m	0.71m
11-Oct-1999 02:10:50 38°01'51.243"S148°24'41.351"E	28.10m	0.56m
11-Oct-1999 02:11:00 38°01'51.244"S148°24'41.365"E	27.90m	0.33m
11-Oct-1999 02:11:10 38°01'51.240"S148°24'41.368"E	27.90m	0.43m
11-Oct-1999 02:11:20 38°01'51.240"S148°24'41.365"E	27.80m	0.44m
11-Oct-1999 02:11:30 38°01'51.252"S148°24'41.366"E	27.60m	0.10m
11-Oct-1999 02:11:40 38°01'51.246"S148°24'41.366"E	28.00m	0.26m
11-Oct-1999 02:11:50 38°01'51.246"S148°24'41.365"E	27.90m	0.27m
11-Oct-1999 02:12:00 38°01'51.246"S148°24'41.366"E	27.80m	0.26m
11-Oct-1999 02:12:10 38°01'51.247"S148°24'41.369"E	27.80m	0.22m
11-Oct-1999 02:12:20 38°01'51.250"S148°24'41.368"E	27.90m	0.13m
11-Oct-1999 02:12:30 38°01'51.259"S148°24'41.374"E	27.70m	0.19m
11-Oct-1999 02:12:40 38°01'51.250"S148°24'41.371"E	27.70m	0.13m
11-Oct-1999 02:12:50 38°01'51.256"S148°24'41.384"E	27.70m	0.36m
11-Oct-1999 02:13:00 38°01'51.259"S148°24'41.381"E	28.00m	0.33m
11-Oct-1999 02:13:10 38°01'51.250"S148°24'41.375"E	27.80m	0.19m
11-Oct-1999 02:13:20 38°01'51.252"S148°24'41.387"E	27.80m	0.44m
11-Oct-1999 02:13:30 38°01'51.253"S148°24'41.381"E	27.70m	0.29m
11-Oct-1999 02:13:40 38°01'51.250"S148°24'41.374"E	28.10m	0.17m
11-Oct-1999 02:13:50 38°01'51.249"S148°24'41.383"E	28.10m	0.37m
11-Oct-1999 02:14:00 38°01'51.252"S148°24'41.387"E	28.10m	0.44m
11-Oct-1999 02:14:10 38°01'51.255"S148°24'41.381"E	27.90m	0.29m
11-Oct-1999 02:14:20 38°01'51.255"S148°24'41.390"E	28.00m	0.51m
11-Oct-1999 02:14:30 38°01'51.261"S148°24'41.383"E	28.10m	0.40m
11-Oct-1999 02:14:40 38°01'51.262"S148°24'41.390"E	27.50m	0.56m
11-Oct-1999 02:14:50 38°01'51.253"S148°24'41.381"E	27.90m	0.29m
11-Oct-1999 02:15:00 38°01'51.256"S148°24'41.386"E	27.90m	0.41m
11-Oct-1999 02:15:10 38°01'51.255"S148°24'41.375"E	27.70m	0.14m
11-Oct-1999 02:15:20 38°01'51.255"S148°24'41.378"E	27.90m	0.22m
11-Oct-1999 02:15:30 38°01'51.259"S148°24'41.381"E	27.90m	0.33m
11-Oct-1999 02:15:40 38°01'51.259"S148°24'41.383"E	28.00m	0.37m
11-Oct-1999 02:15:50 38°01'51.259"S148°24'41.374"E	27.80m	0.19m
11-Oct-1999 02:16:00 38°01'51.265"S148°24'41.378"E	27.70m	0.40m
11-Oct-1999 02:16:10 38°01'51.276"S148°24'41.377"E	27.60m	0.70m
11-Oct-1999 02:16:20 38°01'51.270"S148°24'41.387"E	27.40m	0.66m
11-Oct-1999 02:16:30 38°01'51.268"S148°24'41.383"E	28.00m	0.55m

11-Oct-1999 02:16:40 38°01'51.265"S148°24'41.377"E	28.00m	0.39m
11-Oct-1999 02:16:50 38°01'51.262"S148°24'41.381"E	28.10m	0.38m
11-Oct-1999 02:17:00 38°01'51.267"S148°24'41.380"E	28.20m	0.48m
11-Oct-1999 02:17:10 38°01'51.261"S148°24'41.378"E	28.30m	0.30m
11-Oct-1999 02:17:20 38°01'51.259"S148°24'41.384"E	28.40m	0.39m
11-Oct-1999 02:17:30 38°01'51.258"S148°24'41.381"E	28.40m	0.31m
11-Oct-1999 02:17:40 38°01'51.258"S148°24'41.384"E	28.20m	0.38m
11-Oct-1999 02:17:50 38°01'51.265"S148°24'41.384"E	28.60m	0.49m
11-Oct-1999 02:18:00 38°01'51.252"S148°24'41.380"E	28.50m	0.27m
11-Oct-1999 02:18:10 38°01'51.262"S148°24'41.381"E	28.10m	0.38m
11-Oct-1999 02:18:20 38°01'51.250"S148°24'41.384"E	28.10m	0.38m
11-Oct-1999 02:18:30 38°01'51.240"S148°24'41.380"E	28.00m	0.50m
11-Oct-1999 02:18:40 38°01'51.244"S148°24'41.378"E	28.00m	0.37m
11-Oct-1999 02:18:50 38°01'51.241"S148°24'41.377"E	27.80m	0.44m
11-Oct-1999 02:19:00 38°01'51.250"S148°24'41.384"E	27.60m	0.38m
11-Oct-1999 02:19:10 38°01'51.249"S148°24'41.378"E	27.70m	0.26m
11-Oct-1999 02:19:20 38°01'51.255"S148°24'41.380"E	27.50m	0.26m
11-Oct-1999 02:19:30 38°01'51.255"S148°24'41.378"E	27.60m	0.22m
11-Oct-1999 02:19:40 38°01'51.253"S148°24'41.378"E	27.30m	0.22m
11-Oct-1999 02:19:50 38°01'51.259"S148°24'41.371"E	27.90m	0.16m
11-Oct-1999 02:20:00 38°01'51.253"S148°24'41.374"E	27.80m	0.12m
11-Oct-1999 02:20:10 38°01'51.262"S148°24'41.371"E	27.80m	0.25m
11-Oct-1999 02:20:20 38°01'51.256"S148°24'41.378"E	27.80m	0.22m
11-Oct-1999 02:20:30 38°01'51.256"S148°24'41.375"E	28.00m	0.15m
11-Oct-1999 02:20:40 38°01'51.256"S148°24'41.362"E	28.00m	0.19m
11-Oct-1999 02:20:50 38°01'51.255"S148°24'41.368"E	28.00m	0.04m
11-Oct-1999 02:21:00 38°01'51.262"S148°24'41.366"E	28.30m	0.26m
11-Oct-1999 02:21:10 38°01'51.262"S148°24'41.360"E	28.30m	0.33m
11-Oct-1999 02:21:20 38°01'51.262"S148°24'41.356"E	28.70m	0.41m
11-Oct-1999 02:21:30 38°01'51.268"S148°24'41.365"E	28.70m	0.44m
11-Oct-1999 02:21:40 38°01'51.267"S148°24'41.351"E	28.90m	0.60m
11-Oct-1999 02:21:50 38°01'51.265"S148°24'41.359"E	28.90m	0.42m
11-Oct-1999 02:22:00 38°01'51.268"S148°24'41.360"E	29.30m	0.49m
11-Oct-1999 02:22:10 38°01'51.267"S148°24'41.360"E	29.40m	0.46m
11-Oct-1999 02:22:20 38°01'51.271"S148°24'41.356"E	29.30m	0.62m
11-Oct-1999 02:22:30 38°01'51.271"S148°24'41.363"E	29.50m	0.55m
11-Oct-1999 02:22:40 38°01'51.264"S148°24'41.362"E	29.30m	0.36m
11-Oct-1999 02:22:50 38°01'51.262"S148°24'41.357"E	29.30m	0.39m
11-Oct-1999 02:23:00 38°01'51.268"S148°24'41.365"E	29.40m	0.44m
11-Oct-1999 02:23:10 38°01'51.264"S148°24'41.372"E	29.60m	0.32m
11-Oct-1999 02:23:20 38°01'51.268"S148°24'41.368"E	29.80m	0.43m
11-Oct-1999 02:23:30 38°01'51.268"S148°24'41.363"E	29.60m	0.46m
11-Oct-1999 02:23:40 38°01'51.264"S148°24'41.369"E	29.50m	0.31m
11-Oct-1999 02:23:50 38°01'51.262"S148°24'41.368"E	29.40m	0.25m
11-Oct-1999 02:24:00 38°01'51.261"S148°24'41.371"E	29.30m	0.22m
11-Oct-1999 02:24:10 38°01'51.259"S148°24'41.372"E	29.20m	0.17m
11-Oct-1999 02:24:20 38°01'51.261"S148°24'41.366"E	28.90m	0.23m
11-Oct-1999 02:24:30 38°01'51.252"S148°24'41.372"E	28.70m	0.09m
11-Oct-1999 02:24:40 38°01'51.262"S148°24'41.371"E	28.70m	0.25m
11-Oct-1999 02:24:50 38°01'51.259"S148°24'41.368"E	28.90m	0.16m
11-Oct-1999 02:25:00 38°01'51.258"S148°24'41.371"E	28.70m	0.13m
11-Oct-1999 02:25:10 38°01'51.256"S148°24'41.362"E	28.30m	0.19m
11-Oct-1999 02:25:20 38°01'51.259"S148°24'41.366"E	28.40m	0.17m
11-Oct-1999 02:25:30 38°01'51.258"S148°24'41.365"E	28.30m	0.16m
11-Oct-1999 02:25:40 38°01'51.256"S148°24'41.359"E	28.30m	0.26m
11-Oct-1999 02:25:50 38°01'51.255"S148°24'41.359"E	27.70m	0.25m
11-Oct-1999 02:26:00 38°01'51.250"S148°24'41.360"E	28.30m	0.26m
11-Oct-1999 02:26:10 38°01'51.249"S148°24'41.354"E	27.60m	0.40m
11-Oct-1999 02:26:20 38°01'51.256"S148°24'41.365"E	27.20m	0.12m
11-Oct-1999 02:26:30 38°01'51.255"S148°24'41.359"E	27.80m	0.25m
11-Oct-1999 02:26:40 38°01'51.252"S148°24'41.351"E	28.00m	0.45m
11-Oct-1999 02:26:50 38°01'51.250"S148°24'41.354"E	28.00m	0.39m

11-Oct-1999 02:27:00 38°01'51.259"S148°24'41.356"E	27.90m	0.36m
11-Oct-1999 02:27:10 38°01'51.244"S148°24'41.344"E	28.00m	0.69m
11-Oct-1999 02:27:20 38°01'51.250"S148°24'41.341"E	28.30m	0.70m
11-Oct-1999 02:27:30 38°01'51.250"S148°24'41.344"E	28.00m	0.63m
11-Oct-1999 02:27:40 38°01'51.249"S148°24'41.344"E	27.70m	0.64m
11-Oct-1999 02:27:50 38°01'51.243"S148°24'41.338"E	27.60m	0.83m
11-Oct-1999 02:28:00 38°01'51.244"S148°24'41.345"E	28.10m	0.67m
11-Oct-1999 02:28:10 38°01'51.247"S148°24'41.348"E	27.80m	0.56m
11-Oct-1999 02:28:20 38°01'51.244"S148°24'41.347"E	27.90m	0.62m
11-Oct-1999 02:28:30 38°01'51.249"S148°24'41.350"E	27.60m	0.49m
11-Oct-1999 02:28:40 38°01'51.244"S148°24'41.350"E	27.90m	0.56m
11-Oct-1999 02:28:50 38°01'51.240"S148°24'41.350"E	28.00m	0.64m
11-Oct-1999 02:29:00 38°01'51.244"S148°24'41.362"E	27.50m	0.36m
11-Oct-1999 02:29:10 38°01'51.250"S148°24'41.363"E	27.50m	0.20m
11-Oct-1999 02:29:20 38°01'51.243"S148°24'41.359"E	27.20m	0.42m
11-Oct-1999 02:29:30 38°01'51.249"S148°24'41.359"E	27.40m	0.29m
11-Oct-1999 02:29:40 38°01'51.246"S148°24'41.366"E	27.10m	0.26m
11-Oct-1999 02:29:50 38°01'51.247"S148°24'41.372"E	27.50m	0.23m
11-Oct-1999 02:30:00 38°01'51.247"S148°24'41.369"E	27.60m	0.22m
11-Oct-1999 02:30:10 38°01'51.252"S148°24'41.368"E	27.70m	0.07m
11-Oct-1999 02:30:20 38°01'51.253"S148°24'41.377"E	27.90m	0.19m
11-Oct-1999 02:30:30 38°01'51.253"S148°24'41.375"E	27.70m	0.14m
11-Oct-1999 02:30:40 38°01'51.247"S148°24'41.372"E	27.90m	0.23m
11-Oct-1999 02:30:50 38°01'51.250"S148°24'41.381"E	27.90m	0.31m
11-Oct-1999 02:31:00 38°01'51.249"S148°24'41.372"E	28.10m	0.17m
11-Oct-1999 02:31:10 38°01'51.252"S148°24'41.363"E	28.10m	0.16m
11-Oct-1999 02:31:20 38°01'51.250"S148°24'41.374"E	28.40m	0.17m
11-Oct-1999 02:31:30 38°01'51.243"S148°24'41.363"E	28.60m	0.37m
11-Oct-1999 02:31:40 38°01'51.246"S148°24'41.362"E	27.90m	0.30m
11-Oct-1999 02:31:50 38°01'51.246"S148°24'41.372"E	28.20m	0.26m
11-Oct-1999 02:32:00 38°01'51.240"S148°24'41.372"E	28.40m	0.44m
11-Oct-1999 02:32:10 38°01'51.250"S148°24'41.363"E	28.50m	0.20m
11-Oct-1999 02:32:20 38°01'51.243"S148°24'41.371"E	28.20m	0.34m
11-Oct-1999 02:32:30 38°01'51.235"S148°24'41.371"E	28.40m	0.59m
11-Oct-1999 02:32:40 38°01'51.243"S148°24'41.368"E	28.60m	0.34m
11-Oct-1999 02:32:50 38°01'51.243"S148°24'41.372"E	28.60m	0.35m
11-Oct-1999 02:33:00 38°01'51.246"S148°24'41.371"E	28.90m	0.25m
11-Oct-1999 02:33:10 38°01'51.241"S148°24'41.368"E	28.80m	0.40m
11-Oct-1999 02:33:20 38°01'51.250"S148°24'41.368"E	29.00m	0.13m
11-Oct-1999 02:33:30 38°01'51.244"S148°24'41.371"E	28.90m	0.31m
11-Oct-1999 02:33:40 38°01'51.246"S148°24'41.368"E	29.00m	0.25m
11-Oct-1999 02:33:50 38°01'51.249"S148°24'41.368"E	29.20m	0.16m
11-Oct-1999 02:34:00 38°01'51.243"S148°24'41.371"E	29.30m	0.34m
11-Oct-1999 02:34:10 38°01'51.244"S148°24'41.371"E	29.60m	0.31m
11-Oct-1999 02:34:20 38°01'51.246"S148°24'41.365"E	29.80m	0.27m
11-Oct-1999 02:34:30 38°01'51.241"S148°24'41.368"E	29.10m	0.40m
11-Oct-1999 02:34:40 38°01'51.240"S148°24'41.366"E	29.10m	0.44m
11-Oct-1999 02:34:50 38°01'51.247"S148°24'41.362"E	29.10m	0.28m
11-Oct-1999 02:35:00 38°01'51.246"S148°24'41.366"E	29.40m	0.26m
11-Oct-1999 02:35:10 38°01'51.250"S148°24'41.368"E	29.30m	0.13m
11-Oct-1999 02:35:20 38°01'51.253"S148°24'41.363"E	29.40m	0.16m
11-Oct-1999 02:35:30 38°01'51.250"S148°24'41.365"E	28.50m	0.16m
11-Oct-1999 02:35:40 38°01'51.243"S148°24'41.369"E	28.60m	0.34m
11-Oct-1999 02:35:50 38°01'51.250"S148°24'41.365"E	28.40m	0.16m
11-Oct-1999 02:36:00 38°01'51.247"S148°24'41.365"E	27.90m	0.24m
11-Oct-1999 02:36:10 38°01'51.247"S148°24'41.368"E	27.90m	0.22m
11-Oct-1999 02:36:20 38°01'51.250"S148°24'41.365"E	27.50m	0.16m
11-Oct-1999 02:36:30 38°01'51.246"S148°24'41.368"E	27.60m	0.25m
11-Oct-1999 02:36:40 38°01'51.252"S148°24'41.369"E	27.30m	0.06m
11-Oct-1999 02:36:50 38°01'51.250"S148°24'41.365"E	27.10m	0.16m
11-Oct-1999 02:37:00 38°01'51.255"S148°24'41.366"E	26.90m	0.09m
11-Oct-1999 02:37:10 38°01'51.247"S148°24'41.372"E	26.80m	0.23m

11-Oct-1999 02:37:20 38°01'51.246"S148°24'41.371"E	26.30m	0.25m
11-Oct-1999 02:37:30 38°01'51.243"S148°24'41.366"E	26.40m	0.35m
11-Oct-1999 02:37:40 38°01'51.240"S148°24'41.372"E	26.30m	0.44m
11-Oct-1999 02:37:50 38°01'51.243"S148°24'41.378"E	26.50m	0.40m
11-Oct-1999 02:38:00 38°01'51.243"S148°24'41.372"E	26.80m	0.35m
11-Oct-1999 02:38:10 38°01'51.235"S148°24'41.378"E	26.80m	0.62m
11-Oct-1999 02:38:20 38°01'51.240"S148°24'41.377"E	26.80m	0.47m
11-Oct-1999 02:38:30 38°01'51.240"S148°24'41.371"E	26.50m	0.43m
11-Oct-1999 02:38:40 38°01'51.238"S148°24'41.377"E	27.00m	0.53m
11-Oct-1999 02:38:50 38°01'51.246"S148°24'41.375"E	26.80m	0.28m
11-Oct-1999 02:39:00 38°01'51.243"S148°24'41.371"E	26.90m	0.34m
11-Oct-1999 02:39:10 38°01'51.247"S148°24'41.377"E	27.30m	0.29m
11-Oct-1999 02:39:20 38°01'51.246"S148°24'41.384"E	27.20m	0.44m
11-Oct-1999 02:39:30 38°01'51.246"S148°24'41.377"E	27.30m	0.31m
11-Oct-1999 02:39:40 38°01'51.250"S148°24'41.375"E	27.20m	0.19m
11-Oct-1999 02:39:50 38°01'51.252"S148°24'41.381"E	27.20m	0.29m

Heading Data

<u>Time</u>	<u>Hdg</u>	<u>Resid</u>
11-Oct-1999 01:58:23206.4°T		0.0°
11-Oct-1999 01:58:30206.4°T		0.0°
11-Oct-1999 01:58:40206.6°T		0.2°
11-Oct-1999 01:58:50206.4°T		0.0°
11-Oct-1999 01:59:00206.4°T		0.0°
11-Oct-1999 01:59:10206.6°T		0.2°
11-Oct-1999 01:59:20206.6°T		0.2°
11-Oct-1999 01:59:30206.4°T		0.0°
11-Oct-1999 01:59:40206.4°T		0.0°
11-Oct-1999 01:59:50206.6°T		0.2°
11-Oct-1999 02:00:00206.6°T		0.2°
11-Oct-1999 02:00:10206.4°T		0.0°
11-Oct-1999 02:00:20206.4°T		0.0°
11-Oct-1999 02:00:30206.6°T		0.2°
11-Oct-1999 02:00:40206.6°T		0.2°
11-Oct-1999 02:00:50206.4°T		0.0°
11-Oct-1999 02:01:00206.4°T		0.0°
11-Oct-1999 02:01:10206.6°T		0.2°
11-Oct-1999 02:01:20206.6°T		0.2°
11-Oct-1999 02:01:30206.4°T		0.0°
11-Oct-1999 02:01:40206.4°T		0.0°
11-Oct-1999 02:01:50206.4°T		0.0°
11-Oct-1999 02:02:00206.6°T		0.2°
11-Oct-1999 02:02:10206.4°T		0.0°
11-Oct-1999 02:02:20206.4°T		0.0°
11-Oct-1999 02:02:30206.4°T		0.0°
11-Oct-1999 02:02:40206.6°T		0.2°
11-Oct-1999 02:02:50206.4°T		0.0°
11-Oct-1999 02:03:00206.4°T		0.0°
11-Oct-1999 02:03:10206.4°T		0.0°
11-Oct-1999 02:03:20206.4°T		0.0°
11-Oct-1999 02:03:30206.4°T		0.0°
11-Oct-1999 02:03:40206.4°T		0.0°
11-Oct-1999 02:03:50206.4°T		0.0°
11-Oct-1999 02:04:00206.6°T		0.2°
11-Oct-1999 02:04:10206.4°T		0.0°
11-Oct-1999 02:04:20206.4°T		0.0°
11-Oct-1999 02:04:30206.4°T		0.0°
11-Oct-1999 02:04:40206.6°T		0.2°
11-Oct-1999 02:04:50206.4°T		0.0°

11-Oct-1999 02:05:00206.4°T	0.0°
11-Oct-1999 02:05:10206.4°T	0.0°
11-Oct-1999 02:05:20206.4°T	0.0°
11-Oct-1999 02:05:30206.4°T	0.0°
11-Oct-1999 02:05:40206.4°T	0.0°
11-Oct-1999 02:05:50206.4°T	0.0°
11-Oct-1999 02:06:00206.4°T	0.0°
11-Oct-1999 02:06:10206.4°T	0.0°
11-Oct-1999 02:06:20206.4°T	0.0°
11-Oct-1999 02:06:30206.4°T	0.0°
11-Oct-1999 02:06:40206.4°T	0.0°
11-Oct-1999 02:06:50206.4°T	0.0°
11-Oct-1999 02:07:00206.4°T	0.0°
11-Oct-1999 02:07:10206.4°T	0.0°
11-Oct-1999 02:07:20206.4°T	0.0°
11-Oct-1999 02:07:30206.4°T	0.0°
11-Oct-1999 02:07:40206.4°T	0.0°
11-Oct-1999 02:07:50206.4°T	0.0°
11-Oct-1999 02:08:00206.4°T	0.0°
11-Oct-1999 02:08:10206.4°T	0.0°
11-Oct-1999 02:08:20206.4°T	0.0°
11-Oct-1999 02:08:30206.4°T	0.0°
11-Oct-1999 02:08:40206.4°T	0.0°
11-Oct-1999 02:08:50206.4°T	0.0°
11-Oct-1999 02:09:00206.4°T	0.0°
11-Oct-1999 02:09:10206.4°T	0.0°
11-Oct-1999 02:09:20206.4°T	0.0°
11-Oct-1999 02:09:30206.4°T	0.0°
11-Oct-1999 02:09:40206.4°T	0.0°
11-Oct-1999 02:09:50206.4°T	0.0°
11-Oct-1999 02:10:00206.4°T	0.0°
11-Oct-1999 02:10:10206.4°T	0.0°
11-Oct-1999 02:10:20206.4°T	0.0°
11-Oct-1999 02:10:30206.4°T	0.0°
11-Oct-1999 02:10:40206.4°T	0.0°
11-Oct-1999 02:10:50206.4°T	0.0°
11-Oct-1999 02:11:00206.4°T	0.0°
11-Oct-1999 02:11:10206.4°T	0.0°
11-Oct-1999 02:11:20206.4°T	0.0°
11-Oct-1999 02:11:30206.4°T	0.0°
11-Oct-1999 02:11:40206.4°T	0.0°
11-Oct-1999 02:11:50206.4°T	0.0°
11-Oct-1999 02:12:00206.4°T	0.0°
11-Oct-1999 02:12:10206.4°T	0.0°
11-Oct-1999 02:12:20206.4°T	0.0°
11-Oct-1999 02:12:30206.4°T	0.0°
11-Oct-1999 02:12:40206.4°T	0.0°
11-Oct-1999 02:12:50206.4°T	0.0°
11-Oct-1999 02:13:00206.4°T	0.0°
11-Oct-1999 02:13:10206.4°T	0.0°
11-Oct-1999 02:13:20206.4°T	0.0°
11-Oct-1999 02:13:30206.4°T	0.0°
11-Oct-1999 02:13:40206.4°T	0.0°
11-Oct-1999 02:13:50206.4°T	0.0°
11-Oct-1999 02:14:00206.4°T	0.0°
11-Oct-1999 02:14:10206.4°T	0.0°
11-Oct-1999 02:14:20206.4°T	0.0°
11-Oct-1999 02:14:30206.4°T	0.0°
11-Oct-1999 02:14:40206.4°T	0.0°
11-Oct-1999 02:14:50206.4°T	0.0°
11-Oct-1999 02:15:00206.4°T	0.0°
11-Oct-1999 02:15:10206.4°T	0.0°

11-Oct-1999 02:15:20206.4°T	0.0°
11-Oct-1999 02:15:30206.4°T	0.0°
11-Oct-1999 02:15:40206.4°T	0.0°
11-Oct-1999 02:15:50206.4°T	0.0°
11-Oct-1999 02:16:00206.4°T	0.0°
11-Oct-1999 02:16:10206.4°T	0.0°
11-Oct-1999 02:16:20206.4°T	0.0°
11-Oct-1999 02:16:30206.4°T	0.0°
11-Oct-1999 02:16:40206.4°T	0.0°
11-Oct-1999 02:16:50206.4°T	0.0°
11-Oct-1999 02:17:00206.4°T	0.0°
11-Oct-1999 02:17:10206.4°T	0.0°
11-Oct-1999 02:17:20206.4°T	0.0°
11-Oct-1999 02:17:30206.4°T	0.0°
11-Oct-1999 02:17:40206.4°T	0.0°
11-Oct-1999 02:17:50206.4°T	0.0°
11-Oct-1999 02:18:00206.4°T	0.0°
11-Oct-1999 02:18:10206.4°T	0.0°
11-Oct-1999 02:18:20206.4°T	0.0°
11-Oct-1999 02:18:30206.4°T	0.0°
11-Oct-1999 02:18:40206.4°T	0.0°
11-Oct-1999 02:18:50206.4°T	0.0°
11-Oct-1999 02:19:00206.4°T	0.0°
11-Oct-1999 02:19:10206.4°T	0.0°
11-Oct-1999 02:19:20206.6°T	0.2°
11-Oct-1999 02:19:30206.4°T	0.0°
11-Oct-1999 02:19:40206.4°T	0.0°
11-Oct-1999 02:19:50206.4°T	0.0°
11-Oct-1999 02:20:00206.4°T	0.0°
11-Oct-1999 02:20:10206.4°T	0.0°
11-Oct-1999 02:20:20206.4°T	0.0°
11-Oct-1999 02:20:30206.4°T	0.0°
11-Oct-1999 02:20:40206.4°T	0.0°
11-Oct-1999 02:20:50206.4°T	0.0°
11-Oct-1999 02:21:00206.4°T	0.0°
11-Oct-1999 02:21:10206.4°T	0.0°
11-Oct-1999 02:21:20206.4°T	0.0°
11-Oct-1999 02:21:30206.4°T	0.0°
11-Oct-1999 02:21:40206.4°T	0.0°
11-Oct-1999 02:21:50206.4°T	0.0°
11-Oct-1999 02:22:00206.4°T	0.0°
11-Oct-1999 02:22:10206.4°T	0.0°
11-Oct-1999 02:22:20206.4°T	0.0°
11-Oct-1999 02:22:30206.4°T	0.0°
11-Oct-1999 02:22:40206.4°T	0.0°
11-Oct-1999 02:22:50206.4°T	0.0°
11-Oct-1999 02:23:00206.4°T	0.0°
11-Oct-1999 02:23:10206.4°T	0.0°
11-Oct-1999 02:23:20206.4°T	0.0°
11-Oct-1999 02:23:30206.4°T	0.0°
11-Oct-1999 02:23:40206.4°T	0.0°
11-Oct-1999 02:23:50206.4°T	0.0°
11-Oct-1999 02:24:00206.4°T	0.0°
11-Oct-1999 02:24:10206.4°T	0.0°
11-Oct-1999 02:24:20206.4°T	0.0°
11-Oct-1999 02:24:30206.4°T	0.0°
11-Oct-1999 02:24:40206.4°T	0.0°
11-Oct-1999 02:24:50206.4°T	0.0°
11-Oct-1999 02:25:00206.4°T	0.0°
11-Oct-1999 02:25:10206.4°T	0.0°
11-Oct-1999 02:25:20206.4°T	0.0°
11-Oct-1999 02:25:30206.4°T	0.0°

11-Oct-1999 02:25:40206.4°T	0.0°
11-Oct-1999 02:25:50206.4°T	0.0°
11-Oct-1999 02:26:00206.4°T	0.0°
11-Oct-1999 02:26:10206.4°T	0.0°
11-Oct-1999 02:26:20206.4°T	0.0°
11-Oct-1999 02:26:30206.4°T	0.0°
11-Oct-1999 02:26:40206.4°T	0.0°
11-Oct-1999 02:26:50206.4°T	0.0°
11-Oct-1999 02:27:00206.4°T	0.0°
11-Oct-1999 02:27:10206.4°T	0.0°
11-Oct-1999 02:27:20206.4°T	0.0°
11-Oct-1999 02:27:30206.4°T	0.0°
11-Oct-1999 02:27:40206.4°T	0.0°
11-Oct-1999 02:27:50206.4°T	0.0°
11-Oct-1999 02:28:00206.4°T	0.0°
11-Oct-1999 02:28:10206.4°T	0.0°
11-Oct-1999 02:28:20206.4°T	0.0°
11-Oct-1999 02:28:30206.4°T	0.0°
11-Oct-1999 02:28:40206.4°T	0.0°
11-Oct-1999 02:28:50206.4°T	0.0°
11-Oct-1999 02:29:00206.4°T	0.0°
11-Oct-1999 02:29:10206.4°T	0.0°
11-Oct-1999 02:29:20206.4°T	0.0°
11-Oct-1999 02:29:30206.4°T	0.0°
11-Oct-1999 02:29:40206.4°T	0.0°
11-Oct-1999 02:29:50206.4°T	0.0°
11-Oct-1999 02:30:00206.4°T	0.0°
11-Oct-1999 02:30:10206.4°T	0.0°
11-Oct-1999 02:30:20206.4°T	0.0°
11-Oct-1999 02:30:30206.4°T	0.0°
11-Oct-1999 02:30:40206.4°T	0.0°
11-Oct-1999 02:30:50206.4°T	0.0°
11-Oct-1999 02:31:00206.4°T	0.0°
11-Oct-1999 02:31:10206.4°T	0.0°
11-Oct-1999 02:31:20206.4°T	0.0°
11-Oct-1999 02:31:30206.4°T	0.0°
11-Oct-1999 02:31:40206.4°T	0.0°
11-Oct-1999 02:31:50206.4°T	0.0°
11-Oct-1999 02:32:00206.4°T	0.0°
11-Oct-1999 02:32:10206.4°T	0.0°
11-Oct-1999 02:32:20206.4°T	0.0°
11-Oct-1999 02:32:30206.4°T	0.0°
11-Oct-1999 02:32:40206.4°T	0.0°
11-Oct-1999 02:32:50206.4°T	0.0°
11-Oct-1999 02:33:00206.4°T	0.0°
11-Oct-1999 02:33:10206.4°T	0.0°
11-Oct-1999 02:33:20206.4°T	0.0°
11-Oct-1999 02:33:30206.4°T	0.0°
11-Oct-1999 02:33:40206.4°T	0.0°
11-Oct-1999 02:33:50206.4°T	0.0°
11-Oct-1999 02:34:00206.4°T	0.0°
11-Oct-1999 02:34:10206.4°T	0.0°
11-Oct-1999 02:34:20206.4°T	0.0°
11-Oct-1999 02:34:30206.4°T	0.0°
11-Oct-1999 02:34:40206.4°T	0.0°
11-Oct-1999 02:34:50206.4°T	0.0°
11-Oct-1999 02:35:00206.4°T	0.0°
11-Oct-1999 02:35:10206.4°T	0.0°
11-Oct-1999 02:35:20206.4°T	0.0°
11-Oct-1999 02:35:30206.4°T	0.0°
11-Oct-1999 02:35:40206.4°T	0.0°
11-Oct-1999 02:35:50206.4°T	0.0°

APPENDIX C

SYSTEM DATA PRINTOUTS

FINAL SYSTEMS REPORT
BALEEN2 SURVEY
CULTUS PETROLEUM
2930A3

11/10/99

903058 295

GNS II CONFIGURATION FILE C:\CultusBaleen2\CultusBaleen2.gns

JOB DETAILS

Job Number : 2930A3
Job Description : Survey
Company : Racal Survey Group Ltd
Client : Cultus Petroleum

WORKING SPHEROID

AGD66
Semi-major : 6378160.000 m
e Squared : 0.006694541855

WORKING PROJECTION

AMG Zone 55
Lat of Origin : 00°00'00.000"N
Long of Origin : 147°00'00.000"E
False Easting : 500000.00
False Northing : 10000000.00
Scale Factor : 0.999600
Units : Metres

GPS TRANSFORMATION

From : WGS 84
Semi-major : 6378137.000 m
e Squared : 0.006694380067
To : AGD66
Dx : 123.314 m
Dy : 47.223 m
Dz : -136.594 m
Rot x : 0.2640 secs
Rot y : 0.3220 secs
Rot z : 0.2700 secs
Scale : 1.3840 ppm

WAYPOINTS

Waypoint	E	N	Ht	Tol1	Tol2
Baleen-2 Well	623782.00	5789663.00	0.00 m	20.00 m	
Barramundi	391413.90	5609012.80	0.00 m	0.00 m	10.00 m
Blackback	635083.02	5732929.69	0.00 m	0.00 m	5.00 m
Wp1	471391.60	5613794.43	0.00 m		
WP2	613571.97	5701815.09	0.00 m		
WP3	645808.83	5723490.75	0.00 m		
WP4	642076.21	5758710.00	0.00 m		
WP5	635874.46	5780091.16	0.00 m		
WP6	627324.32	5794103.13	0.00 m		
WP7	628494.27	5793211.56	0.00 m		

TRACK GUIDANCE

anch 6
SOL E: 623889.90 N: 5790557.30 EOL E: 623773.00 N: 5789712.50 KJ

Verified by: (sign) _____ (print) _____

01:56 11-Oct-99

Page 1 of 3

GNS II CONFIGURATION FILE C:\CultusBaleen2\CultusBaleen2.gns

Anch 7

SOL E: 624364.31 N: 5790083.37 EOL E: 623829.80 N: 5789678.68 KJ
 run in 7
 SOL E: 635874.50 N: 5780091.10 KP: 0.000 EOL E: 630886.00 N: 5792587.00 KJ
 SOC E: 630886.00 N: 5792587.00 KP: 13.457 EOC E: 628481.00 N: 5793216.00 KJ
 CC E: 629386.41 N: 5791765.56 Radius: 1709.83 m
 SOL E: 628481.00 N: 5793216.00 KP: 16.241 EOL E: 623829.00 N: 5789679.00 KJ

MOBILES

Sedco 702 (semi-sub rig)

Shape: Sedco702

SOL:-

X: 0.00 m Y: 35.00 m
 X: -22.90 m Y: 35.00 m
 X: -30.50 m Y: 45.70 m
 X: -38.10 m Y: 35.00 m
 X: -38.10 m Y: -45.70 m
 X: -22.90 m Y: -45.70 m
 X: -22.90 m Y: -35.00 m
 X: 22.90 m Y: -35.00 m
 X: 22.90 m Y: -45.70 m
 X: 38.10 m Y: -45.70 m
 X: 38.10 m Y: 35.00 m
 X: 30.50 m Y: 45.70 m
 X: 22.90 m Y: 35.00 m
 X: 0.00 m Y: 35.00 m

Offsets:-

Datum	X: 0.00 m	Y: 0.00 m	Z: 0.00 m	Rng: 0.00 m	Brg:
gps1	X: 1.90 m	Y: 35.80 m	Z: 0.00 m	Rng: 35.85 m	Brg:
Winch 7	X: -33.00 m	Y: -38.00 m	Z: 0.00 m	Rng: 50.33 m	Brg: 50.33 m
Winch 6	X: 33.00 m	Y: -38.00 m	Z: 0.00 m	Rng: 50.33 m	Brg: 50.33 m

Tracking Point : Datum

Pitch and Roll Centre: Datum

Selected Sources:-

Primary Position : R1 Racal UKOOA
 Primary Heading : S1 SGB 1000S
 Primary Height : Datum Displacement
 Pitch and Roll : Manual
 Soundings : Manual
 Speed : Position Filter
 Course Made Good : Posn Filter CMG

Equipment:-

R1 Racal UKOOA

Verified by: (sign) _____ (print) _____

01:56 11-Oct-99

Page 2 of 3

GNS II CONFIGURATION FILE C:\CultusBaleen2\CultusBaleen2.gns

Status: ON Interface: COM3
 Ant: gps1 X: 1.90 m Y: 35.80 m Z: 0.00 m Rng: 35.85 m
 Apply Pitch and Roll: Off Stale Time: 5.0 s Posn SD: 3.0 m Ht SD: 1.0 m

S1 SGB 1000S

Status: ON Interface: COM7
 C-O: -0.4 degs Stale Time: 5.0 s SD: 0.1 degs

ANCHORS

Sedco 702

Fairleads:-

Fairlead 1	X: -35.00 m	Y: 35.00 m	Z: 0.00 m	Rng: 49.50 m	Brg: 30
Fairlead 2	X: -33.00 m	Y: 38.00 m	Z: 0.00 m	Rng: 50.33 m	Brg: 30
Fairlead 3	X: 33.00 m	Y: 38.00 m	Z: 0.00 m	Rng: 50.33 m	Brg: 30
Fairlead 4	X: 35.00 m	Y: 35.00 m	Z: 0.00 m	Rng: 49.50 m	Brg: 30
Fairlead 5	X: 35.00 m	Y: -35.00 m	Z: 0.00 m	Rng: 49.50 m	Brg: 15
Fairlead 6	X: 33.00 m	Y: -38.00 m	Z: 0.00 m	Rng: 50.33 m	Brg: 15
Fairlead 7	X: -33.00 m	Y: -38.00 m	Z: 0.00 m	Rng: 50.33 m	Brg: 20
Fairlead 8	X: -35.00 m	Y: -35.00 m	Z: 0.00 m	Rng: 49.50 m	Brg: 20

Main Intended Positions:-

Anchor 1	E: 624244.75	N: 5789026.58	Dep: 0.00 m	Tol: 0.00 m
Anchor 2	E: 623694.46	N: 5788893.21	Dep: 0.00 m	Tol: 0.00 m
Anchor 3	E: 623149.25	N: 5789201.08	Dep: 0.00 m	Tol: 0.00 m
Anchor 4	E: 623038.21	N: 5789744.44	Dep: 0.00 m	Tol: 0.00 m
Anchor 5	E: 623333.06	N: 5790283.60	Dep: 0.00 m	Tol: 0.00 m
Anchor 6	E: 623868.84	N: 5790424.30	Dep: 0.00 m	Tol: 0.00 m
Anchor 7	E: 624361.79	N: 5790085.05	Dep: 0.00 m	Tol: 0.00 m
Anchor 8	E: 624556.81	N: 5789577.73	Dep: 0.00 m	Tol: 0.00 m

Main Actual Positions:-

Anchor 1	E: 624244.75	N: 5789026.58	Dep: 0.00 m	Tol: 0.00 m
Anchor 2	E: 623694.46	N: 5788893.20	Dep: 0.00 m	Tol: 0.00 m
Anchor 3	E: 623149.25	N: 5789201.07	Dep: 0.00 m	Tol: 0.00 m
Anchor 4	E: 623038.20	N: 5789744.40	Dep: 0.00 m	Tol: 0.00 m
Anchor 5	E: 623333.10	N: 5790283.60	Dep: 0.00 m	Tol: 0.00 m
Anchor 6	E: 623868.84	N: 5790424.30	Dep: 0.00 m	Tol: 0.00 m
Anchor 7	E: 624361.80	N: 5790085.05	Dep: 0.00 m	Tol: 0.00 m
Anchor 8	E: 624556.80	N: 5789577.70	Dep: 0.00 m	Tol: 0.00 m

Verified by: (sign) N. O'Leary (print) _____

01:56 11-Oct-99

Page 3 of 3

908058 298

APPENDIX D

DIFFERENTIAL GPS CHECK FIX AT BARRAMUNDI-1

RACAL Racal Survey Group Ltd
FINAL POSITION FIX – DIFFERENTIAL GPS

Job: Survey
 Job Number: 2930A3
 Racal Surveyor: Troy Langley
 Client: Cultus Petroleum
 Client Representative: R.Kahut

Sampling started: 5 Oct 1999 21:44:51
 Sampling end: 5 Oct 1999 21:52:59

Sedco 702

Intended datum location

Datum: AGD66
 Latitude: 39°39'41.988"S Longitude: 145°44'02.937"E
 Projection: AMG Zone 55
 Easting: 391413.90 Northing: 5609012.80

Final Antenna Position (R1 Racal UKOOA):

Sample size: 49 fixes used out of a total of 50.

Antenna offset

X: 1.90m Y: 35.80m Z: 0.00m
 Range: 35.85m Rel Brg from datum to antenna: 3.0°

Datum: WGS 84
 Latitude: 39°39'37.501"S Longitude: 145°44'06.877"E Spheroidal Ht: 19.98m
 Datum: AGD66
 Latitude: 39°39'42.903"S Longitude: 145°44'02.088"E Spheroidal Ht: 35.27m
 Projection: AMG Zone 55
 Easting: 391394.08 Northing: 5608984.33 Spheroidal Ht: 35.27m

Standard deviations

Long or E: 0.41m
 Lat or N: 0.41m
 Height: 0.62m
 Position: 0.58m

Final Datum Position

Datum: AGD66
 Latitude: 39°39'41.930"S Longitude: 145°44'02.912"E Spheroidal Ht: 35.27m
 Projection: AMG Zone 55
 Easting: 391413.29 Northing: 5609014.59 Spheroidal Ht: 35.27m

Mean corrected heading: 209.4°T
 SD heading: 0.1°T
 Intended heading: 210.0°T
 Difference from intended: -0.6°

Final Datum Position is 1.89m on a bearing of 342.1°T (341.3°G) from the intended location.

Raw Data

Sedco 702

Position Data

Antenna (R1 Racal UKOOA):

Datum: WGS 84

<u>Time</u>	<u>Latitude</u>	<u>Longitude</u>	<u>Spheroidal Ht</u>	<u>Resid</u>
5-Oct-1999 21:44:51	39°39'37.484"S	145°44'06.852"E	19.20m	0.80m
5-Oct-1999 21:45:00	39°39'37.485"S	145°44'06.842"E	18.70m	0.98m
5-Oct-1999 21:45:10	39°39'37.479"S	145°44'06.860"E	18.60m	0.80m
5-Oct-1999 21:45:30	39°39'37.478"S	145°44'06.849"E	18.80m	0.98m
5-Oct-1999 21:45:40	39°39'37.478"S	145°44'06.858"E	19.00m	0.85m
5-Oct-1999 21:45:50	39°39'37.476"S	145°44'06.865"E	18.80m	0.83m
5-Oct-1999 21:46:00	39°39'37.487"S	145°44'06.873"E	19.20m	0.45m
5-Oct-1999 21:46:10	39°39'37.484"S	145°44'06.884"E	19.10m	0.55m
5-Oct-1999 21:46:20	39°39'37.484"S	145°44'06.875"E	19.20m	0.53m
5-Oct-1999 21:46:30	39°39'37.484"S	145°44'06.870"E	19.10m	0.56m
5-Oct-1999 21:46:40	39°39'37.482"S	145°44'06.873"E	19.30m	0.60m
5-Oct-1999 21:46:50	39°39'37.482"S	145°44'06.868"E	19.90m	0.63m
5-Oct-1999 21:47:00	39°39'37.493"S	145°44'06.857"E	20.00m	0.55m
5-Oct-1999 21:47:10	39°39'37.485"S	145°44'06.858"E	19.50m	0.68m
5-Oct-1999 21:47:20	39°39'37.493"S	145°44'06.862"E	19.70m	0.45m
5-Oct-1999 21:47:30	39°39'37.496"S	145°44'06.865"E	19.90m	0.34m
5-Oct-1999 21:47:40	39°39'37.497"S	145°44'06.873"E	19.90m	0.17m
5-Oct-1999 21:47:50	39°39'37.509"S	145°44'06.873"E	20.00m	0.27m
5-Oct-1999 21:48:00	39°39'37.508"S	145°44'06.886"E	20.20m	0.29m
5-Oct-1999 21:48:10	39°39'37.508"S	145°44'06.892"E	20.30m	0.41m
5-Oct-1999 21:48:20	39°39'37.512"S	145°44'06.894"E	20.20m	0.52m
5-Oct-1999 21:48:30	39°39'37.520"S	145°44'06.910"E	20.40m	0.97m
5-Oct-1999 21:48:40	39°39'37.520"S	145°44'06.908"E	20.60m	0.93m
5-Oct-1999 21:48:50	39°39'37.518"S	145°44'06.900"E	20.60m	0.75m
5-Oct-1999 21:49:00	39°39'37.508"S	145°44'06.903"E	20.50m	0.64m
5-Oct-1999 21:49:10	39°39'37.508"S	145°44'06.897"E	20.70m	0.51m
5-Oct-1999 21:49:20	39°39'37.515"S	145°44'06.875"E	21.00m	0.43m
5-Oct-1999 21:49:30	39°39'37.505"S	145°44'06.871"E	20.60m	0.20m
5-Oct-1999 21:49:40	39°39'37.506"S	145°44'06.855"E	20.50m	0.56m
5-Oct-1999 21:49:50	39°39'37.502"S	145°44'06.857"E	20.80m	0.49m
5-Oct-1999 21:50:00	39°39'37.499"S	145°44'06.863"E	20.70m	0.35m
5-Oct-1999 21:50:10	39°39'37.506"S	145°44'06.873"E	20.90m	0.18m
5-Oct-1999 21:50:20	39°39'37.508"S	145°44'06.879"E	20.30m	0.22m
5-Oct-1999 21:50:30	39°39'37.512"S	145°44'06.894"E	20.30m	0.52m
5-Oct-1999 21:50:40	39°39'37.517"S	145°44'06.892"E	20.50m	0.60m
5-Oct-1999 21:50:50	39°39'37.515"S	145°44'06.884"E	20.10m	0.46m
5-Oct-1999 21:51:00	39°39'37.509"S	145°44'06.894"E	19.90m	0.46m
5-Oct-1999 21:51:10	39°39'37.512"S	145°44'06.894"E	19.90m	0.52m
5-Oct-1999 21:51:20	39°39'37.509"S	145°44'06.900"E	20.00m	0.59m
5-Oct-1999 21:51:30	39°39'37.512"S	145°44'06.900"E	20.40m	0.63m
5-Oct-1999 21:51:40	39°39'37.512"S	145°44'06.883"E	20.00m	0.36m
5-Oct-1999 21:51:50	39°39'37.500"S	145°44'06.892"E	19.90m	0.35m
5-Oct-1999 21:52:00	39°39'37.502"S	145°44'06.865"E	20.00m	0.30m
5-Oct-1999 21:52:10	39°39'37.500"S	145°44'06.862"E	20.10m	0.37m
5-Oct-1999 21:52:20	39°39'37.506"S	145°44'06.866"E	20.00m	0.31m
5-Oct-1999 21:52:30	39°39'37.511"S	145°44'06.870"E	20.30m	0.35m
5-Oct-1999 21:52:40	39°39'37.506"S	145°44'06.886"E	20.30m	0.25m

5-Oct-1999 21:52:50 39°39'37.512"S 145°44'06.897"E
 5-Oct-1999 21:53:00 39°39'37.520"S 145°44'06.897"E

20.40m
 20.50m

0.57m
 0.75m

Heading Data

<u>Time</u>	<u>Hdg</u>	<u>Resid</u>
5-Oct-1999 21:44:51	209.3°T	0.0°
5-Oct-1999 21:45:00	209.3°T	0.0°
5-Oct-1999 21:45:10	209.5°T	0.1°
5-Oct-1999 21:45:20	209.5°T	0.1°
5-Oct-1999 21:45:30	209.5°T	0.1°
5-Oct-1999 21:45:40	209.7°T	0.3°
5-Oct-1999 21:45:50	209.5°T	0.1°
5-Oct-1999 21:46:00	209.5°T	0.1°
5-Oct-1999 21:46:10	209.3°T	0.0°
5-Oct-1999 21:46:20	209.3°T	0.0°
5-Oct-1999 21:46:30	209.5°T	0.1°
5-Oct-1999 21:46:40	209.5°T	0.1°
5-Oct-1999 21:46:50	209.7°T	0.3°
5-Oct-1999 21:47:00	209.5°T	0.1°
5-Oct-1999 21:47:10	209.5°T	0.1°
5-Oct-1999 21:47:20	209.3°T	0.0°
5-Oct-1999 21:47:30	209.3°T	0.0°
5-Oct-1999 21:47:40	209.3°T	0.0°
5-Oct-1999 21:47:50	209.3°T	0.0°
5-Oct-1999 21:48:00	209.5°T	0.1°
5-Oct-1999 21:48:10	209.5°T	0.1°
5-Oct-1999 21:48:20	209.5°T	0.1°
5-Oct-1999 21:48:30	209.5°T	0.1°
5-Oct-1999 21:48:40	209.3°T	0.0°
5-Oct-1999 21:48:50	209.3°T	0.0°
5-Oct-1999 21:49:00	209.2°T	0.2°
5-Oct-1999 21:49:10	209.2°T	0.2°
5-Oct-1999 21:49:20	209.3°T	0.0°
5-Oct-1999 21:49:30	209.3°T	0.0°
5-Oct-1999 21:49:40	209.5°T	0.1°
5-Oct-1999 21:49:50	209.5°T	0.1°
5-Oct-1999 21:50:00	209.5°T	0.1°
5-Oct-1999 21:50:10	209.3°T	0.0°
5-Oct-1999 21:50:20	209.2°T	0.2°
5-Oct-1999 21:50:30	209.2°T	0.2°
5-Oct-1999 21:50:40	209.3°T	0.0°
5-Oct-1999 21:50:50	209.5°T	0.1°
5-Oct-1999 21:51:00	209.5°T	0.1°
5-Oct-1999 21:51:10	209.5°T	0.1°
5-Oct-1999 21:51:20	209.2°T	0.2°
5-Oct-1999 21:51:30	209.2°T	0.2°
5-Oct-1999 21:51:40	209.2°T	0.2°
5-Oct-1999 21:51:50	209.2°T	0.2°
5-Oct-1999 21:52:00	209.3°T	0.0°
5-Oct-1999 21:52:10	209.5°T	0.1°
5-Oct-1999 21:52:20	209.5°T	0.1°
5-Oct-1999 21:52:30	209.3°T	0.0°
5-Oct-1999 21:52:40	209.2°T	0.2°
5-Oct-1999 21:52:50	209.0°T	0.4°
5-Oct-1999 21:53:00	209.2°T	0.2°

908058 302

APPENDIX E

GYRO CALIBRATION

#2930 AB SIKKOTK

CULTS RETURN

SPADE (v4.2) Copyright (c) 1991 Michael R. Craymer
2930A3-2nd

Date : 6 Oct 1999
 Method : Solar Hour Angle
 Latitude (D.MMSSs) : -39.3937
 Longitude West (D.MMSSs) : -145.4407
 Watch Corr: UT-Watch (H.MMSSs) : 0.00000
 Error in Latitude (arcsec) : 5.0
 Error in Timing (sec of time) : 0.5
 Output Filename : BALEEN2

Set No.	Average Watch Time (HH.MMSSs)	Average Horz.Ang (DD.MMSSs)	Azimuth Star (DD.MMSSs)	Azimuth RO (HH.MMSSs)
1	7.5900	56.5200	267.0950	210.1750
0.0005				
2	8.0000	56.4200	267.0018	210.1818
0.0005				
3	8.0030	56.3600	266.5532	210.1932
0.0005				
4	8.0130	56.5000	266.4559	209.5559
0.0005				
5	8.0200	56.1700	266.4113	210.2413
0.0005				
6	8.0230	56.2800	266.3626	210.0826
0.0005				
7	8.0300	56.0600	266.3140	210.2540
0.0005				
8	8.0330	56.1200	266.2654	210.1454
0.0005				
9	8.0400	56.0700	266.2207	210.1507
0.0005				
10	8.0430	56.0400	266.1721	210.1321
0.0005				

Average Azimuth

Set No.	Azimuth RO (DD.MMSSs)	Error (DD.MMSSs)
1	210.1750	0.0005
2	210.1818	0.0005
3	210.1932	0.0005
4	209.5559	0.0005
5	210.2413	0.0005
6	210.0826	0.0005
7	210.2540	0.0005

8	210.1454	0.0005
9	210.1507	0.0005
10	210.1321	0.0005

Average Azimuth RO : 210.1520

2nd SET OF GYRO CAGES

CULTUS PETROLEUM-

17:57:04 Logging started
C:\CultusBaleen2\LOG\#.294

#2930 A3 S-XG 702

908058 305

138 @ 6-Oct-1999 17:57:04 Logging: ON

Sedco 702 Offset Datum X: 0.00m Y: 0.00m
 E: 391415.56 N: 5609014.66 Ht(S): 36.69m Lat: 39°39'41.929"S Lng: 145°44'03.007"E
 E: 391396.18 N: 5608984.51
 Winch 7 E: 391463.04 N: 5609031.33
 Winch 6 E: 391405.72 N: 5609064.01

Hdg: 210.5°T Corr: 0.0° Spd: 0.0kts Pitch: ???° Roll: ???° Heave: ???m Sounding: ???m

Barramundi Rng: 2.50m Brg: 221.7°G

TG Line: Sedco -:Seg 1 DOffL: -2.36m DToGo:366423.91m

R1 Rascal UK00A (Tracking) Datum E: 391415.56 N: 5609014.66 Ht(S): 36.69m

Antenna Lat: 39°39'37.496"S Lng: 145°44'06.966"E Ht: 21.40m

Mobile	Easting	Northing	Heading	Speed	Wpt Rng	Wpt Brg	DOffL	DToGo
Fix: 139 @ 6-Oct-1999 17:58:04								
Sedco 702	391415.33	5609014.11	209.7°G	0.0kts	1.94m	227.6°G	-1.81m	366424.31m
Fix: 140 @ 6-Oct-1999 17:59:04								
Sedco 702	391414.85	5609014.01	209.9°G	0.0kts	1.54m	218.1°G	-1.75m	366424.81m
Fix: 141 @ 6-Oct-1999 18:00:04								
Sedco 702	391415.61	5609013.87	209.9°G	0.0kts	2.02m	238.1°G	-1.56m	366424.11m
Fix: 142 @ 6-Oct-1999 18:01:04								
Sedco 702	391414.80	5609013.40	210.0°G	0.0kts	1.08m	236.5°G	-1.14m	366425.05m
Fix: 143 @ 6-Oct-1999 18:02:04								
Sedco 702	391415.09	5609013.46	209.9°G	0.0kts	1.36m	241.1°G	-1.18m	366424.74m
Fix: 144 @ 6-Oct-1999 18:03:04								
Sedco 702	391414.44	5609013.45	210.0°G	0.0kts	0.85m	219.7°G	-1.21m	366425.39m
Fix: 145 @ 6-Oct-1999 18:04:04								
Sedco 702	391414.96	5609013.52	209.7°G	0.0kts	1.28m	236.0°G	-1.24m	366424.86m
Fix: 146 @ 6-Oct-1999 18:05:04								
Sedco 702	391415.35	5609013.86	209.9°G	0.0kts	1.80m	233.8°G	-1.57m	366424.37m
Fix: 147 @ 6-Oct-1999 18:06:04								
Sedco 702	391415.05	5609013.58	209.9°G	0.0kts	1.39m	235.7°G	-1.31m	366424.75m

18:07:01 Logging stopped

2nd Gyro Calibration #2930A3 Cultus Petroleum Sedco 702 6 Oct 1999

Gyro

Time	Observations	Computed Azimuth	Observed Grid	Convergence	TRUE	C-O
17:59:00	1	210.30	209.9	0.81	210.71	-0.4
18:00:00	2	210.31	209.9	0.81	210.71	-0.4
18:00:30	3	210.33	209.9	0.81	210.71	-0.4
18:01:30	4	209.93	209.9	0.81	210.5	-0.6
18:02:00	5	210.40	209.9	0.81	210.71	-0.3
18:02:30	6	210.14	209.9	0.81	210.71	-0.6
18:03:00	7	210.43	210.0	0.81	210.81	-0.4
18:03:30	8	210.25	209.8	0.81	210.61	-0.4
18:04:00	9	210.25	209.7	0.81	210.51	-0.3
18:04:30	10	210.22	209.8	0.81	210.61	-0.4
Average=						-0.4

APPENDIX E

GRAPHIC DUMPS ON FINAL LOCATION

903058 308

Survey
02:55:07 11 Oct 1999

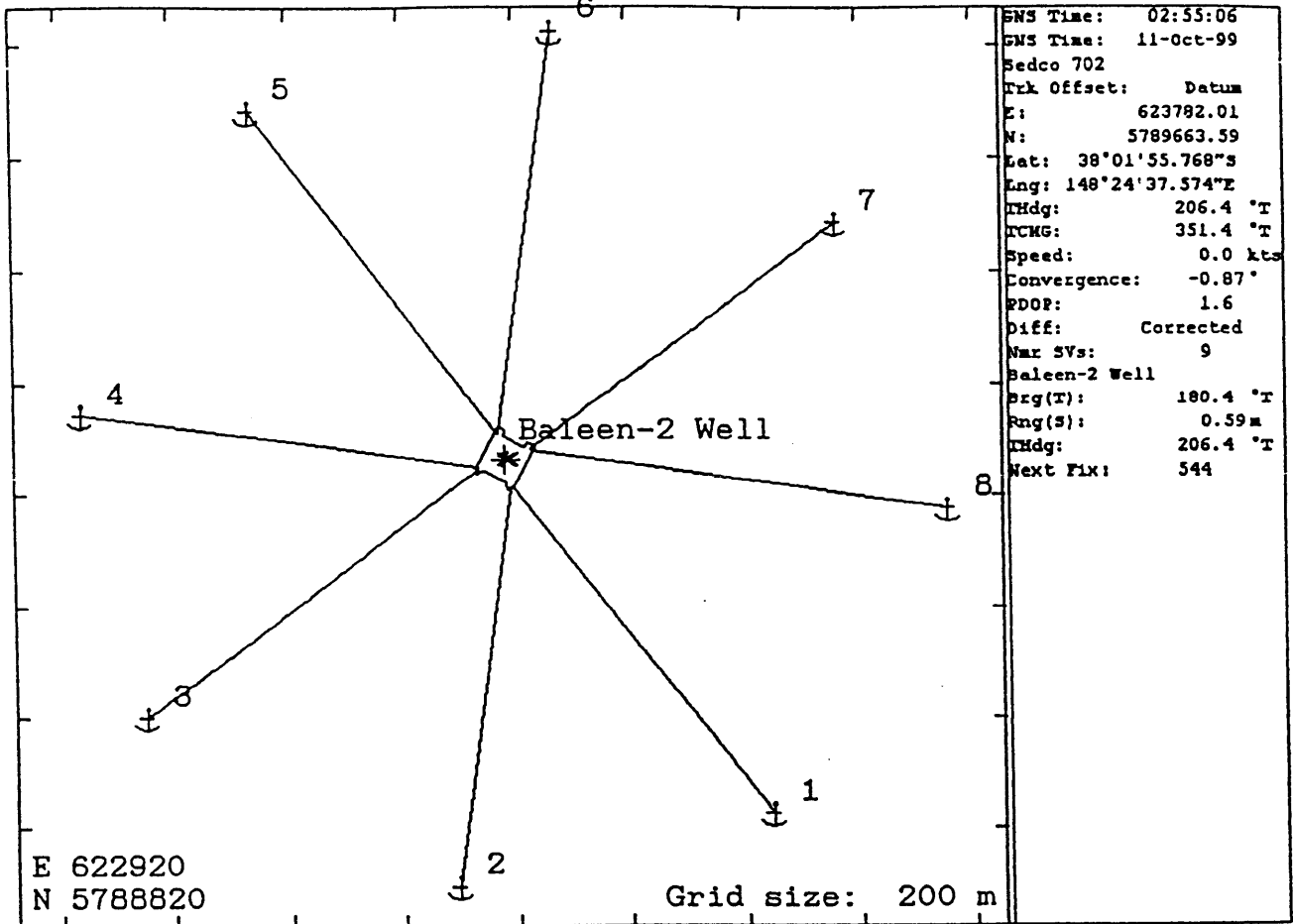

02:55:11 11 Oct 1999

Sedco 702	
Fairleads Actual 1	
Brg(T):	141.9 °T
Rng(S):	2429.91ft
Fairleads Actual 2	
Brg(T):	187.0 °T
Rng(S):	2390.27ft
Fairleads Actual 3	
Brg(T):	232.0 °T
Rng(S):	2412.96ft
Fairleads Actual 4	
Brg(T):	277.0 °T
Rng(S):	2308.13ft
Fairleads Actual 5	
Brg(T):	322.0 °T
Rng(S):	2358.31ft
Fairleads Actual 6	
Brg(T):	7.0 °T
Rng(S):	2357.94ft
Fairleads Actual 7	
Brg(T):	52.0 °T
Rng(S):	2192.01ft
Fairleads Actual 8	
Brg(T):	97.0 °T
Rng(S):	2410.20ft

APPENDIX G

DAILY LOG SHEETS

Date: 5/10/04 Client: CULTUS Job No.: 2730 AB Vessel: SEVCO 702 Location: BALEEN 2

Equipment	Op	
SkyFix		✓
LandStar		✓
Gyro		✓
PCGNS		✓
MultiFix II		✓
GRREP		✓
SkyTrac		

Equipment	Op	
Deso Echo Sounder		
Sidescan		
Boomer		
Heave Co.		
STD-12		
ENSIN		

Racal Personnel
T. LAUNLEY
C. WANKLETTES
Client Personnel
R. KAHOT

WX	Sea State	Swell	Wind Dir.
0000			
0600			
1200			
1800			

DIARY OF OPERATIONS

TIME	Time Zone = UTC+10 E.S.T.
08:00	T.L + K.H. MEASURED OFFSETS FOR GPS ANTENNAE
08:30	#5 P.C.R. PASSED TO PACIFIC CHALLENGER
08:34	#1 P.C.R. PASSED TO PACIFIC SNOGOW.
08:55	PACIFIC CHALLENGER AT ANCHOR
09:00	PACIFIC SNOGOW AT ANCHOR
09:00	WAITING FOR CONFIRMATION THAT CASING IS LATCHED OUT, WAS TO PULL
09:46	PERMISSION TO PULL SECONDARY ANCHORS
10:50	#1 D. RACLED
11:04	#5 D. RACLED
11:18	#8 P.C.R. PASSED TO PACIFIC SNOGOW
11:40	PACIFIC SNOGOW AT ANCHOR #8
11:42	#4 P.C.R. PASSED TO PACIFIC CHALLENGER
11:55	#8 COMMENCED HEAVING IN.
12:15	PACIFIC CHALLENGER AT ANCHOR 4
12:28	#4 AT ROLLER + COMMENCED HEAVING IN #4
12:50	SHUT DOWN IN ANCHOR OPERATIONS AS THE RIG WAS PULLED OFF LOCATION (PROBLEMS WITH THE CATCH OF THE CASING RIG STILL ATTACHED TO THE HULL)
14:45	#4 RECOMMENCED HEAVING IN.
15:15	#8 RECOMMENCED HEAVING IN.
15:22	#8 RACLED
15:35	#4 RACLED
15:40	STANBY BY FOR PERMISSION TO PULL PRIMARY ANCHORS
19:05	HELICOPTER ON DECK WITH NAVIGATION GEAR
19:47	HELICOPTER DEPARTED
20:00	STARTED MESSING GEAR
23:00	ALL CABLES, ANTENNAE + EQUIPMENT INSTALLED + OPERATIONAL

Forms are to be completed daily in duplicate on all vessels. Each form should be countersigned by the Clients Representative, the original being retained on board until the next crew change or at the end of job, whichever is the earlier, when they should be returned to the PERTH office.

Signature

477
SURVEYOR/ENGINEER

WHITE : Accounts Department
BLUE : Operations Department
YELLOW : Clients Representative

Signature

W. Edmund
CLIENT REPRESENTATIVE

Date: 8/10/99 Client: CULTUS Job No.: 2930 A3 Vessel: SERPENT Location: BALLIN

Equipment	Op
SkyFix	/
LandStar	/
Gyro	/
PCGNS	/
MultiFix II	/
GRREP	/
SkyTrac	/

Equipment	Op
Deso Echo Sounder	
Sidescan	
Boomer	
Heave Co.	
STD-12	
ENSIN	

Racal Personnel
T. LANGLEY
C. HAYKIN
Client Personnel
R. WALKER
S. LEWIS

WX	Sea State	Swell	Wind Dir.
0000			
0600			
1200			
1800			

DIARY OF OPERATIONS

TIME	Time Zone = UTC+
00:01	39° 35' S 146° 50' E
04:00	39° 26' S 147° 02' E
08:00	39° 32' S 147° 12' E
11:30	SURVEY CLIENT REP LANDED ON DECK WILL LEWIS
12:00	39° 38' S 147° 21' E
14:00	PROCESSED SYSTEMS DUMP + GYRO CALC + HANDED TO CLIENT REP
16:00	39° 10' S 147° 42' E
20:00	39° 05' S 147° 42' E
21:45	POWER FAILURE ALL NAV GEAR DOWN.
22:10	SYSTEM BACK UP + RUNNING
23:00	POWER FAILURE ALL NAV GEAR DOWN.
23:16	SYSTEM BACK UP + RUNNING

Forms are to be completed daily in duplicate on all vessels. Each form should be countersigned by the Clients Representative, the original being retained on board until the next crew change or at the end of job, whichever is the earlier, when they should be returned to the PERTH office.

Signature: *[Handwritten Signature]*
Well Completion Engineer

WHITE	: Accounts Department
BLUE	: Operations Department
YELLOW	: Clients Representative

Signature: *[Handwritten Signature]*
Clients Representative



RACAL SURVEY AUSTRALIA LIMITED

DAILY RECORD SHEET 908058 317

Date: 10/09/99 Client: CUBUS Job No.: 2950 A3 Vessel: SLEWOTOL Location: BALISEL 2

PAGE 8 OF 10

Equipment	Op	
SkyFix		/
LandStar		/
Gyro		/
PCGNS		/
MultiFix II		/
GRREP		/
SkyTrac		

Equipment	Op	
Deso Echo Sounder		
Sidescan		
Boomer		
Heave Co.		
STD-12		
ENSIN		

Racal Personnel
T. LAGLEY
C. HAYNES
Client Personnel
P. HART
D. EDWARDS

WX	Sea State	Swell	Wind Dir.
0000			
0600			
1200			
1800			

DIARY OF OPERATIONS

TIME	Time Zone = UTC+
08:00	38°25'S 148°31'SE
08:00	38°14'S 148°36'E
08:00	38°08'S 148°34'39"E
09:00	ALL SYSTEMS PARAMETERS RECHECKED (BY TL + BL)
10:00	EMERGENCY MUSTER DRILL
10:15	STARTED RUN IN TO ANCHOR DRAG LOCATION.
11:40	1km FROM LOCATION
* 11:50	7 O.T.B. FIX 405 E=624372.7 N=574086.2
13:00	PACIFIC CHALLENGER RELEASED FROM TOW BOWLE.
13:27	#3 P.C.P. PASSED TO P. CHALLENGER
13:00	SKYFIX CORRECTIONS STOPPED
* 14:12	3 O.T.B. @ 232' @ 2200 FT. - FIX 434
14:15	SKYFIX CORRECTION WORKING AGAIN. DIFF STUS WERE NOT SELECTED.
14:22	PACIFIC SHOGUN RELEASED FROM TOW BOWLE
14:39	#3 P.C.P. PASSED BACK TO PIG
14:57	PACIFIC SHOGUN RELEASED FROM TOW BOWLE
15:07	#6 P.C.P. PASSED TO PACIFIC CHALLENGER
15:21	#2 P.C.P. PASSED TO PACIFIC SHOGUN.
16:03	6 O.T.B. FIX 457 (P. CHALLENGER)
16:08	2 O.T.B. FIX 459 (P. SHOGUN)
16:19	6 SHOGUN + 2 SHOGUN
16:53	RE-RUNNING #2 + #6
17:20	2 O.T.B. (2nd TIME) FIX 475 (P. SHOGUN)
17:42	6 O.T.B. (2nd TIME) FIX 460 (P. CHALLENGER)
19:06	1 O.T.B. FIX 498 (P. SHOGUN)
19:32	5 O.T.B. FIX 504 (P. CHALLENGER)

forms are to be completed daily in duplicate on all vessels. Each form should be countersigned by the Clients Representative, the original being retained on board until the next crew change or at the end of job, whichever is the earlier, when they should be returned to the PERTH office.

Signature: *[Handwritten Signature]*
Well Completion Engineer

WHITE : Accounts Department
 BLUE : Operations Department
 YELLOW : Clients Representative

Signature: *[Handwritten Signature]*
CLIENT REPRESENTATIVE



RACAL SURVEY AUSTRALIA LIMITED

DAILY RECORD SHEET 903058 319

Date: 11/10/99 Client: CULCUS Job No.: 2930 A3 Vessel: S/S 20107 Location: BALEEN 2

PAGE 10 OF 10

Table with columns: Equipment, Op. Rows include SkyFix, LandStar, Gyro, PCGNS, MultiFix II, GRREP, SkyTrac.

Table with columns: Equipment, Op. Rows include Deso Echo Sounder, Sidescan, Boomer, Heave Co., STD-12, ENSIN.

Table with columns: Racal Personnel, Client Personnel. Names: T. LANGLEY, C. WAKELING, D. WILKINSON, S. LEWIS.

Table with columns: WX, Sea State, Swell, Wind Dir. Rows for 0000, 0600, 1200, 1800.

DIARY OF OPERATIONS

Table with columns: TIME, Time Zone = UTC+. Contains handwritten diary entries from 00:06 to 14:30, including details of magnetic declination measurements and final fix.

Forms are to be completed daily in duplicate on all vessels. Each form should be countersigned by the Clients Representative, the original being retained on board until the next crew change or at the end of job, whichever is the earlier, when they should be returned to the PERTH office.

Signature [Handwritten Signature] Well Completion Report SUPERVISOR/ENGINEER

WHITE : Accounts Department
BLUE : Operations Department
YELLOW : Clients Representative

Signature [Handwritten Signature] W. Edmund CLIENT REPRESENTATIVE VIC/RL5 Baleen 2

Cultus Petroleum DAILY DRILLING REPORT

WELL: BALEEN #2
 PERMIT: VIC/RL5
 RIG: SEDCO 702

DATE: 10.10.99
 REPORT # 1
 D.F.S. 0

DEPTH 2400 Hrs: STATUS @ 2400 Hrs: Tension anchors and obtain final position.
 TVD: FORMATION: Gippsland Limestone.
 24 HR PROGRESS: LAST CASING: @ SHOE L.O.T.:
 HOLE SIZE: WD (MSL): 55 RT - SEABED/MSL: 81 MAASP:
 SURVEYS:

MUD PROPERTIES		ADDITIVES	SOLIDS CONTROL			FORMATION DATA		
DENSITY(ppg)	8.6	Aquagel 369sx		lpm	uf	hrs	DEPTH	
VISCOSITY(Sees)	109	Dextrid 14sx	DESILTER				TRIP GAS (%)	
pH	9.7	EZ mud DP 3sx	DESANDER				CONN. GAS (%)	
PV/YP(cp/lb/100ft2)	18/50	Pac R 6sx	MUD CLEANER				B'GRD GAS (%)	
GELS 10/10	32/48	XCD Poly 5sx	CENTRIFUGE				PORE PRESS (SG)	
WL API(cc/30min)		Barite 263sx		1	2	3	ECD (SG)	
WL HTHP(cc/30min)		Caustic 5sx	SHAKERS				LITHOLOGY	
CAKE(mm)		Lime 8sx	SCREENS				DRILLS / BOPS	
SOLIDS %		Soda ash 2	PUMPS	1	2	3	LAST BOP DRILL	
SAND %			TYPE	A1700PT	A1700PT	A1700PT	LAST FIRE DRILL	
CHLORIDES(mg/l)			STROKE(in)	12	12	12	LAST MOB DRILL	
KCL %			LINER(in)	6	6	6	LAST ABN. RIG DRILL	10.10.99
MBT(lb/bbl)			SPM				LAST BOP TEST	9.10.99
TEMP °C			LPM				BOP TEST DUE	23.10.99
HOLE VOL(m3/bbl)			AV-DP(m/min)					HRS
SURF VOL(m3/bbl)			AV-DC(m/min)				1. MOVE RIG	12
LOSSES(m3/bbl/hr)			SPP(kPa/psi)				2. RUN ANCHORS	12
MUD Co	Baroid		SCR @ 40				3. DRILLING	
MUD TYPE	Spud		SCR @ 50				4. TRIP	

BIT DATA		WEATHER / RIG RESPONSE		
BIT No.	1	WIND SPEED(kts)	10/15	
SIZE(mm/in)	36	DIRECTION(°)	200	
TYPE	HO	TEMPERATURE(°C)	10	
IADC CODE		BAR. PRESSURE(kPa)	1006	
SERIAL No.		BAR. RISE / FALL(kPa)		
NOZZLES(32in)	20 x 3	VISIBILITY(NM)	5	
DEPTH IN (m)		WEATHER STATE	CALM	
DEPTH OUT (m)		SWELL / PER / DIR(m/sec*)	SW/1/11	
DRILLED (m cum/dly)		WAVES / PER / DIR(m/sec*)		
HOURS (cum/dly)		HEAVE(m)		
GRADE		PITCH(°)		
AVGE ROP (m/hr)		ROLL(°)		
WOB (mt)		ANCHOR TENSION-MIN(MT)	250	
RPM		ANCHOR TENSION-MAX(MT)	350	
JET VEL (m/sec)		RISER TENSION(MT)		
HHP @ BIT		VARIABLE DECK LOAD(MT)	2132	
BHA No.		BHA WEIGHT		STRING WT

DOWNHOLE TOOLS	SERIAL No.	ROT/REAM HRS	DRILLING DATA		
DRILLING JAR			DRAG - UP (mt)		25. ABDN /SUSPEND
DRILLING JAR			DRAG - DOWN (mt)		26. RIG SERVICE
SHOCK SUB			TORQUE-On Bottom (amps)		27. SLIP/CUT LINE
PDM			TORQUE-Off Bottom (amps)		28. PULL ANCHORS
					29.
					TOTAL (HRS) 24 0

Cultus Petroleum DAILY DRILLING REPORT

WELL: BALEEN #2
 PERMIT: VIC/RL5
 RIG: SEDCO 702

DATE: 11.10.99
 REPORT #: 2
 D.F.S.: 1

DEPTH 2400 Hrs: 137m STATUS @ 2400 Hrs: Drill ahead.
 TVD: 137m FORMATION: Gippsland Limestone.
 24 HR PROGRESS: 11m LAST CASING: 30" x 20" @ 126m SHOE L.O.T.:
 HOLE SIZE: 12 1/4" WD (MSL): 55 RT - SEABED/MSL: 81 MAASP:
 SURVEYS: 1/4° @ 126m. 1/2° @ 310m

MUD PROPERTIES		ADDITIVES	SOLIDS CONTROL			FORMATION DATA			
DENSITY(ppg)	8.6	Aquagel 89 sx	lpm	uf	hrs	DEPTH			
VISCOSITY(Sees)	103	Barite 144 sx	DESILTER			TRIP GAS (%)			
pH	10.5	CaCl 14 sx	DESANDER			CONN. GAS (%)			
PV/YP(cp/lb/100ft2)	12/42	NaOH 9 sx	MUD CLEANER			B'GRD GAS (%)			
GELS 10/10	24/38	Lime 5 sx	CENTRIFUGE			PORE PRESS (SG)			
WL API(cc/30min)				1	2	3	ECD (SG)		
WL HTHP(cc/30min)			SHAKERS	Thule	Thule	Thule	LITHOLOGY		
CAKE(mm)			SCREENS	52/120	52/120	52/120	DRILLS / BOPS		
SOLIDS %			PUMPS	1	2	3	LAST BOP DRILL		
SAND %			TYPE	A1700PT	A1700PT	A1700PT	LAST FIRE DRILL		
CHLORIDES(mg/l)			STROKE(in)	12	12	12	LAST MOB DRILL		
KCL %			LINER(in)	6"	6"	6"	LAST ABN. RIG DRILL	10.10.99	
MBT(lb/bbl)			SPM	100	100	100	LAST BOP TEST	9.10.99	
TEMP °C			GPM	367	367	367	BOP TEST DUE	23.10.99	
HOLE VOL(m3/bbl)			AV-DP(ft/min)	82				HRS	CUM
SURF VOL(m3/bbl)			AV-DC(ft/min)	109			1. MOVE RIG		81.5
LOSSES(m3/bbl/hr)			SPP(kPa/psi)				2. RUN ANCHORS	2	14
MUD Co	Baroid		SCR @ 40				3. DRILLING	4.25	4.25
MUD TYPE	Spud		SCR @ 50				4. TRIP	8.5	8.5
BIT DATA			WEATHER / RIG RESPONSE			5. WIPER TRIP			
BIT No.	RR2	3	WIND SPEED(kts)	25			6. SURVEY		
SIZE(mm/in)	17 1/2"	12 1/4"	DIRECTION(°)	250°			7. CIRC./COND		
TYPE	Msdsshqc	DS40H	TEMPERATURE(°C)	14-16			8. HANDLE BHA		
IADC CODE	137	PDC	BAR. PRESSURE(kPa)	1008			9. CASE/CEMENT		
SERIAL No.	LF9226	10452	BAR. RISE / FALL(kPa)	+2			10. WELLHEAD		
NOZZLES(32n)	24 x 3	18 x 5	VISIBILITY(NM)	12			11. BOPS		
DEPTH IN (m)	120	126	WEATHER STATE	Fair			12. LOT		
DEPTH OUT (m)	126	Rng	SWELL / PER / DIR(m/sec*)	250/1/11			13. CORING		
DRILLED (m cum/dty)	Ream cmt	11	WAVES / PER / DIR(m/sec*)	250/3/3			14. LOGGING		
HOURS (cum/dty)	2	1/2	HEAVE(m)	.3 x 9			15. REAM/WASH		
GRADE	11WTAEWTTD	Rng	PITCH(°)	4 x 6			16. FISH/STUCK		
AVGE ROP (m/hr)	3.0	5.0	ROLL(°)	.3 x 5			17. LOSS CIRC		
WOB (mt)	5	5	ANCHOR TENSION-MIN(MT)	210			18. KICK CONTROL		
RPM	70	110	ANCHOR TENSION-MAX(MT)	270			19. SIDETRACK		
JET VEL (ft/sec)		295	RISER TENSION(MT)	0			20. OTHER		
HHP @ BIT		444	VARIABLE DECK LOAD(MT)	1986			21. REP. SURF		
BHA No.	2	BHA WEIGHT	50kibs	STRING WT	70kibs			22. WELL TEST	
BHA Profile :			Bit.NB Stab Anderdrift.Stab.NMDC.Stab.10 x 8" LSW Dc Xo.15HWDP.			23. WO WEATHER			
						24. WAIT - CEMENT			
						1.25			
						1.25			
DOWNHOLE TOOLS	SERIAL No.	ROT/REAM HRS	DRILLING DATA			25. ABDN./SUSPEND			
Anderdrift	DOT 42241		DRAG - UP (mt)	0			26. RIG SERVICE		
NMDC	94002		DRAG - DOWN (mt)	0			0.5		
Stab	DOT3212		TORQUE-On Bottom (amps)	100			27. SLIP/CUT LINE		
NB Stab	DOT 3209		TORQUE-Off Bottom (amps)	100			28. PULL ANCHORS		
Stab	DOT 21094					29			
						1			
						1			
						TOTAL (HRS)			
						24			
						117.5			

Cultus Petroleum DAILY DRILLING REPORT

WELL: BALEEN #2
 PERMIT: VIC/RL5
 RIG: SEDCO 702

DATE: 12.10.99
 REPORT #: 3
 D.F.S.: 2

DEPTH 2400 Hrs: 650 STATUS @ 2400 Hrs: P/u 18 3/4" wellhead housing.
 TVD: 650 FORMATION: Lakes Entrance.
 24 HR PROGRESS: 513 LAST CASING: 30" x 20" @ 126m SHOE L.O.T.:
 HOLE SIZE: 12 1/4" WD (MSL): 55 RT - SEABED/MSL: 81 MAASP:
 SURVEYS: 1/2° @ 252m. 1/2° @ 397m. 1/2° @ 513m. 1/2° @ 597m. 1/4° @ 650m.

MUD PROPERTIES		ADDITIVES	SOLIDS CONTROL			FORMATION DATA		
DENSITY(ppg)	8.7	Aquagel 144 sx	lpm	uf	hrs	DEPTH		
VISCOSITY(Sees)	171	NaOH 1 sx	DESILTER			TRIP GAS (%)		
pH	10.8	Lime 3 sx	DESANDER			CONN. GAS (%)		
PV/YP(cp/lb/100ft2)	28/62		MUD CLEANER			B'GRD GAS (%)		
GELS 10/10	58/66		CENTRIFUGE			PORE PRESS (SG)		
WL API(cc/30min)				1	2	3	ECD (SG)	
WL HTHP(cc/30min)			SHAKERS	Thule	Thule	Thule	LITHOLOGY	
CAKE(mm)			SCREENS	52/120	52/120	52/120	DRILLS / BOPS	
SOLIDS %			PUMPS	1	2	3	LAST BOP DRILL	
SAND %			TYPE	A1700PT	A1700PT	A1700PT	LAST FIRE DRILL	
CHLORIDES(mg/l)			STROKE(in)	12	12	12	LAST MOB DRILL	
KCL %			LINER(in)	6'	6'	6'	LAST ABN. RIG DRILL	10.10.99
MBT(lb/bbl)			SPM				LAST BOP TEST	9.10.99
TEMP °C			GPM				BOP TEST DUE	23.10.99
HOLE VOL(m3/bbl)			AV-DP(ft/min)					HRS
SURF VOL(m3/bbl)			AV-DC(ft/min)				1. MOVE RIG	CUM
LOSSES(m3/bbl/hr)			SPP(kPa/psi)				2. RUN ANCHORS	81.5
MUD Co	Baroid		SCR @ 40				3. DRILLING	11.5
MUD TYPE	Spud		SCR @ 50				4. TRIP	5
							5. WIPER TRIP	
							6. SURVEY	0.5
							7. CIRC./COND	1
							8. HANDLE BHA	
							9. CASE/CEMENT	5.75
							10. WELLHEAD	10.75
							11. BOPS	
							12. LOT	
							13. CORING	
							14. LOGGING	
							15. REAM/WASH	2
							16. FISH/STUCK	
							17. LOSS CIRC	
							18. KICK CONTROL	
							19. SIDETRACK	
							20. JHA	0.25
							21. REP SURF	
							22. WELL TEST	
							23. WO WEATHER	
							24. WAIT - OTHER	
							25. ABDN./SUSPEND	
							26. RIG SERVICE	0.5
							27. SLIP/CUT LINE	
							28. PULL ANCHORS	
							29. DRILL	1
							TOTAL (HRS)	24
								141.25

DOWNHOLE TOOLS	SERIAL No.	ROT/REAM HRS	DRILLING DATA
Anderdrift	DOT 42241	14	DRAG - UP (mt) 0
NMDC	94002	14	DRAG - DOWN (mt) 0
Slab	DOT3212	14	TORQUE-On Bottom (amps) 0
NB Slab	DOT 3209	14	TORQUE-Off Bottom (amps) 0
Slab	DOT 21094	14	

Cultus Petroleum DAILY DRILLING REPORT

WELL: BALEEN #2
 PERMIT: VIC/RL5
 RIG: SEDCO 702

DATE: 13.10.99
 REPORT # 4
 D.F.S. 3

DEPTH 2400 Hrs: 650 STATUS @ 2400 Hrs: POOH with BOP test plug
 TVD: 650 FORMATION: Lakes Entrance
 24 HR PROGRESS: 0 LAST CASING: 9-5/8" @ 646m SHOE L.O.T.:
 HOLE SIZE: 12 1/4" WD (MSL): 55 RT - SEABED/MSL: 81 MAASP:
 SURVEYS:

MUD PROPERTIES		ADDITIVES	SOLIDS CONTROL			FORMATION DATA		
DENSITY(ppg)	10.1	Dextrid Light 26sx		lpm	uf	hrs	DEPTH	
VISCOSITY(Sees)	47	EZ mud DP 3sx	DESILTER				TRIP GAS (%)	
pH	9.6	Pac R 8sx	DESANDER				CONN. GAS (%)	
PV/YP(cp/lb/100ft2)	16/26	NaCl 7248 kg	MUD CLEANER				B'GRD GAS (%)	
GELS 10/10	4/6	XCD 6 sx	CENTRIFUGE				PORE PRESS (SG)	
WL API(cc/30min)	4	Barite 190 sx		1	2	3	ECD (SG)	
WL HTHP(cc/30min)	18	NaOH 2 pail	SHAKERS	Thule	Thule	Thule	LITHOLOGY	
CAKE(mm)	1/2	Soda ash 1sx	SCREENS	52/120	52/120	52/120	DRILLS / BOPS	
SOLIDS %	5.1		PUMPS	1	2	3	LAST BOP DRILL	
SAND %	Nil		TYPE	A1700PT	A1700PT	A1700PT	LAST FIRE DRILL	
CHLORIDES(mg/l)	51000		STROKE(in)	12	12	12	LAST MOB DRILL	
NaCl %	8		LINER(in)	6*	6*	6*	LAST ABN. RIG DRILL	
MBT(lb/bbl)	0		SPM				LAST BOP TEST	
TEMP °C	16		GPM				BOP TEST DUE	
HOLE VOL(m3/bbl)	630		AV-DP(ft/min)					HRS
SURF VOL(m3/bbl)	846		AV-DC(ft/min)				1. MOVE RIG	CUM
LOSSES(m3/bbl/hr)	0		SPP(kPa/psi)				2. RUN ANCHORS	
MUD Co	Baroid		SCR @ 40				3. DRILLING	15.75
MUD TYPE	Spud		SCR @ 50				4. TRIP	3
							5. WIPER TRIP	16

BIT DATA		WEATHER / RIG RESPONSE		
BIT No.		WIND SPEED(kts)	15	
SIZE(mm/in)		DIRECTION(°)	040°	
TYPE		TEMPERATURE(°C)	15 - 18	
IADC CODE		BAR. PRESSURE(kPa)	1009	
SERIAL No.		BAR. RISE / FALL(kPa)	-4	
NOZZLES(32in)		VISIBILITY(NM)	8	
DEPTH IN (m)		WEATHER STATE	o'cast / calm	
DEPTH OUT (m)		SWELL / PER / DIR(m/sec°)	1/11/220	
DRILLED (m cum/dly)		WAVES / PER / DIR(m/sec°)	1/04/40	
HOURS (cum/dly)		HEAVE(m)	3 x 10	
GRADE		PITCH(°)	2 x 4	
AVGE ROP (m/hr)		ROLL(°)	2 x 5	
WOB (mt)		ANCHOR TENSION-MIN(MT)	200	
RPM		ANCHOR TENSION-MAX(MT)	300	
JET VEL (ft/sec)		RISER TENSION(MT)	280	
HHP @ BIT		VARIABLE DECK LOAD(MT)	1845	

BHA No.		BHA WEIGHT		STRING WT		22. WELL TEST	
BHA Profile :						23. WO WEATHER	
						24. WAIT - OTHER	
DOWNHOLE TOOLS	SERIAL No.	ROT/REAM HRS	DRILLING DATA			25. ABDN /SUSPEND	
			DRAG - UP (mt)	0		26. RIG SERVICE	0.5
			DRAG - DOWN (mt)	0		27. SLIP/CUT LINE	
			TORQUE-On Bottom (amps)	0		28. PULL ANCHORS	
			TORQUE-Off Bottom (amps)	0		29. DRILLS	1
						TOTAL (HRS)	24
							165.25

Cultus Petroleum DAILY DRILLING REPORT

WELL: BALEEN #2
 PERMIT: VIC/RL5
 RIG: SEDCO 702

DATE: 14.10.99
 REPORT # 5
 D.F.S. 4

DEPTH 2400 Hrs: 746 STATUS @ 2400 Hrs: POOH to P/u core barrel.
 TVD: 746 FORMATION: Lakes Entrance.
 24 HR PROGRESS: 96 LAST CASING: 9-5/8" @ 646m SHOE L.O.T.: 15.1
 HOLE SIZE: 8 1/2" WD (MSL): 55 RT - SEABED/MSL: 81 MAASP: 560

SURVEYS:

MUD PROPERTIES		ADDITIVES	SOLIDS CONTROL			FORMATION DATA			
DENSITY(ppg)	10.1	Nitrate 3sx	ipm	uf	hrs	DEPTH	746m		
VISCOSITY(Sees)	49	EZ mud DP 11sx	DESILTER			TRIP GAS (%)			
pH	9.4	Pac R 1sx	DESANDER			CONN. GAS (%)			
PV/YP(cp/lb/100ft ²)	16/22	Soda ash 1sx	MUD CLEANER			B'GRD GAS (%)	1.19%		
GELS 10/10	5/8	Barite 50 sx	CENTRIFUGE			PORE PRESS (SG)			
WL API(cc/30min)	3.8	Dextrid LIGHT 2sx		1	2	ECD (ppg)	10.8		
WL HTHP(cc/30min)	16.8	XCD 2 sx	SHAKERS	Thule	Thule	LITHOLOGY			
CAKE(mm)	1/2		SCREENS	52/120	52/120	DRILLS / BOPS			
SOLIDS %	5.5		PUMPS	1	2	3	LAST BOP DRILL		
SAND %	5		TYPE	A1700PT	A1700PT	A1700PT	LAST FIRE DRILL		
CHLORIDES(mg/l)	51000		STROKE(in)	12	12	12	LAST MOB DRILL		
NaCl %	8		LINER(in)	6"	6"	6"	LAST ABN. RIG DRILL 10.10.99		
MBT(lb/bbl)	.6		SPM	75	75		LAST BOP TEST 9.10.99		
TEMP °C	27		GPM	317	317		BOP TEST DUE 23.10.99		
HOLE VOL(bbl)	220		AV-DP(ft/min)	259				HRS	CUM
SURF VOL(m ³ /bbl)	484		AV-DC(ft/min)	518			1. MOVE RIG		81.5
LOSSES(m ³ /bbl/hr)	Nil to hole.		SPP(psi)	1600			2. RUN ANCHORS		14
MUD Co	Baroid		SCR @ 30	100	CLF	25	3. DRILLING	11.25	27
MUD TYPE	NaCl / PhPa		SCR @ 50	225	CLF	75	4. TRIP	6.25	22.25
BIT DATA			WEATHER / RIG RESPONSE			5. WIPER TRIP			
BIT No	4		WIND SPEED(kts)	15			6. SURVEY 0.5		
SIZE(mm/in)	8 1/2"		DIRECTION(°)	050°			7. CIRC./COND 1 3.25		
TYPE	MHT13G		TEMPERATURE(°C)	14 - 20			8. HANDLE BHA 1.5 1.5		
IADC CODE	1.3.7		BAR. PRESSURE(kPa)	1007			9. CASE/CEMENT 15.5		
SERIAL No	KT2055		BAR. RISE / FALL(kPa)	-2			10. WELLHEAD		
NOZZLES(32n)	18 x 3		VISIBILITY(NM)	12			11. BOPS 16.25		
DEPTH IN (m)	650		WEATHER STATE	clear / calm			12. LOT 0.5 0.5		
DEPTH OUT (m)	746		SWELL / PER / DIR(m/sec°)	1/11/160			13. CORING		
DRILLED (m cum/dly)	96		WAVES / PER / DIR(m/sec°)	1/04/50			14. LOGGING		
HOURS (cum/dly)	11 1/4		HEAVE(m)	2 x 10			15. REAM/WASH 3.25 5.25		
GRADE	23WTOE1WTCP		PITCH(°)	2 x 6			16. FISH/STUCK		
AVGE ROP (m/hr)	8.5		ROLL(°)	2 x 5			17. LOSS CIRC		
WOB (mt)	10 - 15		ANCHOR TENSION-MIN(MT)	200			18. KICK CONTROL		
RPM	70 - 110		ANCHOR TENSION-MAX(MT)	300			19. SIDETRACK		
JET VEL (ft/sec)	273		RISER TENSION(MT)	280			20. JHA		
HHP @ BIT	249		VARIABLE DECK LOAD(MT)	1702			21. REP. SURF		
BHA No.	4	BHA WEIGHT	37000	STRING WT	63000		22. WELL TEST		
BHA Profile:			Bit Bit sub 2 Dc x 6 1/4 Xo Stab. Xo 10 Dc x 6 1/4 Xo Jars Xo 3Dc Xo 15 HWDP.				23. WO WEATHER		
							24. Function test 0.25 0.25		
DOWNHOLE TOOLS	SERIAL No.	ROT/REAM HRS	DRILLING DATA			25. ABDN./SUSPEND			
Stab	207000049	11 1/4	DRAG - UP (mt)	0			26. RIG SERVICE 0.5		
Dailey Jars	1416-1072	11 1/4	DRAG - DOWN (mt)	0			27. SLIP/CUT LINE		
			TORQUE-On Bottom (amps)	100			28. PULL ANCHORS		
			TORQUE-Off Bottom (amps)	100			29. DRILLS 1		
						TOTAL (HRS)	24	189.25	

Cultus Petroleum DAILY DRILLING REPORT

WELL: BALEEN #2
 PERMIT: VIC/RL5
 RIG: SEDCO 702

DATE: 15.10.99
 REPORT # 6
 D.F.S. 5

DEPTH 2400 Hrs: 780 STATUS @ 2400 Hrs: POOH w/ core #2.
 TVD: 780 FORMATION: Gurnard.
 24 HR PROGRESS: 34 LAST CASING: 9-5/8" @ 646m SHOE L.O.T.: 15.1
 HOLE SIZE: 8 1/2" WD (MSL): 55 RT - SEABED/MSL: 81 MAASP: 560

SURVEYS:

MUD PROPERTIES		ADDITIVES	SOLIDS CONTROL			FORMATION DATA			
DENSITY(ppg)	10.1	NaOH 2 sx		lpm	uf	hrs	DEPTH	762m 746m	
VISCOSITY(Sees)	52	Soda ash 1sx	DESILTER				Total Gas (%)	4% 1%	
pH	8.8	XCD 1 sx	DESANDER				C1 ppm	12200 25600	
PVYP(cp/lb/100ft2)	18/25		MUD CLEANER				C2 ppm	145	
GELS 10/10	4/6		CENTRIFUGE				PORE PRESS (SG)		
WL API(cc/30min)	3.7			1	2	3	ECD (ppg)	10.8	
WL HTHP(cc/30min)	15.4		SHAKERS	Thule	Thule	Thule	LITHOLOGY	sst sandstone	
CAKE(mm)	1/2		SCREENS	52/120	52/120	52/120	DRILLS / BOPS		
SOLIDS %	6.8		PUMPS	1	2	3	LAST BOP DRILL		
SAND %	35		TYPE	A1700PT	A1700PT	A1700PT	LAST FIRE DRILL		
CHLORIDES(mg/l)	47000		STROKE(in)	12	12	12	LAST MOB DRILL		
NaCL %	7.7		LINER(in)	6'	6'	6'	LAST ABN. RIG DRILL	10.10.99	
MBT(lb/bbl)	.9		SPM	45			LAST BOP TEST	9.10.99	
TEMP °C	29		GPM	190			BOP TEST DUE	23.10.99	
HOLE VOL(bbl)	220		AV-DP(ft/min)	77				HRS CUM	
SURF VOL(m3/bbl)	484		AV-DC(ft/min)	155			1. MOVE RIG	81.5	
LOSSES(m3/bbl/hr)	Nil to hole.		SPP(psi)	550			2. RUN ANCHORS	14	
MUD Co	Baroid		SCR @ 20	200	CLF		3. DRILLING	6.5 33.5	
MUD TYPE	NaCl / PhPa		SCR @ 30	325	CLF		4. TRIP	15.75 38	
BIT DATA			WEATHER / RIG RESPONSE			5. WIPER TRIP			
BIT No.	RR5		WIND SPEED(kts)	22			6. SURVEY	0.5	
SIZE(mm/in)	8 1/2"		DIRECTION(°)	280°			7. CIRC./COND	1.75 5	
TYPE	CD73		TEMPERATURE(°C)	15 - 17			8. HANDLE BHA	1.5	
IADC CODE	Core head		BAR. PRESSURE(kPa)	1013			9. CASE/CEMENT	15.5	
SERIAL No.	7970238		BAR. RISE / FALL(kPa)	+6			10. WELLHEAD		
NOZZLES(32in)	TFA		VISIBILITY(NM)	12			11. BOPS	16.25	
DEPTH IN (m)	746		WEATHER STATE	O'cast			12. LOT	0.5	
DEPTH OUT (m)	763		SWELL / PER / DIR(m/sec*)	1/11/250			13. CORING		
DRILLED (m cum/dy)	17		WAVES / PER / DIR(m/sec*)	1.5/3/280			14. LOGGING		
HOURS (cum/dy)	2		HEAVE(m)	3 x 10			15. REAM/WASH	5.25	
GRADE	12CTSx1BPPR		PITCH(°)	.2 x 6			16. FISH/STUCK		
AVGE ROP (m/hr)	8.5		ROLL(°)	3 x 6			17. LOSS CIRC		
WOB (mt)	5		ANCHOR TENSION-MIN(MT)	200			18. KICK CONTROL		
RPM	70		ANCHOR TENSION-MAX(MT)	310			19. SIDETRACK		
JET VEL (ft/sec)			RISER TENSION(MT)	280			20. JHA		
HHP @ BIT			VARIABLE DECK LOAD(MT)	1734			21. REP. SURF		
BHA No.	5	BHA WEIGHT	37000	STRING WT	63000			22. WELL TEST	
BHA Profile : Core head Core barrel x18m. Xo. Circ sub. 9 x 6 1/4 Dc Xo. Jars Xo. Circ sub 3 x 6Dc. Xo 1x HWDP. Dart sub. 14 x HWDP.									
DOWNHOLE TOOLS	SERIAL No.	ROT/REAM HRS	DRILLING DATA			25. ABDN /SUSPEND			
			DRAG - UP (mt)	0			26. RIG SERVICE	0.5	
Dailey Jars	1416-1072	11%	DRAG - DOWN (mt)	0			27. SLIP/CUT LINE		
			TORQUE-On Bottom (amps)	100			28. PULL ANCHORS		
			TORQUE-Off Bottom (amps)	100			29. DRILLS	1	
							TOTAL (HRS)	24 213.25	

Cultus Petroleum DAILY DRILLING REPORT

WELL:	BALEEN #2	DATE:	16.10.99
PERMIT:	VIC/RL5	REPORT #	7
RIG:	SEDCO 702	D.F.S.	6

DEPTH 2400 Hrs:	895	STATUS @ 2400 Hrs:	Schlumberger log.
TVD:	895	FORMATION:	Strzelecki
24 HR PROGRESS:	115	LAST CASING:	9-5/8" @ 646m
HOLE SIZE:	8 1/2"	WD (MSL):	55
		RT - SEABED/MSL:	81
		SHOE L.O.T.:	15.1
		MAASP:	560

SURVEYS:

MUD PROPERTIES		ADDITIVES	SOLIDS CONTROL			FORMATION DATA			
DENSITY(ppg)	10.1	Dextrid 8 sx		bm	uf	hrs	DEPTH	870m	887m
VISCOSITY(Secs)	53	Pac-R 3 sx	DESILTER				Total Gas (%)	0.35%	0.41%
pH	8.9	NaCl 2035 kg	DESANDER				C1 ppm	3200	4600
PV/VP(cc/lb/100ft2)	18/26	XCD 3 sx	MUD CLEANER				C2 ppm		
GELS 10/10	5/6	Barite 100 sx	CENTRIFUGE				PORE PRESS (SG)		
WL API(cc/30min)	3.2	Caustic 2 pail		1	2	3	ECD (ppg)	11.1 @ TD	
WL HTHP(cc/30min)	15	Soda Ash 1 sx	SHAKERS	Thule	Thule	Thule	LITHOLOGY	sst	sandstone
CAKE(mm)	1/2	Nitrate 1 sx	SCREENS	52/120	52/120	52/120	DRILLS / BOPS		
SOLIDS %	6.4		PUMPS	1	2	3	LAST BOP DRILL		
SAND %	55		TYPE	A1700PT	A1700PT	A1700PT	LAST FIRE DRILL		
CHLORIDES(mg/l)	47000		STROKE(in)	12	12	12	LAST MOB DRILL		
NaCl %	7.2		LINER(in)	6"	6"	6"	LAST ABN. RIG DRILL		
MBT(lb/bbl)	1.0		SPM	70	70		LAST BOP TEST		
TEMP °C	28		GPM	300	300		BOP TEST DUE		
HOLE VOL(bbl)	284		AV-DP(ft/min)	242				HRS	CUM
SURF VOL(m3/bbl)	601		AV-DQ(ft/min)	483			1. MOVE RIG		
NITRATE ppm	440 / 400		SPP(psi)	2300			2. RUN ANCHORS		
MUD Co	Baroid		SCR @ 30	130	130		3. DRILLING		
MUD TYPE	NaCl / PhPa		SCR @ 50	225	225		4. TRIP		

BIT DATA			WEATHER / RIG RESPONSE		
BIT No.	6	5rr	WIND SPEED(kts)	10	
SIZE(mm/in)	8 1/2"	8 1/2"	DIRECTION(*)	40°	
TYPE	HP43LK	CD73	TEMPERATURE(°C)	14 - 17	
IADC CODE	437	Core head	BAR. PRESSURE(kPa)	1017	
SERIAL No.	QD4605	7970238	BAR. RISE / FALL(kPa)	+4	
NOZZLES(32in)	14 x 3	TFA	VISIBILITY(NM)	12	
DEPTH IN (m)	780.3	762.3	WEATHER STATE	Clear	
DEPTH OUT (m)	895	780.3	SWELL / PER / DIR(m/sec*)	.5/11/200	
DRILLED (m cum/dly)	114.7	18	WAVES / PER / DIR(m/sec*)	1/03/40	
HOURS (cum/dly)	6	1	HEAVE(m)	2 x 9	
GRADE	11NAE1NTD	12CTSX1BPPR	PITCH(*)	2 x 6	
AVGE ROP (m/hr)	19	18.0	ROLL(*)	2 x 5	
WOB (mt)	15 - 20	5	ANCHOR TENSION-MIN(MT)	200	
RPM	90	70	ANCHOR TENSION-MAX(MT)	300	
JET VEL (ft/sec)	421		RISER TENSION(MT)	274	
HHP @ BIT	552		VARIABLE DECK LOAD(MT)	1762	
BHA No.	6	BHA WEIGHT	37000	STRING WT	70000

DOWNHOLE TOOLS	SERIAL No.	ROT/REAM HRS	DRILLING DATA	
Nb STAB	3229	6	DRAG - UP (mt)	0
Daley Jars	1416-1072	23%	DRAG - DOWN (mt)	0
STAB x 2	000049/2072256	17% / 6	TORQUE-On Bottom (amps)	100
PONY NMDC	9612058	6	TORQUE-Off Bottom (amps)	100
NMDC	L-955	6	TOTAL (HRS)	24
				237.25

#VALUE!

Cultus Petroleum DAILY DRILLING REPORT

WELL:	BALEEN #2	DATE:	17.10.99
PERMIT:	VIC/RL5	REPORT #	8
RIG:	SEDCO 702	D.F.S.	7

DEPTH 2400 Hrs:	895	STATUS @ 2400 Hrs:	Schlumberger POOH w/ MDT.
TVD:	895	FORMATION:	Strzelecki
24 HR PROGRESS:	0	LAST CASING:	9-5/8" @ 646m
HOLE SIZE:	8 1/2"	WD (MSL):	55
		RT - SEABED/MSL:	81
		SHOE L.O.T.:	15.1
		MAASP:	560

SURVEYS: Deviation less than 1/2° over open hole section. Azimuth indeterminate.

MUD PROPERTIES		ADDITIVES	SOLIDS CONTROL			FORMATION DATA		
DENSITY(ppg)	10.1	Baracide 1 can		pm	uf	hrs	DEPTH	
VISCOSITY(Sees)	50	NaCl 20000 kg	DESILTER				Total Gas (%)	
pH	9.0	CaCl 2 sx	DESANDER				C1 ppm	
PV/VP(cc/lb/100ft2)	17/25	NaOH 1 pail	MUD CLEANER				C2 ppm	
GELS 10/10	5/7		CENTRIFUGE				PORE PRESS (SG)	
WL AP(cc/30min)	3.6			1	2	3	ECD (ppg)	
WL HTHP(cc/30min)	15.4		SHAKERS	Thule	Thule	Thule	LITHOLOGY	
CAKE(mm)	1/2		SCREENS	52/120	52/120	52/120	DRILLS / BOPS	
SOLIDS %	6.2		PUMPS	1	2	3	LAST BOP DRILL	16.10.99
SAND %	.5		TYPE	A1700PT	A1700PT	A1700PT	LAST FIRE DRILL	
CHLORIDES(mg/l)	46500		STROKE(in)	12	12	12	LAST MOB DRILL	
NaCl %	7.6		LINER(in)	6"	6"	6"	LAST ABN. RIG DRILL	10.10.99
MBT(lb/bbl)	1.0		SPM				LAST BOP TEST	9.10.99
TEMP °C	0		GPM				BOP TEST DUE	23.10.99
HOLE VOL(bbl)	284		AV-DP(ft/min)					HRS
Total Vol(bbl)	1162		AV-DQ(ft/min)					CUM
NITRATE ppm	400		SPP(psi)				1. MOVE RIG	81.5
MUD Co	Baroid		SCR @ 30				2. RUN ANCHORS	14
MUD TYPE	NaCl / PhPa		SCR @ 50				3. DRILLING	39.5
BIT DATA			WEATHER / RIG RESPONSE					
BIT No.			WIND SPEED(kts)	4			5. WIPER TRIP	0
SIZE(mm/in)			DIRECTION(°)	Var°			6. SURVEY	0.5
TYPE			TEMPERATURE(°C)	14 - 18			7. CIRC./COND	5.5
IADC CODE			BAR. PRESSURE(kPa)	1017			8. HANDLE BHA	1.5
SERIAL No.			BAR. RISE / FALL(kPa)	-6			9. CASE/CEMENT	15.5
NOZZLES(32n)			VISIBILITY(NM)	12			10. WELLHEAD	
DEPTH IN (m)			WEATHER STATE	Clear			11. BOPS	16.25
DEPTH OUT (m)			SWELL / PER / DIR(m/sec°)	5/11/100			12. LOT	0.5
DRILLED (cum/dly)			WAVES / PER / DIR(m/sec°)	1/03/40			13. CORING	2
HOURS (cum/dly)			HEAVE(m)	2 x 9			14. LOGGING	24 31
GRADE			PITCH(°)	2 x 4			15. REAMWASH	6.75
AVGE ROP (m/hr)			ROLL(°)	3 x 5			16. FISH/STUCK	
WOB (mt)			ANCHOR TENSION-MIN(MT)	210			17. LOSS CIRC	
RPM			ANCHOR TENSION-MAX(MT)	270			18. KICK CONTROL	
JET VEL (ft/sec)			RISER TENSION(MT)	280			19. SIDETRACK	
HHP @ BIT			VARIABLE DECK LOAD(MT)	1865			20. JHA	
BHA No.		BHA WEIGHT			STRING WT		21. REP. SURF	
BHA Profile :							22. WELL TEST	
							23. WO WEATHER	
							24. Function test	0.25
DOWNHOLE TOOLS		SERIAL No.	ROT/REAM HRS	DRILLING DATA				
				DRAG - UP (mt)			25. ABDN./SUSPEND	
				DRAG - DOWN (mt)			26. RIG SERVICE	0.5
				TORQUE-On Bottom (amps)			27. SLIP/CUT LINE	
				TORQUE-Off Bottom (amps)			28. PULL ANCHORS	
							29. DRILLS	1
							TOTAL (HRS)	24 261.25

28.75

Cultus Petroleum DAILY DRILLING REPORT

WELL:	BALEEN #2	DATE:	18.10.99
PERMIT:	VIC/RL5	REPORT #	9
RIG:	SEDCO 702	D.F.S.	8

DEPTH 2400 Hrs:	PBD 125m	STATUS @ 2400 Hrs:	All plugs in place. Prepare to pull BOP stack.	
TVD:	0	FORMATION:		
24 HR PROGRESS:	0	LAST CASING:	9-5/8"	@
HOLE SIZE:		WD (MSL):	55	RT - SEABED/MSL:
			81	SHOE L.O.T.:
				15.1
				MAASP:
				560

SURVEYS:

MUD PROPERTIES		ADDITIVES	SOLIDS CONTROL			FORMATION DATA		
DENSITY(ppg)	10.1		pm	uf	hrs	DEPTH		
VISCOSITY(Sees)	52		DESILTER			Total Gas (%)		
pH	9.5		DESANDER			C1 ppm		
PV/YP(cp/lb/100ft2)	18/26		MUD CLEANER			C2 ppm		
GELS 10/10	5/7		CENTRIFUGE			PORE PRESS (SG)		
WL API(cc/30min)	3.8			1	2	3	ECD (ppg)	
WL HTHP(cc/30min)	-		SHAKERS	Thule	Thule	Thule	LITHOLOGY	
CAKE(mm)	1		SCREENS	52/120	52/120	52/120	DRILLS / BOPS	
SOLIDS %	-		PUMPS	1	2	3	LAST BOP DRILL	16.10.99
SAND %	-		TYPE	A1700PT	A1700PT	A1700PT	LAST FIRE DRILL	
CHLORIDES(mg/l)	-		STROKE(in)	12	12	12	LAST MOB DRILL	
NaCl %	7.4		LINER(in)	6"	6"	6"	LAST ABN. RIG DRILL	10.10.99
MBT(lb/bbl)	-		SPM				LAST BOP TEST	9.10.99
TEMP °C	-		GPM				BOP TEST DUE	23.10.99
HOLE VOL(bbl)	-		AV-DP(ft/min)					
Total Vo(bbl)	878		AV-DQ(ft/min)					
NITRATE ppm	-		SPP(psi)					
MUD Co	Baroid		SCR @ 30					
MUD TYPE	NaCVPhPa		SCR @ 50					
BIT DATA			WEATHER / RIG RESPONSE			5. WIPER TRIP		
BIT No.			WIND SPEED(kts)	25		6. SURVEY		
SIZE(mm/in)			DIRECTION(°)	250°		7. CIRC/COND		
TYPE			TEMPERATURE(°C)	14 - 17		8. HANDLE BHA		
IADC CODE			BAR. PRESSURE(kPa)	1015		9. CASE/CEMENT		
SERIAL No.			BAR. RISE / FALL(kPa)	-2		10. WELLHEAD		
NOZZLES(32in)			VISIBILITY(NM)	12		11. BOPS		
DEPTH IN (m)			WEATHER STATE	Cbudy		12. LOT		
DEPTH OUT (m)			SWELL / PER / DIR(m/sec")	1.5/11/200		13. CORING		
DRILLED (cum/dly)			WAVES / PER / DIR(m/sec")	2.3/4/250		14. LOGGING		
HOURS (cum/dly)			HEAVE(m)	3 x 10		15. REAMWASH		
GRADE			PITCH(°)	.3 x 5		16. FISH/STUCK		
AVGE ROP (m/hr)			ROLL(°)	.2 x 5		17. LOSS CIRC		
WOB (mt)			ANCHOR TENSION-MIN(MT)	200		18. KICK CONTROL		
RPM			ANCHOR TENSION-MAX(MT)	280		19. SIDETRACK		
JET VEL (ft/sec)			RISER TENSION(MT)	266		20. JHA.		
HHP @ BIT			VARIABLE DECK LOAD(MT)	1958		21. REP SURF		
BHA No.		BHA WEIGHT		STRING WT		22. WELL TEST		
BHA Profile :						23. WO WEATHER		
						24. Function test		
						0.5		
						0.75		
DOWNHOLE TOOLS	SERIAL No.	ROT/REAM HRS	DRILLING DATA			25. ABANDON		
			DRAG - UP (mt)			2		
			DRAG - DOWN (mt)			2		
			TORQUE-On Bottom (amps)			26. RIG SERVICE		
			TORQUE-Off Bottom (amps)			0.5		
						27. SLIP/CUT LINE		
						28. PULL ANCHORS		
						29. DRILLS		
						1		
						TOTAL (HRS)		
						24		
						285.25		

28.75

Cultus Petroleum DAILY DRILLING REPORT

WELL: BALEEN #2
 PERMIT: VIC/RL5
 RIG: SEDCO 702

DATE: 18.10.99
 REPORT # 9
 D.F.S. 8

FROM	TO	HOURS	
0:00	0:30	½	Logging run # 6. Schlumberger MDT tool.
0:30	1:15	¾	L/d MDT string.
1:15	2:30	1¼	Evaluate options.
2:30	2:45	¼	R/d Schlumberger.
2:45	4:45	2	Hold JHA. P/u 20 jts 2-7/8" tubing as cementing stinger.
4:45	6:15	1½	RIH w/ cement stinger to 890m.
6:15	6:45	¾	Circulate bottoms up. Hold cementing JHA.
6:45	7:15	¾	Pressure test cement line 2000 psi. Pump plug #1 890m to 790m. 128sx neat "G" at 15.8 ppg.
7:15	8:00	¾	POOH to 760m.
8:00	8:30	½	Circulate bottoms up.
8:30	9:30	1	Set balanced plug #2 f/ 760m to 600m. 217sx "G" neat at 15.8 ppg.
9:30	10:30	1	POOH to 550m.
10:30	10:45	¼	Circulate bottoms up.
10:45	11:15	½	Function Annular BOPs.
11:15	12:00	¾	POOH w/ drill pipe.
12:00	13:45	1¾	Hold JHA. L/d 2-7/8" tbg.
13:45	16:00	2¼	RIH w/ 6½" drill collars. Hold JHA. L/d drill collars.
16:00	17:45	1¾	M/u mule shoe on 5" drill pipe. RIH and tag cement at 580m.
17:45	18:00	¼	Circulate hole w/ inhibited mud.
18:00	18:45	¾	POOH w/ drill pipe.
18:45	19:00	¼	R/u Schlumberger.
19:00	19:15	¼	M/u Gauge ring and junk basket.
19:15	20:00	¾	RIH w/ 8.5" Gauge ring and junk basket to 190m.
20:00	20:15	¼	L/d gauge ring and junk basket.
20:15	20:30	¼	Raise radio silence permit. P/u 8.5" EZSV bridge plug.
20:30	21:00	¾	RIH w/ EZSV and set at 180m.
21:00	21:30	¾	POOH. R/d Schlumberger.
21:30	22:00	¾	RIH w/ 5" drill pipe. Tag EZSV at 180m. P/u to 175m.
22:00	22:30	¾	Circulate hole to seawater. Flush choke & kill lines. Hold cementing JHA.
22:30	23:00	¾	Pressure test cement line 2000 psi. Pump plug #3 f/ 175m to 125m. 50sx neat "G" at 15.8 ppg.
23:00	23:30	¾	R/d cement line. POOH to 120m.
23:30	23:45	¼	Space cut in stack. Close annular and reverse circulate until clean.
23:45	23:59	¼	POOH 1std and circulate out.

OPERATIONS TO 0600 HRS: Pull flex jt bore protector and wear bushing. M/u jetting stand. Pull diverter and pin slip jt. Unlatch BOP.

PROGRAMME NEXT 24 HRS: Pull stack and retrieve wellhead. Pull anchors.

BULK	GEL(sx)	BARITE(sx)	CEMENT(sx)	DRILLWATER(mt)	POT WATER(mt)	DIESEL FUEL(lt)	HELI FUEL(lt)
	612	1893	964	912	210	234.6	0
PERSONNEL ON RIG		TRANSPORTATION			COSTS		
OPERATOR	3		NAME	LOCATION	DAILY MUD	\$9,281	
DRILLING CONT.	61	WORKBOAT	Challenger	Rig	CUMULATIVE MUD	\$58,626	
SERVICE COMPS	17	WORKBOAT	Shogun	Rig	DAILY WELL	\$215,400	
OTHER		STANDBY BOAT			CUMULATIVE WELL	\$3,144,120	
		HELICOPTER	1		ACCIDENTS / INCIDENTS	NIL	
TOTAL	81	HELICOPTER			DAYS SINCE LTA	677	
SUPERVISOR(S)	Kohut / Westman		ENGINEER	Boon	OIM	Dibon	

Cultus Petroleum DAILY DRILLING REPORT

WELL:	BALEEN #2	DATE:	19-Oct-99
PERMIT:	VIC/RL5	REPORT #	10
RIG:	SEDCO 702	D.F.S.	9

DEPTH 2400 Hrs:	PBSD 125m	STATUS @ 2400 Hrs:	complete pulling anchors and release rig at 23:30 hrs	
TVD:	0	FORMATION:		
24 HR PROGRESS:	0	LAST CASING:	9-5/8" @ 646m	SHOE L.O.T.:
HOLE SIZE:		WD (MSL):	55	RT - SEABED/MSL: 81
SURVEYS:		MAASP:		

MUD PROPERTIES		ADDITIVES	SOLIDS CONTROL			FORMATION DATA			
DENSITY(ppg)				pm	uf	hrs	DEPTH		
VISCOSITY(Sees)		DESILTER					Total Gas (%)		
pH		DESANDER					C1 ppm		
PVYP(cp/lb/100ft2)		MUD CLEANER					C2 ppm		
GELS 10/10		CENTRIFUGE					PORE PRESS (SG)		
WL AP(cc/30min)			1	2	3		ECD (ppg)		
WL HTHP(cc/30min)		SHAKERS	Thule	Thule	Thule		LITHOLOGY		
CAKE(mm)		SCREENS	52/120	52/120	52/120	DRILLS / BOPS			
SOLIDS %		PUMPS	1	2	3	LAST BOP DRILL		16.10.99	
SAND %		TYPE	A1700PT	A1700PT	A1700PT	LAST FIRE DRILL			
CHLORIDES(mg/l)		STROKE(in)	12	12	12	LAST MOB DRILL			
NaCl %		LINER(in)	6"	6"	6"	LAST ABN. RIG DRILL		10.10.99	
MBT(lb/bbl)		SPM				LAST BOP TEST		9.10.99	
TEMP °C		GPM				BOP TEST DUE		23.10.99	
HOLE VOL(bbl)		AV-DP(ft/min)					HRS	CUM	
Total Vo(bbl)		AV-DC(ft/min)				1. MOVE RIG		81.5	
NITRATE ppm		SPP(psi)				2. RUN ANCHORS	7	21	
MUD Co		SCR @ 30				3. DRILLING		39.5	
MUD TYPE		SCR @ 50				4. TRIP	3	61.5	
BIT DATA		WEATHER / RIG RESPONSE							
BIT No.		WIND SPEED(kts)		15	5. WIPER TRIP				0
SIZE(mm/in)		DIRECTION(°)		240	6. SURVEY				0.5
TYPE		TEMPERATURE(°C)		13-15	7. CIRC./COND				8
IADC CODE		BAR. PRESSURE(kPa)		1013	8. HANDLE BHA				1.5
SERIAL No.		BAR. RISE / FALL(kPa)		-2	9. CASE/CEMENT				15.5
NOZZLES(32in)		VISIBILITY(NM)		12	10. WELLHEAD				
DEPTH IN (m)		WEATHER STATE		Cbudy	11. BOPS				8.75 25
DEPTH OUT (m)		SWELL / PER / DIR(m/sec*)		5/2/205	12. LOT				0.5
DRILLED (cum/dly)		WAVES / PER / DIR(m/sec*)		1.2/4/20	13. CORING				2
HOURS (cum/dly)		HEAVE(m)			14. LOGGING				36.5
GRADE		PITCH(°)		2 x 7	15. REAMWASH				6.75
AVGE ROP (m/hr)		ROLL(°)		4 x 7	16. FISH/STUCK				
WOB (mt)		ANCHOR TENSION-MIN(MT)		0	17. LOSS CIRC				
RPM		ANCHOR TENSION-MAX(MT)		0	18. KICK CONTROL				
JET VEL (ft/sec)		RISER TENSION(MT)		0	19. SIDETRACK				
HHP @ BIT		VARIABLE DECK LOAD(MT)		1958	20. JHA				
BHA No.		BHA WEIGHT		STRING WT	21. REP SURF				
BHA Profile :					22. WELL TEST				
					23. WO WEATHER				
					24. Function test				0.75
DOWNHOLE TOOLS	SERIAL No.	ROT/REAM HRS	DRILLING DATA		25. ABANDON				4.75 6.75
			DRAG - UP (mt)		26. RIG SERVICE				0.5
			DRAG - DOWN (mt)		27. SLIP/CUT LINE				
			TORQUE-On Bottom (amps)		28. PULL ANCHORS				
			TORQUE-Off Bottom (amps)		29. DRILLS				1
					TOTAL (HRS)				23.5 308.75

28.75

903058 340

903058 341

6.0 SAFETY AND INCIDENTS

There were no lost time incidents on the Baleen-2 well. Once incident occurred and its follow-up is enclosed.



REC

26

903058 343

Swire Pacific Offshore Pty Ltd
2nd Floor Queensgate centre, Cnr William and Newman Streets, Fremantle WA
Ph: 08 94305434 Fx: 08 94307849 Email: idelrosso@spofftv.com
ACN: 003 428 78

To: Ray Kohut, Cultus Fax: 02 94181756

From: Ian Del Rosso Date: 26/11/99

Re: Close out report Pacific Challenger Pages: 3
incident, Baleen #2

CC:

Urgent For Review Please Comment Please Reply

Ray,

Please find attached, close out report for the above mentioned incident, please advise should you require any further information:

I can confirm that all items mentioned have been closed out on board, which include revising the existing JSA, use of the suitcase hook, and safety alert distributed

Hazard reports will be forwarded to Sedco for comment.

Should you have any further queries please do not hesitate to contact em at any time.

Thanks and regards

Ian Del Rosso

Swire Pacific Offshore Pty Ltd

Operations/Safety Manager



903058 344

Close out report, Near Miss Incident, Ken Blackband Pacific Challenger.

Background:

The incident occurred when the Pacific Challenger was passing back the tow bridle to the Sedco 702 at the Baleen #2 location.

The problems associated with connecting the bridle leg at this draft had been discussed with Capt Pat Cotton on 20/9/99 around the move from Turrum to Barramundi locations. On this occasion only one casing sling was connected and in the poor weather it was difficult to connect.

Capt Cotton advised both vessels that he had ordered 24mm wire in order to put the correct length of pickup wire on the bridle, but this had not happened by the time the vessels were on the Baleen well.

An extra casing sling had been added to increase the length of the pickup but both vessels had expressed dissatisfaction at this arrangement, as the vessels could not see when the weight was coming onto the wire.

The 24 mm wire has still not been supplied or fitted to the Sedco 702 tow bridle so the method used to deploy the bridle, ie small messenger rope and a cargo sling is still in use.

Clarification on issues raised from the Cultus report:

With reference to the methods used to on both vessels, as each vessel is different, with different deck length and widths, with tuggers on one vessel at deck level whilst the Challenger is at the next deck up, the way the deck is rigged cannot be the same.

Both vessels have the same equipment on board, and the Pacific Challenger is equipped with the same hook as the Shogun, but did not use it.

Vessels have been working the Sedco 702 for a considerable period of time with no incident prior to this one, JSA's are used and per rigshift toolbox meetings are used prior to each rigshift.

As can be expected each Master has their own method of operation, due to differences in the vessels back deck configuration, rigging of the deck may not be the same. The Pacific Challenger made the decision to employ the sacrificial rope method for disconnecting the bridle; a suitcase hook was available but was not used.

Conclusions and actions taken:

- 1: Pacific Challenger to review method of operation to incorporate the suitcase hook.
- 2: JSA to be reviewed/re written to ensure suitcase hook and hazards are noted.
Sacrificial rope not to be used
- 3: Ensure crews are not in the bight of the tugger wire, thus ensuring personnel are not in danger. Which could have been done if the tugger had been lowered to the tow pins, and disconnection of the port tugger had been done at this point.



908058 345

Conclusions and actions taken (continued):

4: The Chief Officer involved should not have been in this position, should basic rules have been followed this incident could have been averted.

5: Persons on deck to ASSUME weight are applied to wires at all times and take necessary precautions.

6: Fleet alert to this effect to be distributed as the safety theme for the quarter.

Action to be taken by the vessel and management: Due: Immediate.**Actions by Sedco 702**

Sedco 702 to provide an appropriate sized messenger, for this operation, numerous discussions and hazard reports have been made from the support vessels and the rig management with no result.

All crew are experienced at Anchor handling operations, both Masters at the time are very experienced having served as Master on Swire Pacific Offshore for 10 years.

Other considerations:

Another consideration was the operation of the bridle retrieval tugger on the rig, it has been reported that this was being operated at the time the rope messenger broke, whether this is a contributing factor to the sudden weight coming onto the rope, is unclear, but worth considering.

The inexperience of the Chief Officer could have been a factor. Whilst he has been with the company for 12 months and has served on deep-water vessels, his inexperience in anchor handling operations caused an error in judgement. It is basic seamanship not to stand in the bight of a rope and complacency, in the fact that it was assumed the rope had no weight on it caused the error. We feel that this error in judgement was a major contributing factor in this incident.

Both Masters have made the statement that rather than finding a safer method of performing a hazardous operation it is surely better to eliminate the hazard in the first place. Providing the correct wires rather than casing slings could have eliminated the hazard, needless to say that the vessel must reduce the risk to as low as practicable, which is done using safety systems in place on board and using equipment available.

CW

Schlumberger

Sedco Forex

SEDCO 702

14th October 1999**908058 346**

To : Ray Kohut
Cultus Drilling Supervisor
From : J.J.Dibon
S702 MIC
Date : 14th October 1999

Subject : Comments on Pacific Challenger Incident 10th October 1999

Ray,

My comments on the Pacific Challenger's incident are as follow:

- 1 - This incident should have been reported immediately to the rig, instead of being reported to town and back to us 4 days later.
- 2 - There is some concerns about the length of the 702 tow bridle sling, why this issue was not addressed before the incident?
A pre- Move meeting was held with both of the boat Captains on the rig and no oncerns have been raised regarding the slings on the tow bridle.
I have discussed the subject with the Captain and Marine crew and found out that in the past we were using one 20 feet sling. On Boat Captains request the quantity was increase to three, but this was too long and the decision to use two of these 20 feet slings was agreed by all parties. Since then no complaints have been made.
The tow bridle had the same configuration for the tow from Turrum to Barramundi and from Barramundi to Baleen.
- 3 - According to the marine crew on board the 702, the Pacific Shogun is using a "suitcase hook" for the bridle disconnection and it seems to be a much more safer and professional way to carry on this operation than the use of a rope. The Captains should discuss the procedure and riggings together.

Regards,

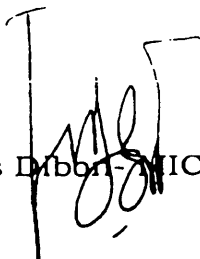

Jean-Jacques Dibon - MIC Sedco 702



903058 347

Swire Pacific Offshore Pty Ltd
2nd Floor Queensgate centre, Cnr William and Newman Streets, Fremantle WA
Ph: 08 94305434 Fx: 08 94307849 Email: idelrosso@spopty.com
ACN: 003 428 78

To: Chris Way, Offshore Operations Manager, Cultus Fax: 02 94181504

From: Ian Del Rosso Date: 13/10/99

Re: Near Miss Report Pages: 4

- Urgent For Review Please Comment Please Reply

Chris,

Please find attached a copy of an injury/near miss report, relating to an incident which occurred on the Pacific Challenger Sunday 10/10/99.

We have only rcvd this report via mail this afternoon; we were not informed of this incident at all by the vessels Master.

Company policy is for the Master to report any incident, especially serious ones to the GM Sam Pullan or in his absence, either myself or Dave Marren ASAP.

Both vessels are well aware of this requirement and also have all after hours contact details, All management have after hours fax numbers so contact is not an issue.

This incident will be investigated further, and I will keep you informed as information comes to hand.

Primarily the Chief officer involved has not suffered any injury; he attended the local Doctor as a precaution and is still fit for duty.

Please do not hesitate to contact me at any time should you need further information or clarification on the attached report.

Regards 

Ian Del Rosso

Operations/Safety Manager

Swire Pacific Offshore Pty Ltd



13 OCT 1999

INCIDENT REPORT - PAGE 1

DAMAGE

Reference No. (For Office Use Only)

NEAR MISS

A SEPARATE FORM SHOULD BE COMPLETED FOR EACH PERSON INJURED

908058 343

1. SHIP

IMO SHIP IDENTIFICATION NO. 8209274 DATE 10/10/99
Name: Pacific Challenger 1 Output Code AUS
Type: Tug [] AHTS [x] DSV [] Maintenance [] Survey [] Other []

2. TIME AND DATE OF INCIDENT

TIME AND DATE REPORT RECEIVED

1300 24 Hour Clock Format 10/10/99

1300 24 Hour Clock Format 10/10/99

MTWTFSS (S)

By Whom Reported: K. Blackburn

Type of Incident Code B Place of Incident Code C

To Whom Reported: MASTER

3. INCIDENT RESULTS

Fatal [] Lost Time [] Restricted Work [] Medical Treatment [] First Aid [x] Property Damage [] Near Miss []

NATURE OF INJURY OR DAMAGE

LOCATION OF INJURY OR DAMAGE

BRUISING + CONTUSIONS

BOTH SHINS - FRONT

Lost Time Incident: Yes [] No [x] (subject to Management Review)
Anticipated Period (days) of Incapacity <1 [] <3 [] <7 [] <30 [] <90 [] >90 [] Severely Disabled [] Fatality []

4. SEAFARER (Complete only if person injured)

KENNETH BLACKBAND Surname First Name D. Other In's
Lot 6 Logwoods Road Street No. and Name EUDLO Town / City QLD 4554 Country
Date of Birth 11/04/73 Gender M M/F Nationality AUSTRALIAN Discharge Book No.
Port of Engagement: BRISBANE Date of Engagement 02/06/99 Rank / Rating Code D03

5. INCIDENT DETAILS

If at Sea, State Lat: 38° 01' S Long: 148° 25' E If in Port, State Name:
Weather: Good [x] Moderate [] Bad [] Shipping Seas/Spray [] Ice/Snow on Deck []
Was Seafarer at authorised place of work: Yes [x] No [] Was Seafarer Sober: Yes [x] No []
Was Seafarer on Duty: Yes [x] No [] If on duty, hours worked continuously prior to Incident: 4
Total number of hours worked by Seafarer in the 24 hours prior to the Incident: 12
What was the source of lighting? NATURAL
Name and address of witnesses: G. Richter 1/2 - 30, Loudon St. Sandgate QLD 4017

6. INJURY

Nature of Injury / Occupational Illness Code E02 Body location of Injury F54 Mechanism of Injury G12
Date Injured Seafarer Ceased Work: N/A Was a log entry made? Yes [x] No []
If Yes, Copies of all relevant Log Entries must accompany this Report.
Was Seafarer Discharged through Injury: Yes [] No [x]
If Yes, State Name of Port and Date:

7. If Accident Due to Breakage of Gear, Broken Parts must be carefully preserved

Signed [Signature] Print Name P.J. Ritter Rank MASTER

Reference No.
 (For Office Use Only)

NOTE: This investigation is aimed at identifying causes, not attributing blame.

1. SHIP

IMO SHIP IDENTIFICATION NO. **8209274** DATE **10 10 99**
 Name: **PACIFIC CHALLENGER 1** Outport Code **AUS**

8. DESCRIPTION OF INCIDENT (Include any particular chemical, product, process, equipment involved)

What General Activity was being done at the time? **H 0 2**

RELEASING TOW BRIDLE LEG TO S600 702

How exactly was the injury or damage sustained? Specific Activity Undertaken **J 2 2**

THE TOWLINE HAD BEEN DISCONNECTED, 2 TUGGERS RIGGED TO TOW BRIDLE, WEIGHT TAUGH ON BOTH TO LOWER JAWS + PASS BACK TO RIG. PORT TUGGER WENT DIRECT TO SLINGS ON BRIDLE, STBD TUGGER VIA ROPE

What happened unexpectedly? (Undesired event) **SLINGS TO BRIDLE**

ROPE JOINING STBD TUGGER TO CASING SLINGS ON TOW BRIDLE PARTED THIS CAUSED ALL WEIGHT TO COME ON PORT TUGGER + KNOCK MAN OFF FEET.

Reconstruct the sequence of events that led to the undesired event

- 1 SLINGS ON TOW BRIDLE TOO SHORT
- 2 TO FACILITATE SAFE DISCONNECTION
- 3 WHILST RIG AT 80' DRAFT.
- 4 STBD TUGGER FITTED WITH ROPE TO CUT
- 5 BOTH TUGGERS SUCKED - MATE TO RELEASE
- 6 ROPE ON STBD PARTED DUE TO EXCESS WT.

9. INCIDENT CAUSES

Immediate Causal Factors **K 2 1**

DIVE TO S600 702 TOWING AT 80' DRAFT - TO CONNECT + RELEASE THE TOW BRIDLE THE VESSEL HAS TO MANOEUVRE VERY CLOSE TO RIG + PICK UP BRIDLE WITH HEAVING LINE + 2-CASING SLINGS

Underlying Causal Factors **L 2 2**

RIG SHOULD HAVE LONGER PICK UP WIRE TO BRIDLE LEG WHEN WORKING AT THIS DRAFT TO PREVENT THIS HAZARD. THEN TUGGERS COULD BE WORKED ON/RELEASED WITH SUCK

10. CORRECTIVE / PREVENTIVE ACTION

PROPOSED	Responsibility	Completion Dates		TAKEN
		PROPOSED	ACTUAL	
BOTH TUGGERS SHOULD HAVE BEEN LOWERED TO PINS BEFORE TRYING TO DISCONNECT PORT ONE	MASTER	11/10	11/10	REVISE PROCEDURE TO RELEASE ISSUE HAZARD REPORT INFORM 702 TO GET LONGER PICK UP WIRDS FOR THIS JOB

INVESTIGATING OFFICER **P.J. RUTGER** **MASTER** **11 10 99**

11. MANAGER'S COMMENTS (Manager to Sign and Date)

Change to work environment	Equipment / machinery maintenanc	Proposed	Taken	Other job redesign	Other preventive action	Proposed	Taken
		<input type="checkbox"/>	<input type="checkbox"/>			<input type="checkbox"/>	<input type="checkbox"/>
13/10/99		GENERAL FAXED TO ALL BOATS					
Signature		Day		Month		Year	

12. SAFETY MANAGER'S COMMENTS

Signature Day Month Year

903058 350



Reference No.
(For Office Use Only)

INCIDENT REPORT - PAGE 3
FURTHER INFORMATION / DIAGRAMS

903058 351

1. SHIP
 IMO SHIP IDENTIFICATION NO. 8209274 DATE 10 10 99
 Name: PACIFIC CHALLENGER 2 Output Code AUS Day Month Year
 CHARTERER CULTUS

13.

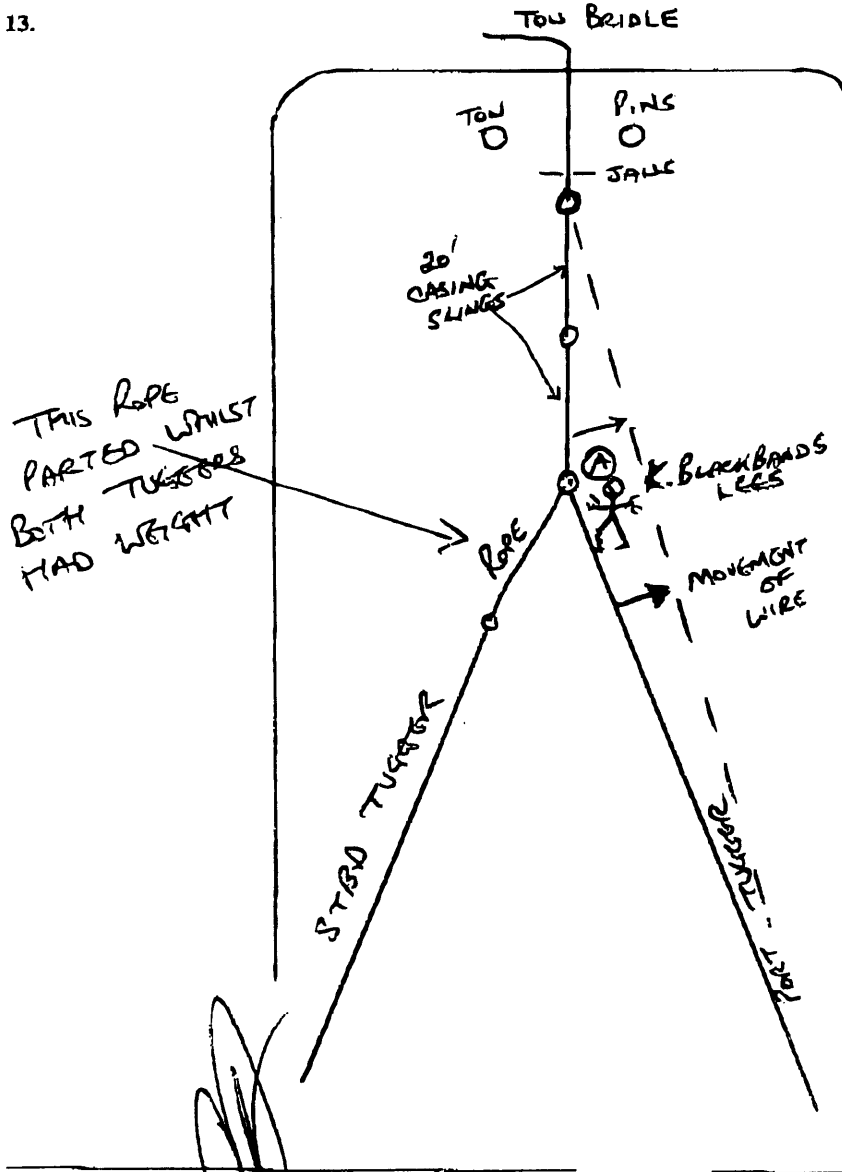

(A)
 K. BLACKBANDS WAS IN THIS POSN TO RELEASE THE PORT TUGGER.

Signature of Master / Chief Off. / C.E.O.

Signature of Witness & Rank

Classification Society Survey	Yes	No
Underwriter's Survey		
Owner's Survey		
Log Extract Attached		

The above statements are true and correct.
 Responsibility is hereby admitted.

Signature of Master of Colliding Vessel or Party Concerned