

W891.

WCR VOL 1

EAST KWGFISH-1

W 891

**OIL and GAS DIVISION**  
**WELL COMPLETION REPORT**

**EAST KINGFISH-1**

**VOLUME 1**  
- 2 MAY 1985

**GIPPSLAND BASIN**  
**VICTORIA**

**ESSO AUSTRALIA LIMITED**

**Compiled by: S. WATTS**  
**P. FELL**

**March, 1985**

EAST KINGFISH-1  
WELL COMPLETION REPORT  
VOLUME 1  
BASIC DATA

CONTENTS

1. WELL DATA RECORD
2. OPERATIONS SUMMARY
3. CASING DATA
4. CEMENT DATA
5. SAMPLES, CONVENTIONAL CORES, SIDEWALL CORES
6. WIRELINE LOGS AND SURVEYS
7. RFT SURVEY AND RESULTS
8. TEMPERATURE RECORD

FIGURES

1. LOCALITY MAP
2. WELL PROGRESS CURVE
3. WELL BORE SCHEMATIC
4. ABANDONMENT SCHEMATIC
5. HORNER TEMPERATURE PLOT - LOGGING SUITE 1

APPENDICES

1. LITHOLOGICAL DESCRIPTIONS
2. CONVENTIONAL CORE RECORD
3. SIDEWALL CORE DESCRIPTIONS
4. SIDEWALL CORE GAS ANALYSIS

(2258f15)

ESSO AUSTRALIA LTD

COMPLETION REPORT

1.

WELL : East Kingfish 1

LOCATION : Latitude : 38° 35' 07.37"S  
Longitude : 148° 12' 36.73"E  
X = 605,404mE  
Y = 5,728,523mN  
Map Projection: AMG Zone 55  
Geographical Location: Bass Strait  
Field: Kingfish

PERMIT : VIC/L7

ELEVATION : 21m KB

WATER DEPTH : 77m

TOTAL DEPTH : 2421m TVD  
: 2638m MD (NB. Well is deviated)

PLUG BACK TYPE : Balanced Cement Plug

REASONS FOR PLUGGING BACK : Plug and Abandonment

MOVE IN : 29th November, 1984

SPUDDED : 30th November, 1984

REACHED T.D. : 23rd December, 1984

RIG RELEASED : 4th January, 1984

OPERATOR : Esso Exploration and Production Australia Ltd

PERMITTEE OR LICENCEE : Esso Exploration and Production Australia Ltd  
and B.H.P. Petroleum Pty Ltd

ESSO INTEREST : 50

OTHER INTEREST : 50

CONTRACTOR : South Seas Drilling Company

RIG NAME : Southern Cross

EQUIPMENT TYPE : Semi-Submersible

TOTAL RIG DAYS : 37

DRILLING AFE NO. : 05-308-534-300

TYPE COMPLETION : Plug and Abandonment

WELL CLASSIFICATION : Before Drilling Extension/Development Test  
After Drilling Successful Delineation Well

24141/17

ESSO AUSTRALIA LTD  
EAST KINGFISH-1  
SEQUENTIAL OPERATIONS

2.

Mooring

The Southern Cross departed Grunter-1 location at 1730 hours November 28, 1984 and arrived at the East Kingfish-1 location at 0415 hours November 29, 1984. The 27 nautical mile tow was completed in 10-3/4 hours at an average speed of 2.51 knots using the Lady Sally as the tow boat.

Anchor No. 8 was dropped by the rig and the remaining anchors were run by the workboats Lady Sally and Swan Tide. Due to the close proximity to the Kingfish oil pipeline, the Flinders Tide monitored the setting of anchors 1,2,3 and 4. An RCV was used to ensure that none of these anchors were within the restricted zone of 200m surrounding the pipeline.

The pendant wire for anchor 2 parted while the anchor was being run and the anchor was dropped 70m from the required position. Bad weather precluded stripping over and recovering the anchor so a 150m section of chain was removed to enable placement of wire through the fairleader.

All anchors were pretension to 200 kips.

Final rig location was: Latitude 38° 35' 07.37" S  
Longitude 148° 12' 36.73" E  
X = 605,404m E  
Y = 5,728,523m N

AMG Zone 55, Universal Transverse Mercator Projection, Australian Geodetic Datum.

The rig was located 5.64m at 052° from the called location and approximately 80kms at 180° from Lakes Entrance.

Drill 26" hole for 20" conductor

The drilling template was run and landed at a seafloor depth of 98m RKB. The 26" hole was drilled to 236m using seawater and high viscosity gel slugs to clean the hole. At TD the hole was displaced with high viscosity mud and a wiper trip was made to the seafloor.

The 18-3/4" wellhead and 20" casing were run and cemented with the casing shoe at 221m RKB. The BOP stack and riser were run and the casing and collet connector tested against the shear rams to 500 psi.

Drill 17-1/2" hole fro 13-3/8" casing

After drilling out the cement and casing shoe, the 17-1/2" hole was drilled to 828m using seawater and high viscosity gel slugs. A wiper trip was made to the 20" shoe and the hole conditioned to run casing.

While pulling out, the 17-1/2" bit was run into the diverter bag with the dogs still locked in place. This caused the latch pin on the elevators to shear off and released the bottom hole assembly (BHA) which fell back to bottom. The BHA was successfully fished with an overshot.

After making a second conditioning trip, 13-3/8" casing was run and cemented with the casing shoe at 813m. The plug was bumped with 1500 psi. The 13-3/8" Cameron Lo-Torque seal assembly was run, set and tested to 200/5000 psi. The BOP rams and C&K valves were tested to 200/5000 psi and annular preventers were tested to 200/3500 psi.

#### Drill 12-1/4" hole

Repairs were carried out to the diverter and after drilling out the cement and float equipment, new hole was drilled to 834m and a Phase II PIT was conducted to 19.5 ppg EMW without leak off. Drilling was continued to the kick off point at 850m, where a survey was taken.

The well was kicked off using a 9-5/8" Dyna drill, a 1-1/2° bent sub, and a Teleco MWD tool. The kick off assembly drilled to 1061mMD with an azimuth of 135° and inclination of 14.25°. An angle building assembly built the angle to 29.75° at 1215mMD. However, carryover from the kickoff hole section pushed the well on a heading of 127.5°. Since this heading aimed the well to outside of the left target boundary, a correction assembly, consisting of a Dyna drill, 2° bent sub, and Teleco MWD tool, was used to correct the heading and increase the inclination. The assembly was tripped to replace a faulty Dyna drill and Teleco tool at 1278mMD. The correction run was terminated at 1310mMD with an azimuth of 144° and inclination of 32.5°. A hold angle BHA drilled to 1543mMD but the hole angle dropped to 28.75°. The belly between the tandem near bit stabilizers and string stabilizers was increased by replacing two 8" DC pups with the 7-3/4" Teleco tool. The hole was drilled to 1610mMD and a survey of 1598mMD showed the hole angle to have dropped back to 26°.

While changing out the BHA, a longitudinal crack was found in the box end of an 8" drill collar. A small wash had also developed in the pin of the mated drill collar. Both collars were laid down.

The belly in the BHA was increased with the movement of a 8" non-magnetic drill collar between the Teleco tool and the tandem string stabilizers. The hole was drilled to 1739mMD where the angle was surveyed at 1722mMD to be 30.25° with a heading of 156°. A hold angle BHA was made up and the Teleco tool was placed above the tandem string stabilizers.

Since the well heading had increased from 146° at 1560mMD to 156° at 1722mMD and the well path appeared that it would miss the target boundary, a 200m extension was granted to the right of the target boundary.

Drilling resumed to 1883mMD where a 400 psi pressure drop and a 4SPM increase indicated a possible washout. After checking the surface equipment for leaks, the string was pulled wet and a vertical crack was found in the box of an 8" drill collar. All 8" drill collars were replaced with new 8" drill collars. Drilling continued to the top of Latrobe at 2496mMD. After circulating bottoms up, a wiper trip was made prior to cutting core #1.

Two plastic liner and two sponge liner cores were cut over the interval 2496 - 2530m MD.

After reaming out the core rathole, the 12-1/4" hole was drilled to TD at 2638mMD. A multi-shot survey was taken from TD to the 13-3/8" casing shoe. The survey showed the well path to be just outside the right target boundary.

Four electric logs, one RFT and one CST were run at TD. Due to poor reservoir quality, 9-5/8" casing was not set and the well was abandoned.

#### Plug and Abandonment

A 525 sack cement plug was set from 2570 to 2435m. After waiting on cement, the plug was tagged at 2418m with 15 kips. A second 290 sack cement plug was then set from 865m to 765m. The plug was pressure tested to 1500 psi.

After making a gauge ring/junk basket run to 740m, a 13-3/8" EZSV bridge plug was run and set at 715m. The 13-3/8" casing was cut with a Pengo cutter at 196m and an injection rate of 8 BPM at 500 psi was established into the annulus. The seal assembly was retrieved with its running tool. A 500 sack cement plug was set across the stub from 220m-134m with 18 bbls being squeezed into the 20" x 13-3/8" annulus. The plug was tested to 500 psi.

After waiting on weather for approximately 3 days the BOP stack and riser were pulled. A 3.7kg shaped explosive casing cutter was run below the wellhead running tool, made up in the wellhead and cut the 20" casing at 109m. The drilling template, 4 post guide base and pile joint were recovered.

#### Pulling Anchors

Six moorings were stripped over because the buoys broke loose during the well. Approximately 4.5 days were spent waiting on weather, waiting on workboats to strip over the moorings, and stripping over the moorings prior to departing the East Kingfish-1 location.

The Southern Cross was taken under tow by the Atlas Dampier at 2115 hours January 4, 1985 enroute to the Bream Soil Boring location.

24141/22-24





4.

## CEMENT DATA

WELL EAST KINGFISH-1

DATE	DEPTH METRES	TYPE JOB	TYPE CEMENT	AMOUNT	ADDITIVES	REMARKS
Dec 1	221.07	Primary 20" Casing	Class "G"	750 SX	2.2% Gel	Lead Slurry Avg Slurry Wt 13.3 ppg
		Primary 20" Casing	Class "G"	350 SX	Neat w/seawater	Tail Slurry Avg Slurry Wt 15.8 ppg
Dec 4	813.00	Primary 13-3/8" casing	Class "G"	1050 SX	Neat w/seawater	Avg Slurry Wt 15.8 ppg Plug bumped w/1500 psi
Dec 25	2570- 2418	P&A Plug #1	Class "G"	525 SX	0.8% HR6L w/fresh- water	Avg Slurry Wt 16.0 ppg Tagged w/15 kips
Dec 26	865- 765	P&A Plug #2	Class "G"	290 SX	Neat w/seawater	Avg Slurry Wt 15.8 ppg Tested to 1500 psi
Dec 26	715	13-3/8" Bridge Plug				
Dec 26	220- 134	P&A Plug #3	Class "G"	500 SX	Neat w/seawater	Avg Slurry Wt 15.8ppg Squeeze 18 bbls into 13- 3/8"x20" annulus Tested to 500 psi

WELL: EAST KINGFISH-1

5. SAMPLES, CONVENTIONAL CORES, SIDEWALL CORES

<u>INTERVAL</u>	<u>TYPE</u>
221.00-2638.00m	4 sets of washed and oven dried and 2 sets of lightly washed, airdried and bagged samples every 5 metres, except during cored intervals.
221.00-2638.00m	1 set of unwashed canned cuttings every 15 metres.
2390.00-2638.00m	1 set of canned fission track samples every 30 metres.
2617.55-2440.01m	Sidewall Cores (Shot 30, recovered 22)
2496.00-2502.00m	Sponge Core No.1 (Recovered 3.83m)
2502.00-2512.00m	P.V.C. Liner Core No. 2 (Recovered 9.1m)
2512.00-2521.40m	Sponge Core No. 3 (Recovered 0.62m)
2521.40-2530.40m	P.V.C. Liner Core No. 4 (Recovered 9.0m)

24141/19

WELL: East Kingfish 1

6.

WIRELINE LOGS AND SURVEYS

<u>Type and Scale</u>		<u>From</u>	<u>To</u>
			<u>Suite 1</u>
BHC GR	1:500 1:200	2626.5	814m
DLTE MSFL GR	1:500 1:200	2630	815m
LDTC CNTH GR	1:500 1:200	2618	2400m
DITD GR	1:500 1:200	2633.5	2450m
HDT GR	1:200	2635	2430m
CST GR	1:200	Run 1	
RFT GR Pressure Record	1:200	Run 1	
RFT HP Pressure Record	1:200	Run 1	
AMS Log	1:200	2618	2400m
EPT GR	1:200	2634	2450m

24141/18

7.

## SUMMARY OF WIRELINE FORMATION TEST PROGRAMME - EAST KINGFISH I

TEST	SEAT	DEPTH (METRES) K.B.	CHAMBER	RECOVERY (LITRES)				HEWLETT-PACKARD FORMATION PRESSURE		HEWLETT-PACKARD HYDROSTATIC PRESSURE		REMARKS	
				OIL	COND.	GAS	FORMATION WATER	MUD FILTRATE	MPaa	Psia	MPaa		Psia
			Litres	Litres	Litres	m <sup>3</sup>	Litres	Litres					
1	1	2565	Pretest						22.7	3292.02	25.6	3716.70	Valid
	2	2537	Pretest						22.5	3258.58	25.4	3679.50	Valid
	3	2531.5	Pretest						22.4	3251.77	25.3	3673.41	Valid
	4	2526	Pretest						22.4	3245.92	25.3	3665.73	Valid
	5	2520.5	Pretest						22.3	3239.18	25.2	3657.83	Valid
	6	2514.5	Pretest						22.3	3232.32	25.2	3649.63	Valid
	7	2509	Pretest						22.3	3240.14	25.1	3642.32	Super charged
	8	2500	Pretest						22.2	3219.95	25.0	3630.97	Super charged
	9	2505	Pretest						22.3	3229.30	25.1	3638.65	Super charged
	10	2507.8	Pretest								25.1	3645.12	Invalid, tight
	11	2507.8	Pretest						22.2	3225.5	25.1	3642.51	Valid
	12	2498.8	Pretest						22.2	3218.37	25.0	3627.26	Valid

24141/28

8.

TEMPERATURE RECORD - EAST KINGFISH 1

LOGGING RUN	THERMOMETER DEPTH (m)	MAX. RECORDED TEMPERATURE (C°)	CIRCULATION TIME ( $t_k$ ) (hours)	TIME AFTER CIRCULATION STOPPED (t)	HORNER TEMPERATURE (C°)	GEOHERMAL GRADIENT (C°/km)
<u>Suite 1</u>						
BHC GR	2626.5	82.00	1.25	13.50	93.80	36.10
DLTE MSFL GR	2630.0	73.00	1.25	7.25		
LDTC CNTH GR	2618.0	73.00	1.25	7.25		
DITD GR	2633.5	82.00	1.25	13.50		
HDT	2635.0	101.00	1.25	22.52		
AMS Log	2618.0	73.00	1.25	7.25		
EPT-GR	2634.0	88.00	1.25	20.45		
RFT (RUN 1)	2565.0	86.00	1.25	29.10		

24141/27

FIGURES

148°05'

148°10'

148°15'

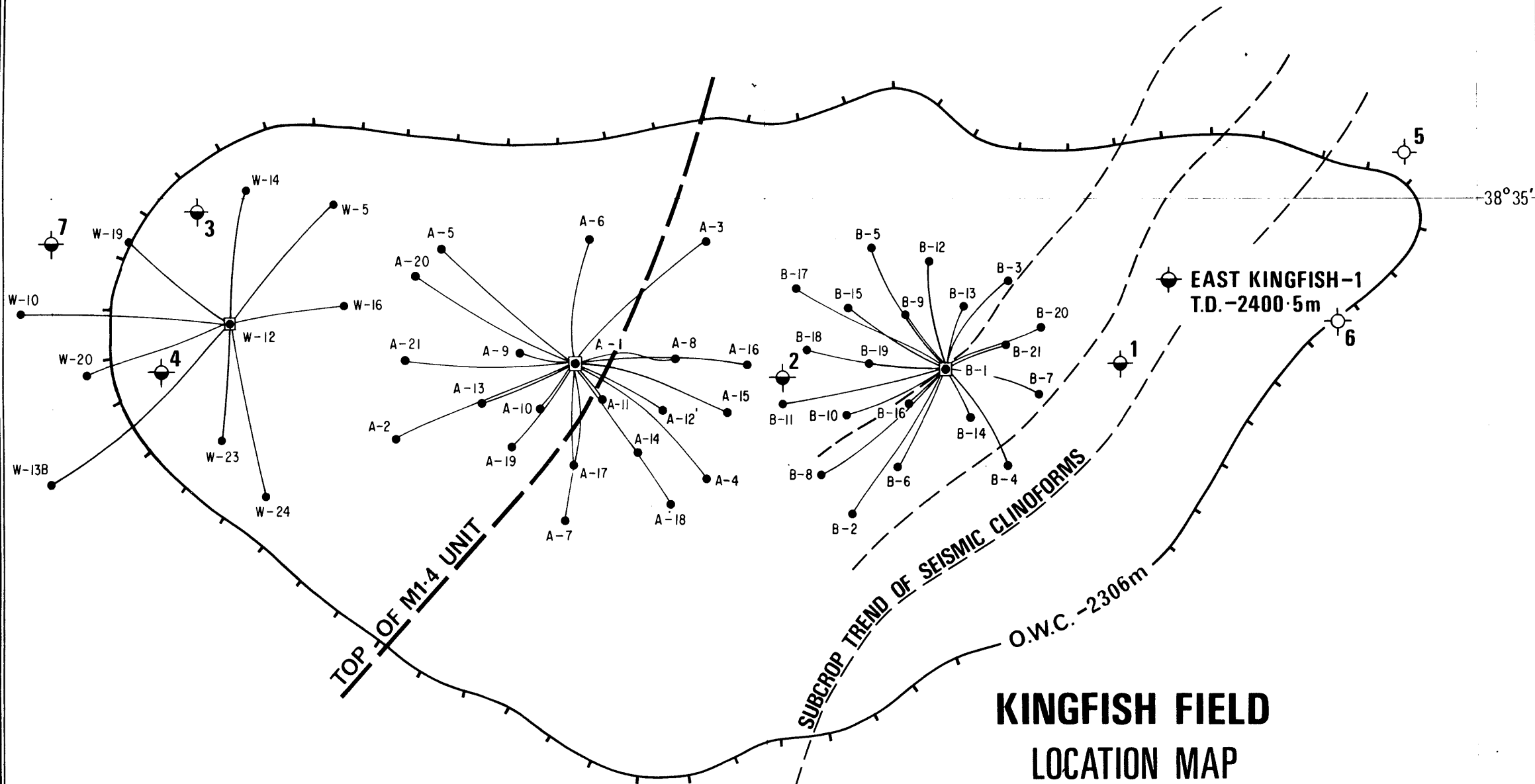

**EAST KINGFISH-1**  
T.D. -2400.5m

**TOP OF M1.4 UNIT**

**SUBCROP TREND OF SEISMIC CLINOFORMS**

# KINGFISH FIELD LOCATION MAP EAST KINGFISH-1

SCALE: 1 50 000



FIGURE 1

FIGURE 2

# WELL PROGRESS CURVE

WELL: EAST KINGFISH-1

RIG: SOUTHERN CROSS

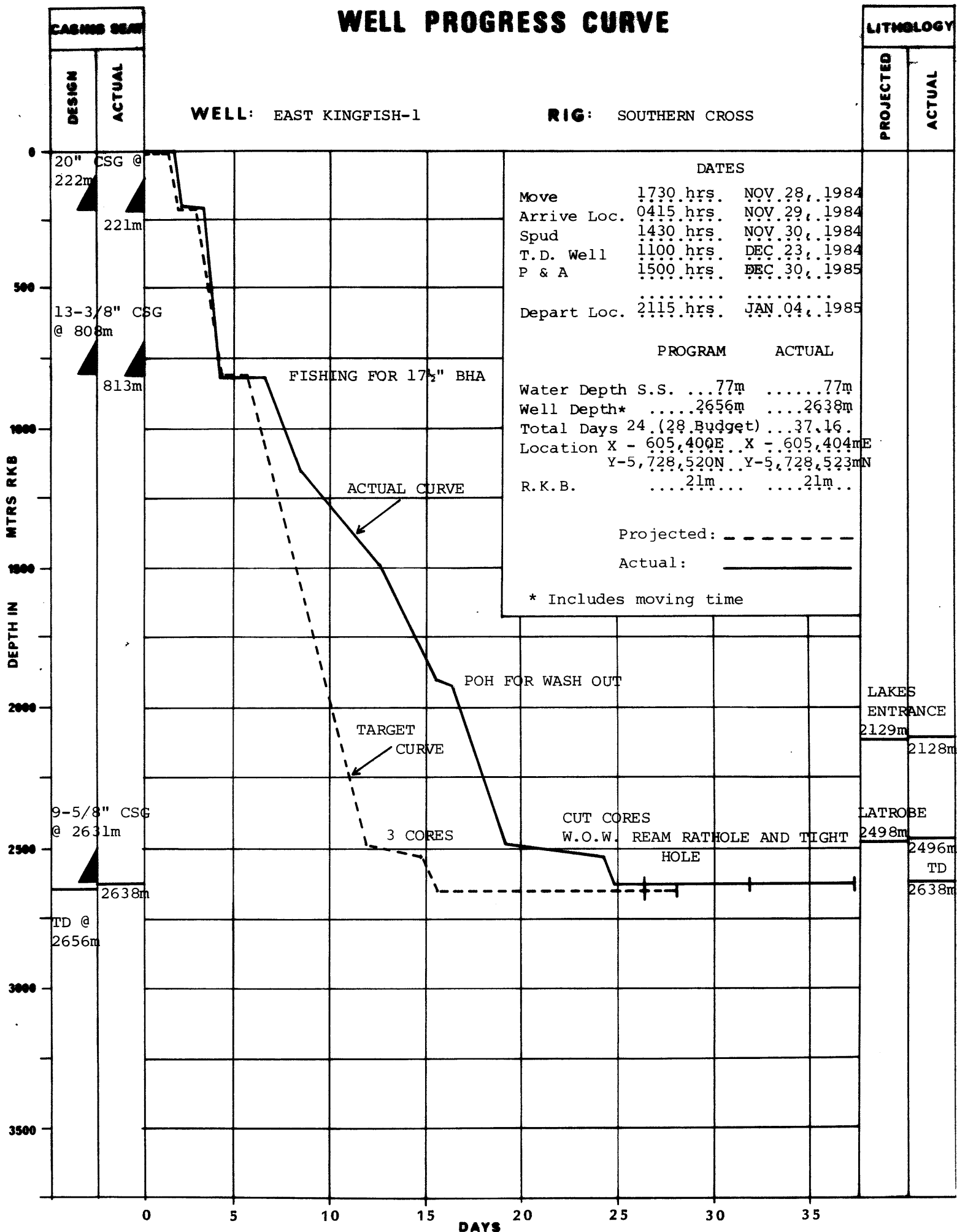
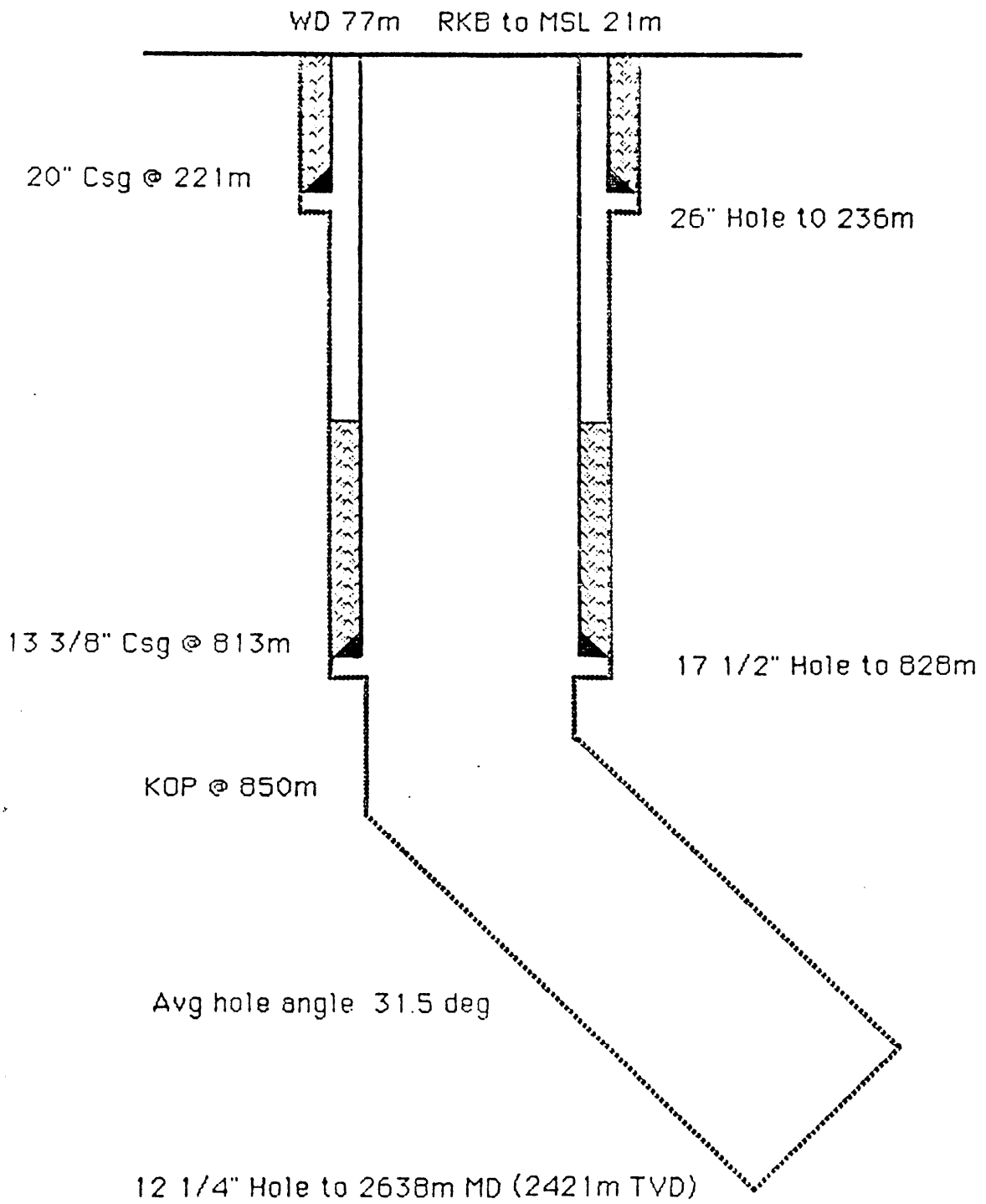





FIGURE 3  
EAST KINGFISH-1  
WELLBORE SCHEMATIC



 Primary Cement

ALL DEPTHS RELATIVE TO RKB

FIGURE 4

EAST KINGFISH-1  
ABANDONMENT SCHEMATIC

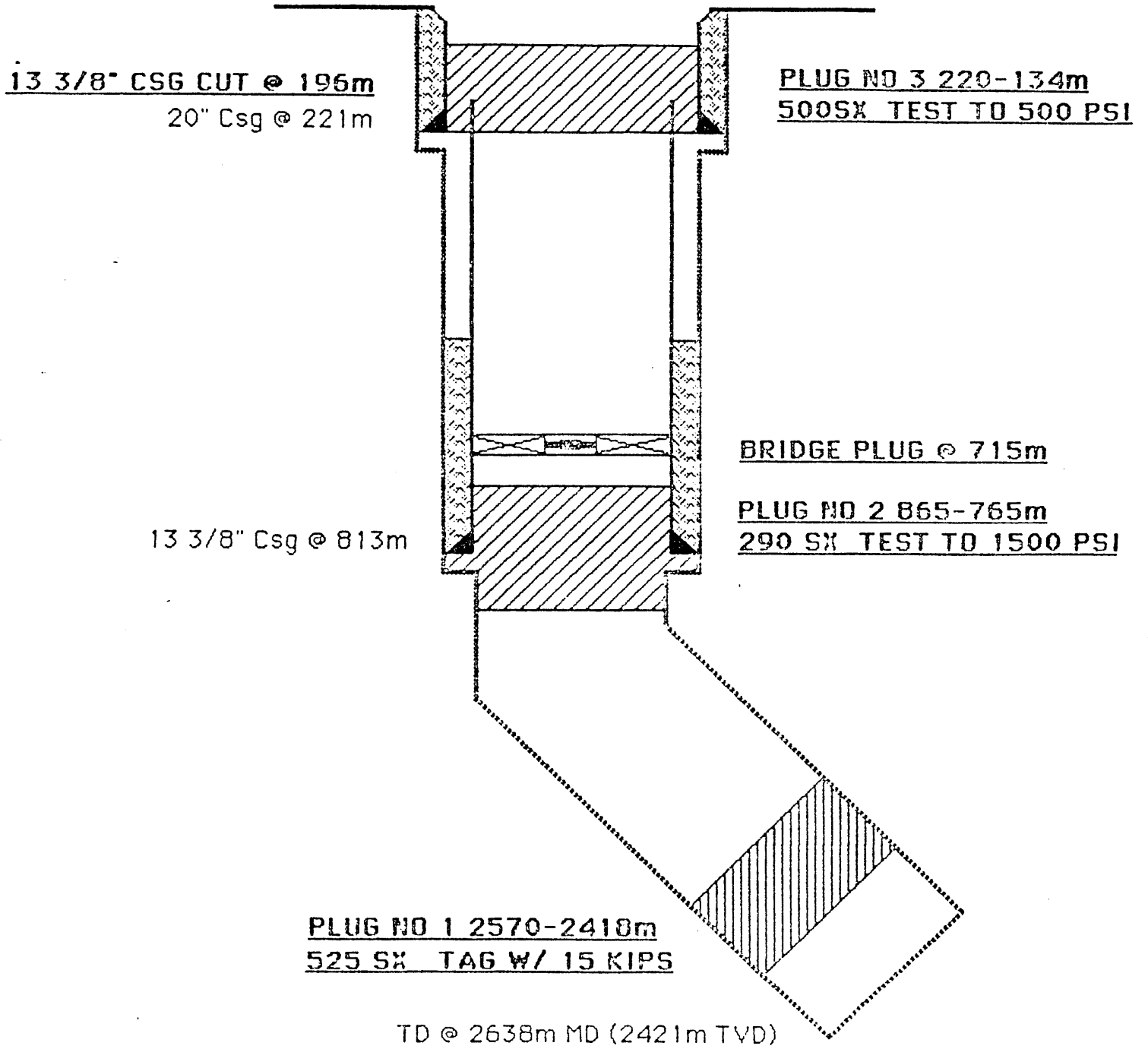



-  Primary Cement
-  P&A Cement

FIGURE 5



APPENDIX 1

EAST KINGFISH # 1

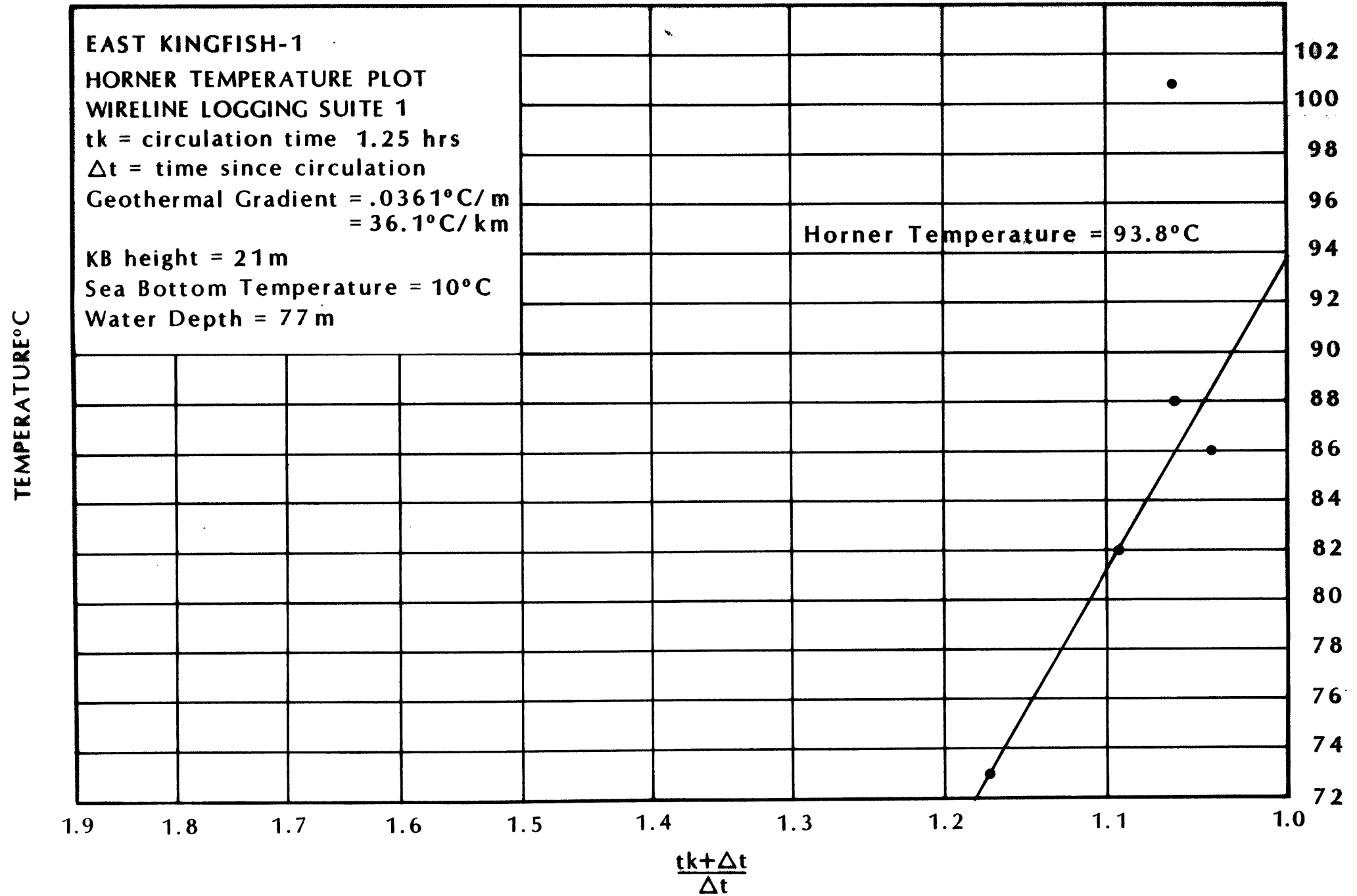
Lithology Descriptions

<u>Depth</u>	<u>%</u>	<u>Descriptions</u>
850.5 - 855m	100	LIMESTONE: off-white, light grey, soft to brittle, fine to very fine grained, calcisiltite - calcilutite. Contaminated by cement - phenol colour.
855 - 860m	100	LIMESTONE: as above. Cement contaminated.
860 - 865m	100	LIMESTONE: off-white, light grey/green, very soft, very fine grained calcilutite - minor calcisiltite - calcarenite.
865 - 870m	100	LIMESTONE: as above.
870 - 875m	100	LIMESTONE: as above. Minor calcisiltite.
875 - 880m	100	LIMESTONE: as above. More firm-brittle calcarenite, (very fine grained sandsize) - forams, calcarenite.
880 - 885m	100	LIMESTONE: as above.
885 - 890m	100	LIMESTONE: as above.
890 - 895m	100	LIMESTONE: as above.
895 - 900m	100	LIMESTONE: as above.
900 - 905m	100	LIMESTONE: as above.
905 - 910m	100	LIMESTONE: as above.
910 - 915m	100	LIMESTONE: as above. Minor calcarenite, fine to very fine grained.
915 - 920m	100	LIMESTONE: off-white, light grey, hard-soft, fine to very fine calcarenite and lesser calcisiltite and calcilutite - forams.
920 - 925m	100	LIMESTONE: as above.
925 - 930m	100	LIMESTONE: as above. Minor sparry calcite grains.
930 - 935m	100	LIMESTONE: as above.
935 - 940m	100	LIMESTONE: as above.
940 - 945m	100	LIMESTONE: as above. Trace pyrite, trace dull yellow, mineral fluorescence.
945 - 950m	100	LIMESTONE: as above. Trace calcite and aragonite crystal aggregates. Cephalopods.
950 - 955m	100	LIMESTONE: as above. Cephalopods, crinoids, corals.
	Trace	PYRITE.
955 - 960m	100	LIMESTONE: as above.

960 - 965m	100	LIMESTONE: as above.
965 - 970m	100 Trace	LIMESTONE: as above. Cephalopods, crinoids. PYRITE.
970 - 975m	100	LIMESTONE: as above. Cephalopods.
975 - 980m	100	LIMESTONE: as above.
980 - 985m	100	LIMESTONE: as above.
985 - 990m	100	LIMESTONE: as above.
990 - 995m	100 Trace Trace	LIMESTONE: as above. PYRITE. GLAUCONITE.
995 - 1000m	100	LIMESTONE: as above.
1000 - 1005m	100	LIMESTONE: light grey, soft to hard, fine to very fine grained calcarenite - calcisiltite, plus minor calicilutite. Minor dull yellow mineral fluorescence - no shows.
1005 - 1010m	100	LIMESTONE: as above.
1010 - 1015m	100	LIMESTONE: as above.
1015 - 1020	100	LIMESTONE: as above.
1020 - 1025m	100	LIMESTONE: as above.
1025 - 1030m	100	LIMESTONE: as above.
1030 - 1035m	100	LIMESTONE: as above.
1035 - 1040m	100	LIMESTONE: as above.
1040 - 1045m	100	LIMESTONE: as above.
1045 - 1050m	100	LIMESTONE: as above.
1050 - 1055m	100	LIMESTONE: as above.
1055 - 1060m	100	LIMESTONE: as above.
1060 - 1065m	100	LIMESTONE: as above.
1065 - 1070m	100	LIMESTONE: as above.
1070 - 1075m	100	LIMESTONE: as above. Dominantly fine grained, firm to hard, calcarenite. Trace dull, yellow mineral fluorescence.
1075 - 1080m	100	LIMESTONE: as above.
1080 - 1085m	100	LIMESTONE: as above.
1085 - 1090m	100	LIMESTONE: as above.
1090 - 1095m	100	LIMESTONE: as above.
1095 - 1100m	100	LIMESTONE: as above.

1100 - 1105m	100	LIMESTONE: light grey-white, fine grained, rounded to well rounded, well sorted calcarenite - minor calcisiltite, calcilutite.
	Trace	Fossil fragment.
1105 - 1110m	100	LIMESTONE: as above.
1110 - 1115m	100	LIMESTONE: as above. Fragments of brachiopods and other fossils.
1115 - 1120m	100	LIMESTONE: as above. Dominantly light grey in colour. Dull yellow mineral fluorescence becoming common.
1120 - 1125m	100	LIMESTONE: as above.
1125 - 1130m	100	LIMESTONE: as above.
1130 - 1135m	100	LIMESTONE: as above. Progressively becoming more like a packstone in texture. Minor percentage of calcarenite grading into a sandstone with carbonate cement, contains rounded to well rounded fine grained quartz aggregates.
1135 - 1140m	100	LIMESTONE: as above.
1140 - 1145m	100	LIMESTONE: as above.
1145 - 1150m	100	LIMESTONE: as above.
1150 - 1155m	100	LIMESTONE: as above.
1155 - 1160m	100	LIMESTONE: as above.
1160 - 1165m	100	LIMESTONE: as above.
1165 - 1170m	100	LIMESTONE: as above.
1170 - 1175m	100	LIMESTONE: as above.
1175 - 1180m	100	LIMESTONE: as above.
1180 - 1185m	100	LIMESTONE: as above. Slightly more calcisiltite.
1185 - 1190m	100	LIMESTONE: as above. Back to dominantly calcarenite.
1190 - 1195m	100	LIMESTONE: as above.
1195 - 1200m	100	LIMESTONE: as above.
1200 - 1205m	100	LIMESTONE: light grey - green grey, firm-soft, fine grained, rounded, well sorted, calcarenite - minor calcisiltite and calcilutite: Dull yellow mineral fluorescence present. Minor fossil fragments. No shows.
1205 - 1210m	100	LIMESTONE: as above.
1210 - 1215m	100	LIMESTONE: as above.
1215 - 1220m	100	LIMESTONE: as above.

1220 - 1225m	100	LIMESTONE: as above.
1225 - 1230m	100	LIMESTONE: as above.
1230 - 1235m	100	LIMESTONE: as above.
1235 - 1240m	100	LIMESTONE: as above.
1240 - 1245m	100	LIMESTONE: as above.
1245 - 1250m	100	LIMESTONE: as above.
1250 - 1255m	100	LIMESTONE: as above.
1255 - 1260m	100	LIMESTONE: as above.
1260 - 1265m	100	LIMESTONE: as above.
1265 - 1270m	100	LIMESTONE: as above.
1270 - 1275m	100	LIMESTONE: as above.
1275 - 1280m	100	LIMESTONE: as above.
1280 - 1285m	100	LIMESTONE: as above.
1285 - 1290m	100	LIMESTONE: as above, becoming much firmer - reflected in lower ROP's.
1290 - 1295m	100	LIMESTONE: as above.
1295 - 1300m	100	LIMESTONE: as above.
1300 - 1305m	100	LIMESTONE: medium to light grey, firm to very firm, very fine to fine grained calcarenite, trace calcisiltite, calcilutite. Trace dull yellow mineral fluorescence - no shows. Trace fossil fragments.
1305 - 1310m	100	LIMESTONE: as above.
1310 - 1315m	100	LIMESTONE: as above, minor calcisiltite.
1315 - 1320m	100	LIMESTONE: as above, minor common calcisiltite, soft.
1320 - 1325m	100	LIMESTONE: as above, minor calcisiltite.
1325 - 1330m	100	LIMESTONE: as above, minor calcisiltite.
1330 - 1335m	100	LIMESTONE: as above, minor calcisiltite.
1335 - 1340m	100	LIMESTONE: as above, minor calcisiltite.
1340 - 1345m	100	LIMESTONE: as above, minor calcisiltite.
1345 - 1350m	100	LIMESTONE: as above, minor calcisiltite.
1350 - 1355m	100	LIMESTONE: as above, minor calcisiltite.
1355 - 1360m	100	LIMESTONE: as above, trace calcisiltite.
1360 - 1365m	100	LIMESTONE: as above.



1365 - 1370m	100	LIMESTONE: as above.
1370 - 1375m	100	LIMESTONE: as above.
1375 - 1380m	100	LIMESTONE: as above.
1380 - 1385m	100	LIMESTONE: as above.
1385 - 1390m	100	LIMESTONE: as above, trace calcisiltite.
1390 - 1395m	100	LIMESTONE: as above, trace calcisiltite.
1395 - 1400m	100	LIMESTONE: as above.
1400 - 1405m	100	LIMESTONE: medium light grey, firm, rounded to well rounded, fine grained calcarenite, trace to minor calcisiltite and calcilutite. Trace dull yellow mineral fluorescence. No shows, trace fossil fragments.
1405 - 1410m	100	LIMESTONE: as above.
1410 - 1415m	100	LIMESTONE: as above.
1415 - 1420m	100	LIMESTONE: as above.
1420 - 1425m	100	LIMESTONE: as above.
1425 - 1430m	100	LIMESTONE: as above.
1430 - 1435m	100	LIMESTONE: as above, minor calcisiltite.
1435 - 1440m	100	LIMESTONE: as above, common calcisiltite, minor calcilutite.
1440 - 1445m	100	LIMESTONE: as above.
1445 - 1450m	100	LIMESTONE: as above.
1450 - 1455m	100	LIMESTONE: as above.
1455 - 1460m	100	LIMESTONE: as above.
1460 - 1465m	100	LIMESTONE: as above.
1465 - 1470m	100	LIMESTONE: as above.
1470 - 1475m	100	LIMESTONE: as above, minor calcilutite.
1475 - 1480m	100	LIMESTONE: as above.
1480 - 1485m	100	LIMESTONE: as above.
1485 - 1490m	100	LIMESTONE: as above.
1490 - 1495m	100	LIMESTONE: as above.
1495 - 1500m	100	LIMESTONE: as above.
1500 - 1505m	100	LIMESTONE: light to medium grey, soft to firm, very fine to fine grained, rounded to well rounded calcarenite. Minor calcisiltite and calcilutite. Minor dull yellow mineral fluorescence. No shows. Trace fossil fragments.

1505 - 1510m	100	LIMESTONE: as above.
1510 - 1515m	100	LIMESTONE: as above, calcisiltite, calcilutute common. Water sensitive, some clays present.
1515 - 1520m	100	LIMESTONE: as above, calcisiltite, calcilutite common.
1520 - 1525m	100	LIMESTONE: dominantly calcisiltite and calcilutite.
1525 - 1530m	100	LIMESTONE: dominantly calcisiltite and calcilutite, no mineral fluorescence.
1530 - 1535m	100	LIMESTONE: 50% light grey, soft calcilutite, calcisiltite and 50% olive grey, hard, fine to very fine grained calcarenite, slowly reactive in HCl, maybe some dolomite in this lithology ie. dolarenite.
1535 - 1540m	100	LIMESTONE: 95% light grey, soft calcilutite, calcisiltite and 5% olive grey, hard calcarenite.
1540 - 1545m	100	LIMESTONE: light grey, soft to firm calcisiltite, calcarenite. Minor olive grey, hard, calcarenite.
1545 - 1550m	100	LIMESTONE: as above.
1550 - 1555m	100	LIMESTONE: light to medium grey, soft to firm calcisiltite calcarenite.
1555 - 1560m	100	LIMESTONE: as above.
1560 - 1565m	100	LIMESTONE: as above.
1565 - 1570m	100	LIMESTONE: as above.
1570 - 1575m	100	LIMESTONE: as above.
1575 - 1580m	100	LIMESTONE: as above.
1580 - 1585m	100	LIMESTONE: as above.
1585 - 1590m	100	LIMESTONE: light to medium grey, firm, fine to very fine grained calcarenite, minor calcisiltite, calcilutite. Trace dull yellow mineral fluorescence. No shows.
1590 - 1595m	100	LIMESTONE: as above.
1595 - 1600m	100	LIMESTONE: as above, minor calcisiltite, calcilutite.
1600 - 1605m	100	LIMESTONE: as above.
1605 - 1610m	100	LIMESTONE: as above.
1610 - 1615m	100	LIMESTONE: as above.
1615 - 1620m	100	LIMESTONE: as above.
1620 - 1625m	100	LIMESTONE: as above.

1625 - 1630m	100	LIMESTONE: as above.
1630 - 1635m	100	LIMESTONE: as above.
1635 - 1640m	100	LIMESTONE: as above.
1640 - 1645m	100	LIMESTONE: as above.
1645 - 1650m	100	LIMESTONE: as above.
1650 - 1655m	100	LIMESTONE: as above.
1655 - 1660m	100	LIMESTONE: as above.
1660 - 1665m	100	LIMESTONE: as above.
1665 - 1670m	100	LIMESTONE: as above and minor calcisiltite, calcilutite.
1670 - 1675m	100	LIMESTONE: as above.
1675 - 1680m	100	LIMESTONE: as above.
1680 - 1685m	100	LIMESTONE: as above.
1685 - 1690m	100	LIMESTONE: as above.
1690 - 1695m	100	LIMESTONE: calcarenite and calcisiltite, calcilutite in roughly equivalent amounts.
1695 - 1700m	100	LIMESTONE: dominantly calcarenite, calcisiltite and calcilutite common.
1700 - 1705m	100	LIMESTONE: as above.
1705 - 1710m	100	LIMESTONE: as above.
1710 - 1715m	100	LIMESTONE: as above.
1715 - 1720m	100	LIMESTONE: trace thin (less than 1mm) dark green layers of glauconite.
1720 - 1725m	100	LIMESTONE: light to medium grey, firm to soft, very fine to fine grained calcarenite, minor calcilutite, calcisiltite. Trace thin (less than 1.0mm) bands of glauconite. Trace dull yellow mineral fluorescence. No shows.
1725 - 1730m	100	LIMESTONE: as above.
1730 - 1735m	100	LIMESTONE: dominantly light grey, very soft calcilutite with subordinate calcisiltite and calcarenite.
1735 - 1740m	100	LIMESTONE: as above, proportionately more calcisiltite.
1740 - 1745m	100	LIMESTONE: as above.
1745 - 1750m	100	LIMESTONE: dominantly calcilutite.
1750 - 1755m	100	LIMESTONE: dominantly calcilutite and calcisiltite and calcarenite common.
1755 - 1760m	100	LIMESTONE: as above.

1760 - 1765m	100	LIMESTONE: as above.
1765 - 1770m	100	LIMESTONE: as above.
1770 - 1775m	100	LIMESTONE: as above.
1775 - 1780m	100	LIMESTONE: as above.
1780 - 1785m	100	LIMESTONE: dominantly calcisiltite.
1785 - 1790m	100	LIMESTONE: dominantly calcisiltite.
1790 - 1795m	100	LIMESTONE: as above.
1795 - 1800m	100	LIMESTONE: becoming dominantly calcarenite.
1800 - 1805m	100	LIMESTONE: light to medium grey, firm to soft, very fine to fine grained calcarenite. Dull yellow mineral fluorescence common. Minor calcisiltite and calcilutite.
1805 - 1810m	100	LIMESTONE: as above.
1810 - 1815m	100	LIMESTONE: as above.
1815 - 1820m	100	LIMESTONE: as above.
1820 - 1825m	100	LIMESTONE: as above.
1825 - 1830m	100	LIMESTONE: as above.
1830 - 1835m	100	LIMESTONE: as above, calcisiltite more common.
1835 - 1840m	100	LIMESTONE: as above.
1840 - 1845m	100	LIMESTONE: as above.
1845 - 1850m	100	LIMESTONE: light to medium grey, firm to soft, fine to very fine grained calcarenite. Minor to common calcilutite, calcisiltite. Minor dull yellow mineral fluorescence. No shows.
1850 - 1855m	100	LIMESTONE: as above.
1855 - 1860m	100	LIMESTONE: as above, dull yellow mineral fluorescence common, no shows.
1860 - 1865m	100	LIMESTONE: as above.
1865 - 1870m	100	LIMESTONE: as above.
1870 - 1875m	100	LIMESTONE: as above.
1875 - 1880m	100	LIMESTONE: as above.
1880 - 1885m	100	LIMESTONE: as above, calcisiltite becoming more common.
1885 - 1890m	100	LIMESTONE: as above, calcisiltite still common, minor calcilutite.
1890 - 1895m	100	LIMESTONE: as above.

1895 - 1900m	100	LIMESTONE: as above, dominantly calcarenite, minor to common calcisiltite and calcilutite. Trace minor to common fossils, forams, fragments of cephalopods.
1900 - 1905m	100	LIMESTONE: as above, trace glauconite.
1905 - 1910m	100	LIMESTONE: as above.
1910 - 1915m	100	LIMESTONE: dominantly light grey, soft calcisiltite and calcilutite. Calcarenite common, containing minor glauconite. Forams common. Minor to trace dull yellow mineral fluorescence, no shows.
1915 - 1920m	100	LIMESTONE: dominantly calcilutite and calcisiltite, calcarenite minor.
1920 - 1925m	100	LIMESTONE: as above.
1925 - 1930m	100	LIMESTONE: calcilutite, minor calcisiltite, trace calcarenite.
1930 - 1935m	100	LIMESTONE: as above.
1935 - 1940m	100	LIMESTONE: as above.
1940 - 1945m	100	LIMESTONE: medium to light grey, soft to very soft calcilutite, minor calcisiltite and calcarenite. Fossil fragments common. Minor dull yellow mineral fluorescence, no shows.
1945 - 1950m	100	LIMESTONE: as above, minor pyrite nodules.
1950 - 1955m	100	LIMESTONE: as above, minor pyrite nodules replacing fossils.
1955 - 1960m	100	LIMESTONE: as above.
1960 - 1965m	100	LIMESTONE: as above.
1965 - 1970m	100	LIMESTONE: as above.
1970 - 1975m	100	LIMESTONE: as above.
1975 - 1980m	100	LIMESTONE: as above.
1980 - 1985m	100	LIMESTONE: as above.
1985 - 1990m	100	LIMESTONE: as above.
1990 - 1995m	100	LIMESTONE: as above.
1995 - 2000m	100	LIMESTONE: as above.
2000 - 2005m	100	LIMESTONE: as above, pyrite nodules common.
2005 - 2010m	100	LIMESTONE: as above.
2010 - 2015m	100	LIMESTONE: as above.
2015 - 2020m	100	LIMESTONE: as above.
2020 - 2025m	100	LIMESTONE: as above.

2025 - 2030m	100	LIMESTONE: as above.
2030 - 2035m	100	LIMESTONE: as above, minor pyrite nodules.
2035 - 2040m	100	LIMESTONE: dominantly calcilutite, minor calcarenite, minor pyrite nodules, also fossil fragments. Minor dull yellow mineral fluorescence.
2040 - 2045m	40	SILTSTONE: dark grey, firm, very fine grained calcareous siltstone.
	60	LIMESTONE: medium to light grey calcilutite, soft to very soft. Fossil fragments common. Pyrite nodules common.
2045 - 2050m	80	SILTSTONE: dark to medium grey, firm, very fine grained, well sorted calcareous siltstone, minor fossils, trace pyrite.
	20	LIMESTONE: light to medium grey, very soft calcilutite, fossil fragments common, minor pyrite. Trace dull yellow mineral fluorescence.
2050 - 2055m	40	SILTSTONE: as above.
	60	LIMESTONE: as above.
2055 - 2060m	20	SILTSTONE: as above.
	80	LIMESTONE: as above.
2060 - 2065m	95	LIMESTONE: dominantly light grey, very fine to fine grained, well rounded to rounded calcarenite, minor to common calcisiltite and calcilutite.
	5	SILTSTONE: as above.
2065 - 2070m	95	LIMESTONE: as above, calcilutite, calcisiltite more common.
	5	SILTSTONE: as above.
2070 - 2075m	95	LIMESTONE: as above, very little calcisiltite and calcilutite.
	5	SILTSTONE: as above.
2075 - 2080m	100	LIMESTONE: as above, calcilutite common.
2080 - 2085m	100	LIMESTONE: dominantly light grey, soft to very soft calcilutite, minor calcarenite.
2085 - 2090m	10	SILTSTONE: dark to medium grey, firm, very fine grained, well sorted calcareous siltstone.
	90	LIMESTONE: dominantly light to medium grey, very fine grained calcisiltite common, minor calcarenite and calcilutite.
2090 - 2095m	60	SILTSTONE: dark to medium grey, very fine grained, firm, calcareous siltstone.
	40	LIMESTONE: dominantly light to medium grey calcisiltite, minor to common calcilutite.
2095 - 2100m	80	SILTSTONE: as above.
	20	LIMESTONE: as above.
2100 - 2105m	100	SILTSTONE: as above.
2105 - 2110m	100	SILTSTONE: as above, becoming more calcareous.

2110 - 2115m	80	SILTSTONE: dark to medium grey, firm, very fine grained, well sorted calcareous siltstone. Fossil fragments common. Pyrite nodules common. Trace dull yellow mineral fluorescence, no shows.
	20	LIMESTONE: dominantly light grey, soft calcilutite. Fossil fragments common.
2115 - 2120m	90	SILTSTONE: as above.
	10	LIMESTONE: as above.
2120 - 2125m	80	SILTSTONE: as above.
	20	LIMESTONE: as above.
2125 - 2130m	50	SILTSTONE: as above.
	50	LIMESTONE: as above, calcisiltite dominant.
2130 - 2135m	70	SILTSTONE: as above.
	30	LIMESTONE: as above.
2135 - 2140m	90	SILTSTONE: as above.
	10	LIMESTONE: as above.
2140 - 2145m	90	SILTSTONE: as above.
	10	LIMESTONE: as above.
2145 - 2150m	90	SILTSTONE: as above.
	10	LIMESTONE: as above.
2150 - 2155m	85	SILTSTONE: as above.
	15	LIMESTONE: as above.
2155 - 2160m	80	SILTSTONE: as above.
	20	LIMESTONE: as above, calcisiltite dominant, calcarenite common.
2160 - 2165m	60	SILTSTONE: as above.
	40	LIMESTONE: as above.
2165 - 2170m	100	LIMESTONE: calcisiltite and calcareous siltstone. Minor to common calcilutite.
2170 - 2175m	20	SILTSTONE: as above.
	80	LIMESTONE: as above.
2175 - 2180m	40	SILTSTONE: as above.
	60	LIMESTONE: as above.
2180 - 2185m	70	LIMESTONE: light grey, soft to firm calcilutite and calcisiltite. Minor fossil fragments and pyrite nodules.
	30	SILTSTONE: dark grey, firm to hard, very fine grained well sorted calcareous siltstone. Minor fossil fragments.
2185 - 2190m	90	SILTSTONE: as above.
	10	LIMESTONE: as above.
2190 - 2195m	85	SILTSTONE: as above.
	15	LIMESTONE: as above, calcarenite more common.
2195 - 2200m	75	SILTSTONE: as above.
	25	LIMESTONE: as above.

2200 - 2205m	65 35	SILTSTONE: as above. LIMESTONE: as above.
2205 - 2210m	90 10	SILTSTONE: as above. LIMESTONE: as above.
2210 - 2215m	100	SILTSTONE: as above.
2215 - 2220m	100	SILTSTONE: as above.
2220 - 2225m	60 40	SILTSTONE: as above. LIMESTONE: as above.
2225 - 2230m	50 50	SILTSTONE: as above. LIMESTONE: as above.
2230 - 2235m	35 65	SILTSTONE: as above. LIMESTONE: as above.
2235 - 2240m	40 60	SILTSTONE: as above. LIMESTONE: as above.
2240 - 2245m	60 40	SILTSTONE: as above, trace glauconite. LIMESTONE: as above, dominantly soft calcarenite.
2245 - 2250m	80 20	SILTSTONE: as above. LIMESTONE: as above.
2250 - 2255m	90 10	SILTSTONE: as above. LIMESTONE: as above.
2255 - 2260m	75 25	SILTSTONE: as above. LIMESTONE: as above.
2260 - 2265m	60	SILTSTONE: dark grey, firm to hard, very fine grained, well sorted calcareous siltstone. Trace fossil fragments.
	40	LIMESTONE: light grey, soft to very soft calcisiltite. Common fossil fragments, trace pyrite nodules.
2265 - 2270m	50 50	SILTSTONE: as above, becoming sandy. LIMESTONE: as above, trace dull yellow mineral fluorescence.
2270 - 2275m	70 30	SILTSTONE: as above. LIMESTONE: as above.
2275 - 2280m	65 35	SILTSTONE: as above. LIMESTONE: as above.
2280 - 2285m	60 40	SILTSTONE: as above. LIMESTONE: as above.
2285 - 2290m	40 60	SILTSTONE: as above. LIMESTONE: as above.
2290 - 2295m	45 55	SILTSTONE: as above. LIMESTONE: as above.
2295 - 2300m	80 20	SILTSTONE: as above. LIMESTONE: as above.



2300 - 2305m	70 30	SILTSTONE: as above. LIMESTONE: as above.
2305 - 2310m	80 20	SILTSTONE: as above. LIMESTONE: as above.
2310 - 2315m	80 20	SILTSTONE: as above. LIMESTONE: as above.
2315 - 2320m	90 10	SILTSTONE: as above. LIMESTONE: as above.
2320 - 2325m	90 10	SILTSTONE: as above. LIMESTONE: as above.
2325 - 2330m	80 20	SILTSTONE: as above. LIMESTONE: as above.
2330 - 2335m	75  25	SILTSTONE: dark grey, firm to hard, well sorted, calcareous siltstone. Minor fossil fragments, trace glauconite. LIMESTONE: light grey to off white, soft to very soft calcarenite and calcisiltite, fossils common, trace pyrite.
2335 - 2340m	75 25	SILTSTONE: as above. LIMESTONE: as above.
2340 - 2345m	70 30	SILTSTONE: as above. LIMESTONE: as above.
2345 - 2350m	85 15	SILTSTONE: as above. LIMESTONE: as above.
2350 - 2355m	60 40	SILTSTONE: as above. LIMESTONE: as above, dominantly calcarenite.
2355 - 2360m	50 50	SILTSTONE: as above. LIMESTONE: as above.
2360 - 2365m	80 20	SILTSTONE: as above. LIMESTONE: as above.
2365 - 2370m	80 20	SILTSTONE: as above. LIMESTONE: as above.
2370 - 2375m	75 25	SILTSTONE: as above. LIMESTONE: as above.
2375 - 2380m	70 30	SILTSTONE: as above. LIMESTONE: as above.
2380 - 2385m	70 30	SILTSTONE: as above. LIMESTONE: as above.
2385 - 2390m	80 20	SILTSTONE: as above. LIMESTONE: as above.
2390 - 2395m	80 20	SILTSTONE: as above. LIMESTONE: as above.
2395 - 2400m	80 20	SILTSTONE: as above. LIMESTONE: as above.

2400 - 2405m	70	SILTSTONE: dark grey, firm to hard, fine grained, well sorted, calcareous, sandy siltstone. Trace fragments of fossils.
	30	LIMESTONE: light grey, firm to soft calcisiltite, calcarenite and minor calcilutite. Fossil fragments common - minor. Trace pyrite nodules.
2405 - 2410m	65	SILTSTONE: as above.
	35	LIMESTONE: as above, trace glauconite.
2410 - 2415m	80	SILTSTONE: as above.
	20	LIMESTONE: as above.
2415 - 2420m	80	SILTSTONE: as above.
	20	LIMESTONE: as above.
2420 - 2425m	60	SILTSTONE: as above.
	40	LIMESTONE: as above.
2425 - 2430m	50	SILTSTONE: as above.
	50	LIMESTONE: as above.
2430 - 2435m	70	SILTSTONE: as above.
	30	LIMESTONE: as above.
2435 - 2440m	80	SILTSTONE: as above.
	20	LIMESTONE: as above.
2440 - 2445m	70	SILTSTONE: as above.
	30	LIMESTONE: as above, dominantly calcarenite.
2445 - 2450m	70	SILTSTONE: as above.
	30	LIMESTONE: as above.
2450 - 2455m	60	SILTSTONE: as above.
	40	LIMESTONE: as above.
2455 - 2460m	60	SILTSTONE: as above, very calcareous.
	40	LIMESTONE: as above.
2460 - 2465m	80	SILTSTONE: as above, very calcareous grading to calcisiltite.
	20	LIMESTONE: as above.
2465 - 2470m	80	SILTSTONE: dark grey, hard, calcareous, grading to calcisiltite, sandy in part, well sorted, well rounded.
	20	LIMESTONE: light to medium grey, soft to firm, subcrystalline in part (calcilutite).
2470 - 2475m	90	CALCISILTITE: as for siltstone as above, but very calcareous. Occasionally grades to siltstone.
	10	LIMESTONE: as above.
2475 - 2480m	100	CALCISILTITE: as above, rare glauconite.
	trace	LIMESTONE: as above.
2480 - 2485m	100	CALCISILTITE: as above, rare glauconite and calcarenite.
	trace	LIMESTONE: as above.
2485 - 2490m	100	CALCISILTITE: as above.
	trace	FOSSILS: forams

2490 - 2495m	100 trace	CALCISILTITE: as above, trace glauconite. SANDSTONE: unconsolidated quartz grains, well rounded, clear, medium to coarse grained.  Cut Core No. 1 2496-2502m Cut Core No. 2 2502-2512m Cut Core No. 3 2512-2521.4m Cut Core No. 4 2521.4-2530.4m
2530.4-2535m	30  70	SANDSTONE: unconsolidated quartz grains, clear to milky white, medium to coarse grained, subrounded, well sorted, rare pyrite, good inferred visual porosity. No shows. CAVINGS: calcisiltite - medium grey, very calcareous, firm, sandy in part, rare fossils.
2535 - 2540m	30 70	SANDSTONE: predominantly coarse grained otherwise as above. No shows. CALCISILTITE: as above, cavings.
2540 - 2545m	90  10	SANDSTONE: unconsolidated quartz grains, clear to milky white, coarse grained, rounded, well sorted, good to excellent inferred visual porosity, no shows. CAVINGS: calcisiltite - as above.
2545 - 2550m	90 10 trace	SANDSTONE: as above, no shows. CAVINGS: calcisiltite - as above. SILTSTONE: reddish brown, firm, subfissile, argillaceous, micromicaceous, non calcareous, disseminated pyrite.
2550 - 2555m	100  trace	SANDSTONE: unconsolidated clear to milky white quartz grains, subangular to rounded, well sorted, coarse to occasionally very coarse grained, good to excellent inferred visual porosity. No shows. CALCISILTITE: cavings - as above.
2555 - 2560m	100  trace	SANDSTONE: as above, except very coarse grained, clear to milky quartz grains. No shows. CALCISILTITE: cavings - as above.
2560 - 2565m	100  trace	SANDSTONE: unconsolidated clear to milky white quartz grains, coarse to very coarse grained, rounded to well rounded, well sorted, good to excellent inferred visual porosity, no shows. CALCISILTITE: cavings - as above.
2565- 2570m	100	SANDSTONE: unconsolidated clear to milky white quartz grains, coarse to very coarse grained, rounded to well rounded, well sorted, good to excellent visual porosity, no shows.
2570 - 2575m	100	SANDSTONE: as above, no shows.
2575 - 2580m	100 trace  trace	SANDSTONE: as above, no shows. SILTSTONE: medium grey, firm to soft, argillaceous, slightly carbonaceous, grading to coal. COAL: black, silty, angular cuttings.
2580 - 2585m	100 trace	SANDSTONE: as above, no shows. SILTSTONE: as above.

2585 - 2590m	100	SANDSTONE: unconsolidated clear to milky white quartz grains, coarse to very coarse grained, subrounded to rounded to occasionally well rounded, well sorted, good to excellent visual porosity, no shows.
	trace	SILTSTONE: as above.
2590 - 2595m	100	SANDSTONE: unconsolidated clear to milky white quartz grains, coarse to very coarse grained, subrounded to rounded, moderately well sorted, good to excellent visual porosity, no shows.
	trace	SILTSTONE: medium grey to light grey, argillaceous, becoming sandy in part, angular to subangular cuttings.
2595 - 2600m	100	SANDSTONE: as above, no shows.
	trace	SILTSTONE: as above.
2600 - 2605m	100	SANDSTONE: as above, no shows.
	trace	SILTSTONE: as above.
2605 - 2610m	100	SANDSTONE: as above, no shows.
	trace	SILTSTONE: as above.
2610 - 2615m	100	SANDSTONE: as above, no shows.
	trace	SILTSTONE: as above.
2615 - 2620m	100	SANDSTONE: as above, no shows, minor nodular pyrite.
	trace	SILTSTONE: as above.
2620 - 2625m	100	SANDSTONE: unconsolidated clear to milky white quartz grains, coarse to very coarse grained, subrounded to rounded, moderately well sorted, good to excellent visual porosity, no shows, minor pyritic nodules and cement.
	trace	SILTSTONE: as above.
2625 - 2630m	100	SANDSTONE: unconsolidated clear to milky quartz grains, coarse to very coarse grained, subangular to rounded, occasionally well rounded; moderately to moderately well sorted, good to excellent visual porosity, no shows.
	trace	SILTSTONE: as above.
2630 - 2635m	100	SANDSTONE: as above, no shows, minor silica and pyritic cement.
	trace	SILTSTONE: as above.
2635 - 2638m	100	SANDSTONE: unconsolidated clear to milky quartz grains, coarse to very coarse grained, subangular to rounded, occasionally well rounded; moderately to moderately well sorted, minor silica and pyritic cement, good to excellent visual porosity, no shows.
	trace	SILTSTONE: as above.

T.D. at 2638m MD

APPENDIX 2

Core No. 1

Well : EAST KINGFISH-1

Interval Cored : 2496.0 - 2502.0m

Cut : 6m

Recovered : 3.83m (63.8%)

Bit Type : CT-320

Bit Size : 8-1/2"

Described by : M. Sloan

Date : 19/12/84

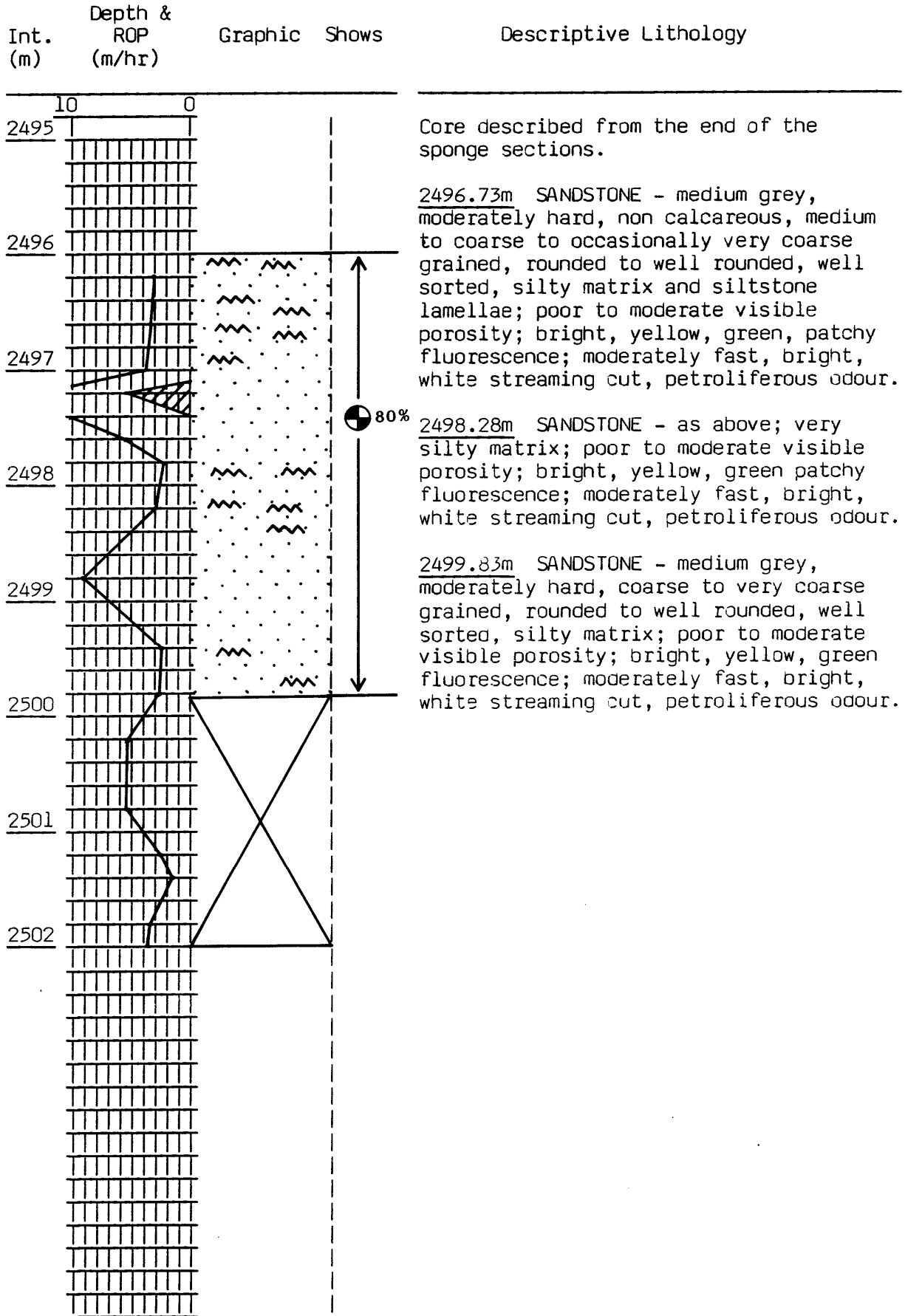

Core No. 2

Well : EAST KINGFISH-1

Interval Cored : 2502.0 - 2512.0m

Cut : 10.0m

Recovered : 9.1m (91%)

Bit Type : RC-4

Bit Size : 9-7/8"

Described by : M. Sloan

Date : 21/12/84

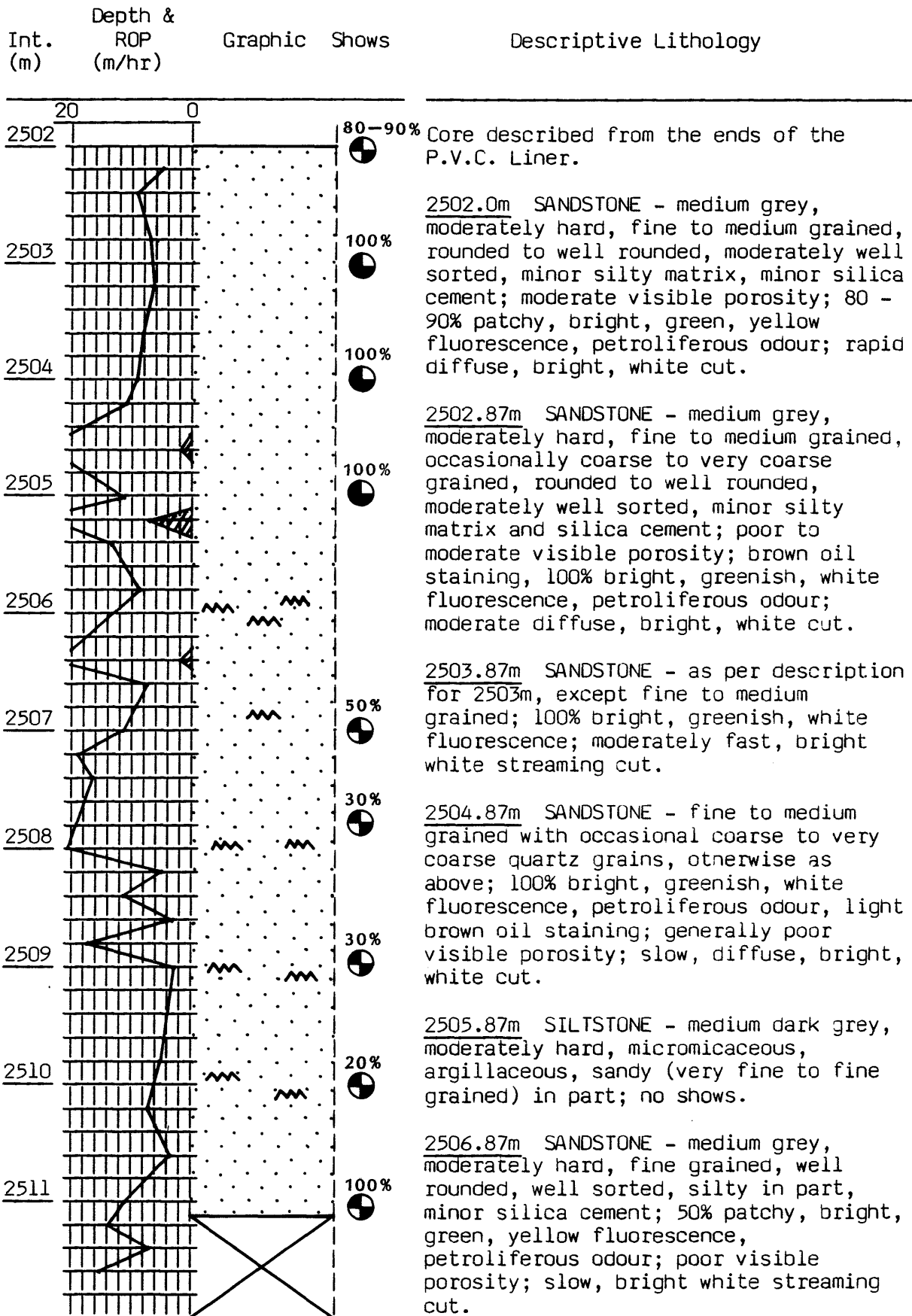

Core No. 2 cont'd

Well : EAST KINGFISH-1

Interval Cored : 2502.0 - 2512.0m

Cut : 10.0m

Bit Type : RC-4

Described by : M. Sloan

Recovered : 9.1m (91%)

Bit Size : 9-7/8"

Date : 21/12/84

Int. (m)	Depth & ROP (m/hr)	Graphic Shows	Descriptive Lithology
			<p><u>2507.87m</u> SANDSTONE - medium grey, moderately hard, fine grained to occasionally medium to coarse grained, rounded to well rounded, moderately well sorted, very silty matrix, minor silica cement; poor visible porosity; 30% patchy, bright, green, yellow fluorescence, petroliferous odour; instantaneous diffuse, bright, white crush cut.</p>
			<p><u>2508.87m</u> SANDSTONE - as per description for 2508.0m with siltstone lamellae; poor visible porosity; 30% patchy, bright, green, yellow fluorescence, petroliferous odour; moderately slow, bright, white streaming cut.</p>
			<p><u>2509.87m</u> SANDSTONE - as per description for 2508.0m; very silty matrix; poor visible porosity; 20% patchy, bright, yellow, white fluorescence, petroliferous odour; slow, bright, white streaming cut; instantaneous diffuse, bright, white crush cut.</p>
			<p><u>2510.90m</u> SANDSTONE - medium light grey, moderately hard, fine to medium grained, rounded to well rounded, well sorted, minor silica cement; moderate visible porosity; 100% even, bright, white fluorescence; instantaneous, bright, white, diffuse cut.</p>



Core No. 3

Well : EAST KINGFISH-1

Interval Cored : 2512.0 - 2521.4m

Cut : 9.4m

Recovered : 0.62m (6%)

Bit Type : CT 320

Bit Size : 8-1/2"

Described by : M. Sloan

Date : 21/12/84

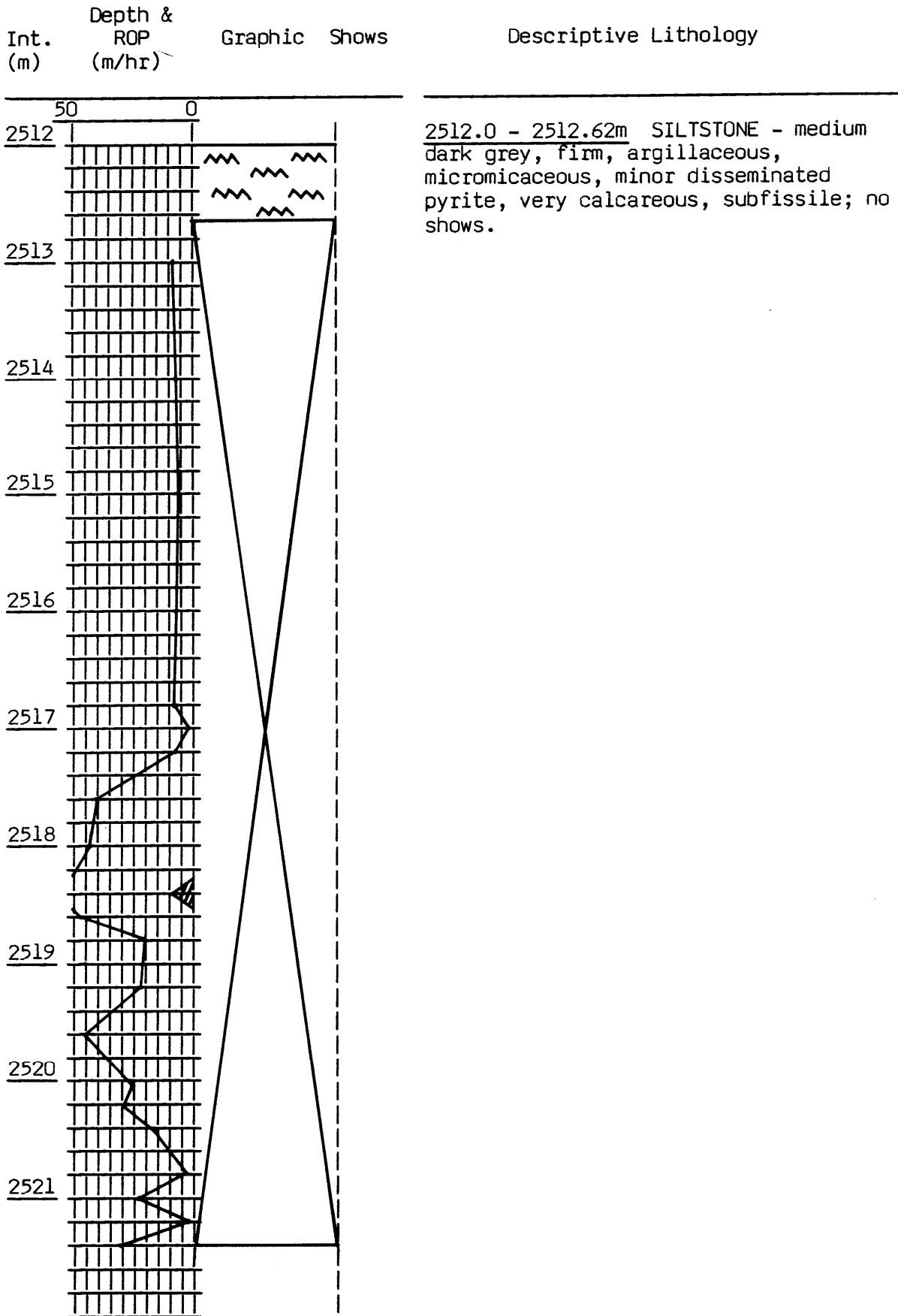

Core No. 4

Well : EAST KINGFISH-1

Interval Cored : 2521.4 - 2530.4m

Cut : 9.0m

Recovered : 9.0m (100%)

Bit Type : RC-4

Bit Size : 9-7/8"

Described by : M. Sloan

Date : 22/12/84

Int. (m)	Depth & ROP (m/hr)	Graphic Shows	Descriptive Lithology
2521			Core described from the ends of the P.V.C. Liners.
2522		100%	2521.4m SANDSTONE - medium grey, friable to unconsolidated quartz, medium to occasionally coarse grained, subangular to rounded, well sorted; good to excellent visible porosity; 100% even, bright, white fluorescence, petroliferous odour; fast, bright, white streaming cut.
2523		100%	2522.4m SANDSTONE - medium grey, unconsolidated to friable, medium to coarse quartz grained, rounded to well rounded, well sorted; excellent visible porosity; 100% even, bright, white fluorescence, petroliferous odour; fast, bright, white streaming cut.
2524		100%	2523.4m SANDSTONE - as per description for 2522.4m; 100% even, bright, white fluorescence, petroliferous odour; fast, bright, white streaming cut.
2525			2524.4m SANDSTONE - as per description for 2522.4m; 100% bright, white fluorescence, petroliferous odour; fast, bright, white streaming cut.
2526			2525.4m SANDSTONE - as per description for 2522.4m; no shows.
2527			2526.4m SANDSTONE - medium dark grey, friable to unconsolidated, medium quartz grained, rounded to well rounded, well sorted; moderate to good visible porosity; no shows.
2528			2527.4m SANDSTONE - medium light grey, friable to unconsolidated, fine to occasionally medium grained, subangular to subrounded to occasionally rounded, well sorted; moderate to good visible porosity; no shows.
2529			2528.4m SANDSTONE - medium dark grey, friable, medium grained, subangular to rounded, moderately sorted, very silty matrix; poor visible porosity; no shows.
2530			

Core No. 4 cont'd

Well : EAST KINGFISH-1

Interval Cored : 2521.4 - 2530.4m

Cut : 9.0m

Recovered : 9.0m (100%)

Bit Type : RC-4

Bit Size : 9-7/8"

Described by : M. Sloan

Date : 22/12/84

Int. (m)	Depth & ROP (m/hr)	Graphic	Shows	Descriptive Lithology
				<p>2529.4m SANDSTONE - medium dark grey, firm, very fine to fine quartz grains, subangular to subrounded, moderately sorted, very silty matrix, siltstone lamellae; poor visible porosity; no shows.</p> <p>2530.4m SANDSTONE - medium light grey, unconsolidated to friable, medium to coarse grained, subrounded to well rounded, well sorted; good to excellent visible porosity; no shows.</p>

APPENDIX 3

EAST KINGFISH 1

SIDEWALL CORE DESCRIPTIONS

<u>No.</u>	<u>Depth</u>	<u>Rec.</u> <u>(mm)</u>	<u>Rock</u> <u>Type</u>	<u>Description</u>
1	2617.55	38	Sandstone	Medium grey, medium to coarse grained, moderately sorted, subrounded, friable, minor silty matrix.
2	2610.59	38	Sandstone	Medium grey, medium to coarse grained, moderately sorted, subrounded, friable, minor silty matrix, minor silica cement.
3	2590.54	35	Sandstone	Medium grey, medium to coarse grained, moderately sorted, subrounded, friable, minor silty matrix.
4	2576.36	37	Sandstone	Medium grey, coarse to very coarse grained, well sorted, rounded, friable, minor silty matrix.
5	2571.82	40	Sandstone	Medium grey, medium to coarse grained, moderately sorted, subrounded, friable, minor silty matrix.
6	2549.09	35	Sandstone	Medium grey, coarse to very coarse grained, well sorted, rounded, friable.
7	2537.07	36	Sandstone	Medium grey, coarse to very coarse grained, well sorted, rounded, friable.
8	2535.06	40	Sandstone	Medium grey, coarse to very coarse grained, well sorted, rounded, friable.
9	2533.17	38	Sandstone	Medium grey, fine grained, well sorted, subrounded, friable, silty matrix, micromicaceous.
10	2531.17	35	Sandstone	Medium grey, fine to medium grained, moderately sorted, subrounded, friable, silty, micromicaceous, siltstone lamellae.
11	2519.02	40	Sandstone	Medium light grey, medium grained, well sorted, rounded, friable; 100% even dull white fluorescence, moderate slow white streaming cut.
12	2516.11	35	Sandstone	Medium light grey, medium grained, well sorted, rounded, friable; 100% even dull white fluorescence, moderately slow white streaming cut.
13	2497.01	43	Sandstone	Medium grey, very fine to fine grained, moderately sorted, subrounded, friable, slightly calcareous, silty; 80% patchy bright greenish yellow fluorescence, moderately slow white streaming cut.
14	2496.02	42	Sandstone	Medium grey, fine to coarse grained, poorly sorted, subangular, medium to hard, glauconite, silty, gypsum.

15	2495.06	45	Sandstone	Green grey, coarse grained, poorly sorted, subrounded, firm, glauconitic, silty.
16	2493.91	50	Sandstone	Green grey, very fine to fine grained, moderately sorted, subrounded, firm, glauconitic, silty, pyritic.
17	2493.06			Empty
18	2492.07			Shot Off
19	2491.06	45	Sandstone	Medium grey, very fine to fine grained, moderately sorted, subrounded, firm, very calcareous, silty, subfissile in part, micromicaceous.
20	2490.06			Shot Off
21	2489.09			Shot Off
22	2488.01			Shot Off
23	2485.15			Shot Off
24	2480.08	60	Siltstone/ Claystone	Medium dark grey, firm, very calcareous, argillaceous, subfissile.
25	2475.03	35	Siltstone/ Claystone	Medium dark grey, firm, very calcareous, argillaceous, subfissile.
26	2460.08			Shot Off
27	2455.08			Shot Off
28	2450.05	42	Siltstone/ Claystone	Medium dark grey, firm, very calcareous, argillaceous, subfissile.
29	2445.09	25	Siltstone/ Claystone	Medium dark grey, firm, very calcareous, argillaceous, subfissile.
30	2440.01	35	Siltstone/ Claystone	Medium dark grey, firm, very calcareous, argillaceous, subfissile.

24141/20-21

APPENDIX 4

EAST KINGFISH-1  
SIDEWALL CORE GAS ANALYSIS

NO.	DEPTH	C1	C2	C3	C4	C5	C6	
1	2617.55	19	11	14	7	5	4	
2	2610.59	39	31	27	44	26	20	
3	2590.54	24.6	11.24	16.03	7	3	3	
4	2576.36	34	11	16	5	2	2	
5	2571.82	83	20	9	trace			
6	2549.09	89	56	21	2	2		
7	2537.07	39	20	9	trace	trace		
8	2535.06	25	8	5	trace			
9	2533.17	29	48	64	31	18	13	
10	2531.17	47	146	160	76	39	27	
11	2519.02	100	324	385	147	85	54	
12	2516.11	944	1618	1025	568	576	trace	
13	2497.01	7557	12150	8400	3900	3850	480	
14	2496.02	8501	12229	5569	2131	2960	1720	
15	2495.08	314	539	293	284	132	trace	
16	2493.91	708	324	219	124	82	48	
17	2493.06	78	45	37	18	21	27	
18	2492.07		M I S F I R E					
19	2491.06	59	22	14	4	1	trace	
20	2490.06		M I S F I R E					
21	2489.09		M I S F I R E					
22	2488.01		M I S F I R E					
23	2485.15	65	55	30	10	7	trace	
24	2480.08	88	62	39	16	13	13	
25	2475.03	540	359	185	85	65	trace	



EAST KINGFISH-1  
SIDEWALL CORE GAS ANALYSIS

NO.	DEPTH	C1	C2	C3	C4	C5	C6
26	2460.08			M I S F I R E			
27	2455.08			M I S F I R E			
28	2450.05	432	90	27	9	trace	trace
29	2445.09	491	34	18	9	trace	
30	2440.01	480	45	22	7	trace	

24141/25-26